

INSTALLATION MANUAL

CONTENTS

NOMENCLATURE	5
GENERAL	7
SAFETY CONSIDERATIONS	7
INSTALLATION	8
GAS HEATING	16
ELECTRICAL DATA	29
START-UP	74
GAS FURNACE OPERATING INSTRUCTIONS . . .	80
SERVICE	82
MAINTENANCE	100
START-UP SHEET	108

See the following pages for a complete Table of Contents.

NOTES, CAUTIONS AND WARNINGS

Installer should pay particular attention to the words: *NOTE*, *CAUTION*, and *WARNING*. Notes are intended to clarify or make the installation easier. Cautions are given to prevent equipment damage. Warnings are given to alert installer that personal injury and/or equipment damage may result if installation procedure is not handled properly.

CAUTION: READ ALL SAFETY GUIDES BEFORE YOU BEGIN TO INSTALL YOUR UNIT.

SAVE THIS MANUAL

MILLENNIUM™ ROOFTOP 25, 30 & 40 TON

MODELS: Z2
Z3
Z4



TABLE OF CONTENTS

NOMENCLATURE	5	SUPPLY AIR FAN INSTRUCTIONS	74
GENERAL	7	CHECK BLOWER BEARING SET SCREWS	74
SAFETY CONSIDERATIONS	7	CHECKING SUPPLY AIR CFM	74
NOTES, CAUTIONS AND WARNINGS	7	FAN ROTATION	74
GAS FIRED MODELS	7	BELT TENSION	74
WHAT TO DO IF YOU SMELL GAS	7	AIR BALANCE	74
ALL MODELS	7	CHECKING AIR QUANTITY	75
INSPECTION	7	SUPPLY AIR DRIVE ADJUSTMENT	76
REFERENCE	8	SYSTEM SETPOINTS	76
APPROVALS	8	CONSTANT VOLUME AND VARIABLE AIR VOLUME:	76
INSTALLATION	8	GAS FURNACE OPERATING	
PRECEDING INSTALLATION	8	INSTRUCTIONS	79
LIMITATIONS	8	TO LIGHT THE MAIN BURNERS	79
LOCATION	8	TO SHUT DOWN	79
RIGGING AND HANDLING	12	POST-START CHECKLIST (GAS)	79
CLEARANCES	12	MANIFOLD GAS PRESSURE ADJUSTMENT	80
DUCTWORK	13	BURNER INSTRUCTIONS	80
AIR HOODS FOR FIXED OUTSIDE AIR		ADJUSTMENT OF TEMPERATURE RISE	80
(UNITS WITH MANUAL ECONOMIZER)	13	CHECKING GAS INPUT	80
AIR HOODS FOR ECONOMIZER	13	NATURAL GAS	80
AIR HOODS FOR EXHAUST AIR	13	ELECTRIC HEATING	81
CONDENSATE DRAIN	13	COOLING OPERATING INSTRUCTIONS	81
SERVICE ACCESS	14	COMPRESSOR	81
COMPRESSORS	14	INTERNAL WIRING	81
FILTERS	14	CONDENSER FANS	81
THERMOSTAT (CONSTANT VOLUME UNITS)	14	SERVICE	81
SPACE SENSOR (VARIABLE AIR VOLUME UNITS)	15	REFRIGERATION SYSTEM	81
POWER AND CONTROL WIRING	15	COMPRESSORS	81
POWER WIRING DETAIL	15	MOTORS	81
ERV	15	INDOOR BLOWER MOTORS	81
GAS HEATING	16	POWER EXHAUST OR RETURN AIR FAN MOTORS	82
GAS PIPING	16	CONDENSER FAN MOTORS	82
GAS CONNECTION	16	DRAFT MOTOR (GAS FURNACE)	82
VENT AND COMBUSTION AIR	17	GAS FURNACE SAFETY FEATURES	99
ELECTRIC HEAT	20	COMBUSTION AIR PROVING	99
HOT WATER HEAT	20	ROLLOUT	99
PIPING CONNECTIONS	20	MAINTENANCE	99
STEAM HEAT	21	NORMAL MAINTENANCE	99
PIPING CONNECTIONS	21	FILTERS	99
STATIC PRESSURE CONTROL PLASTIC TUBING	21	MOTORS	99
EXHAUST STATIC PRESSURE	22	FAN DRIVES	100
ELECTRICAL DATA	29	OUTDOOR COIL	100
CFM, STATIC PRESSURE, AND POWER - ALTITUDE		GAS BURNER	100
AND TEMPERATURE CORRECTIONS	59	TO CLEAN BURNERS	100
START-UP	74	COMBUSTION AIR DISCHARGE	100
COMPRESSOR ROTATION	74	CLEANING FLUE PASSAGES AND HEATING ELEMENTS	100
		SECURE OWNERS APPROVAL	101
		START-UP SHEET	107

LIST OF FIGURES

<u>Fig. #</u>	<u>Pg. #</u>	<u>Fig. #</u>	<u>Pg. #</u>
1	6	32	80
2	10	33	81
3	11	34	85
4	14	35	85
5	14	36	86
6	16	37	86
7	17	38	87
8	18	39	87
9	19	40	88
10	19	41	88
11	21	42	89
12	21	43	89
13	23	44	90
14	24	45	90
15	25	46	91
16	26	47	91
17	54	48	92
18	55	49	92
19	55	50	93
20	56	51	94
21	56	52	95
22	57	53	96
23	58	54	97
24	60	55	98
25	61	56	101
26	63	57	101
27	65	58	102
28	67	59	103
29	71	60	104
30	73	61	105
31	74	62	106
		63	113

LIST OF TABLES

<u>Tb. #</u>	<u>Pg. #</u>	<u>Tb. #</u>	<u>Pg. #</u>
1	COOLING & ELECTRICAL APPLICATION	38	FAN PERFORMANCE - 40 TON,
2	COOLING & ELEC. APP. LIMITATIONS	39	COMPONENT STATIC RESISTANCE,
3	STANDARD GAS HEATING CAPACITIES	40	SUPPLY FAN MOTOR AND DRIVE DATA
4	TEMPERATURE RISE	41	EXHAUST FAN DRIVE DATA
5	MINIMUM HEATING CFM	42	POWER EXHAUST - ONE FORWARD CURVED FAN 25 TON
6	MODULATING GAS HEATING CAPACITIES	43	POWER EXHAUST - TWO FORWARD CURVED FANS - 30 & 40 TON
7	MODULATING HEAT	44	BELT ADJUSTMENT
8	UNIT WEIGHTS	45	BLOWER SPEED RATE OF CHANGE
9	SUPPLY FAN MOTOR VFD WEIGHTS	46	25 TON DRIVE ADJUSTMENT FOR CONSTANT VOLUME & VAV UNITS CLASS 1 & 2 FC FAN
10	EXHAUST FAN MOTOR VFD WEIGHTS	47	30 TON DRIVE ADJUSTMENT FOR CONSTANT VOLUME & VAV UNITS CLASS 1 & 2 FC FAN
11	UNIT CORNERWEIGHT	48	40 TON DRIVE ADJUSTMENT FOR CONSTANT VOLUME & VAV UNITS CLASS 1 & 2 FC FAN
12	UNIT CENTER OF GRAVITY	49	25 TON DRIVE ADJUSTMENT FOR INTELLISPEED (DISCRETE FAN CONTROL)
13	CONTROL WIRE SIZES	50	30 TON DRIVE ADJUSTMENT FOR INTELLISPEED (DISCRETE FAN CONTROL)
14	PIPE SIZES	51	40 TON DRIVE ADJUSTMENT FOR INTELLISPEED (DISCRETE FAN CONTROL)
15	GENERAL PHYSICAL DATA	52	DRIVE ADJUSTMENT FOR POWER EXHAUST - 25 TON
16	REFRIGERANT FACTORY CHARGE R-410A	53	DRIVE ADJUSTMENT FOR POWER EXHAUST - 30 & 40 TON
17	ELECTRICAL DATA 25 TON 208/230 VOLT WITHOUT ERV	54	GAS RATE - CUBIC FEET PER HOUR
18	ELECTRICAL DATA 25 TON 230 VOLT WITH ERV	55	STEAM COIL (1 ROW, 25 & 30 TON)
19	ELECTRICAL DATA 25 TON 460 VOLT WITHOUT ERV	56	STEAM COIL (1 ROW, 40 TON)
20	ELECTRICAL DATA 25 TON 460 VOLT WITH ERV	57	STATIC RESISTANCE STEAM COIL (25 & 30 TON)
21	ELECTRICAL DATA 25 TON 575 VOLT WITHOUT ERV	58	STATIC RESISTANCE STEAM COIL (40 TON)
22	ELECTRICAL DATA 25 TON 575 VOLT WITH ERV	59	HOT WATER COIL (1 ROW 25 & 30 TON)
23	ELECTRICAL DATA 30 TON 208/230 VOLT WITHOUT ERV	60	HOT WATER COIL (1 ROW, 40 TON)
24	ELECTRICAL DATA 30 TON 208/230 VOLT WITH ERV	61	WATER PRESSURE DROP (1 ROW, 25 & 30 TON)
25	ELECTRICAL DATA 30 TON 460 VOLT WITHOUT ERV	62	WATER PRESSURE DROP (1 ROW, 40 TONS)
26	ELECTRICAL DATA 30 TON 460 VOLT WITH ERV	63	HOT WATER COIL (2 ROW, 25 & 30 TON)
27	ELECTRICAL DATA 30 TON 575 VOLT WITHOUT ERV	64	WATER PRESSURE DROP (2 ROW, 25 & 30 TON)
28	ELECTRICAL DATA 30 TON 575 VOLT WITH ERV	65	WATER PRESSURE DROP (2 ROW, 40 TON)
29	ELECTRICAL DATA 40 TON 208/230 VOLT WITHOUT ERV	66	STATIC RESISTANCE HOT WATER COIL (25 & 30 TON)
30	ELECTRICAL DATA 40 TON 230 VOLT WITH ERV	67	STATIC RESISTANCE HOT WATER COIL (40 TON)
31	ELECTRICAL DATA 40 TON 460 VOLT WITHOUT ERV	68	INDOOR BLOWER BEARING LUBRICATION SCHEDULE
32	ELECTRICAL DATA 40 TON 460 VOLT WITH ERV		
33	ELECTRICAL DATA 40 TON 575 VOLT WITHOUT ERV		
34	ELECTRICAL DATA 40 TON 575 VOLT WITH ERV		
35	ALTITUDE CORRECTION FACTORS		
36	FAN PERFORMANCE - 25 TON,		
37	FAN PERFORMANCE - 30 TON,		

NOMENCLATURE

Millennium™ Model Number Nomenclature 25-40 Ton Single Package

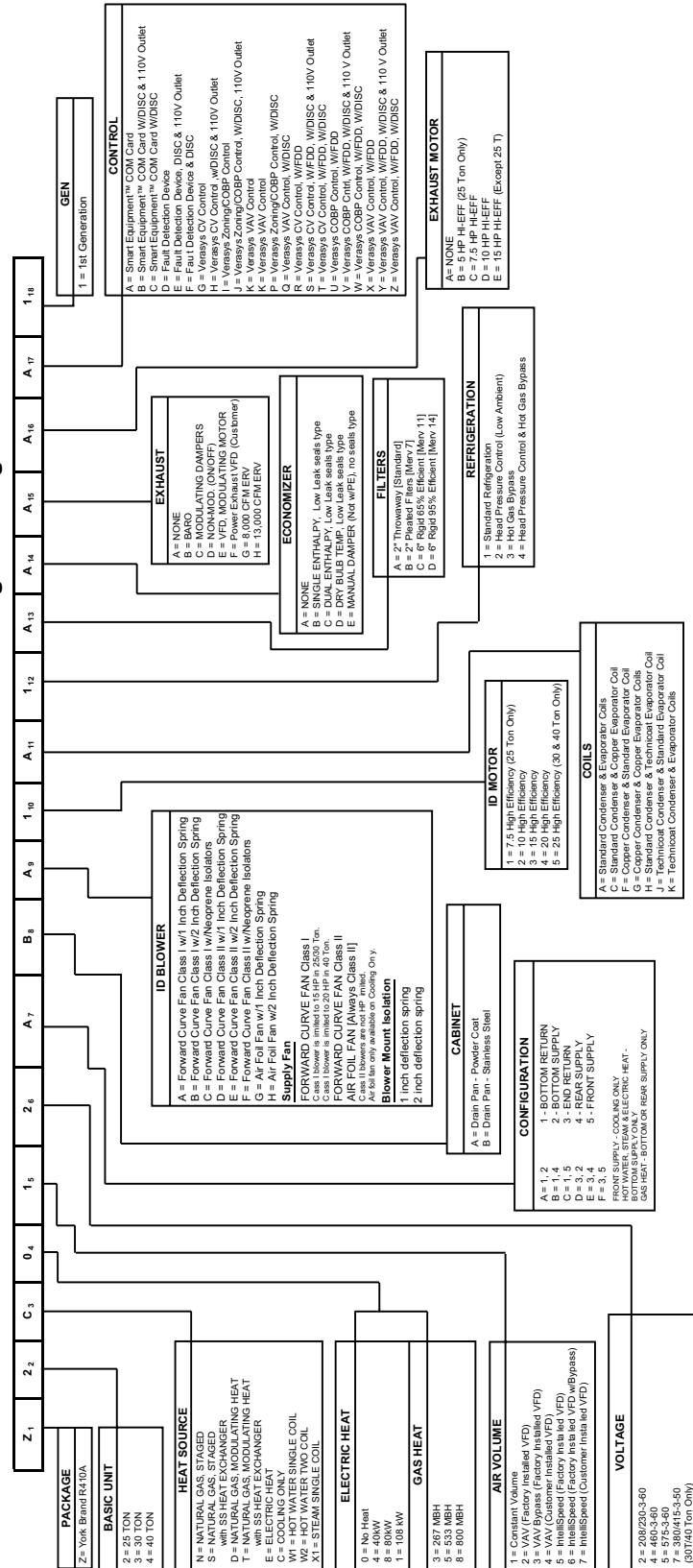

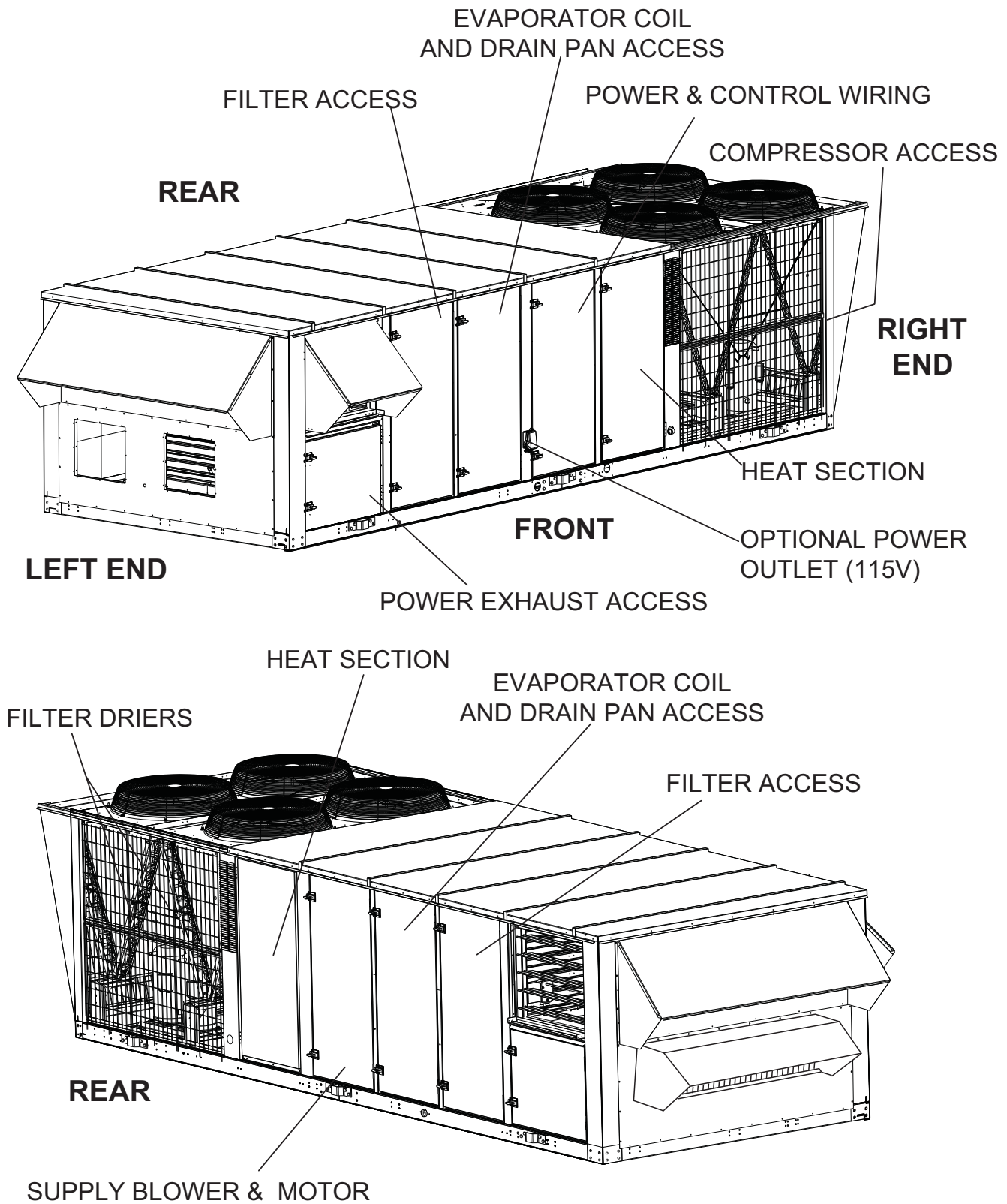

FIGURE 1 - COMPONENT LOCATION

GENERAL

York Model Z2/Z3/Z4 units are single package cooling only or cooling with gas, electric, hot water or steam heating designed for outdoor installation on a rooftop and for non-residential use.

The units are completely assembled on rigid, permanently attached base rails. All piping, refrigerant charge, and electrical wiring is factory installed and tested. The units require electric power, gas, steam, or hot water connections and duct connections. Gas fired units also require installation of a flue gas outlet hood.

Reference R-410A Quick Reference Guide, Figure 63 for R-410A Refrigerant information.

SAFETY CONSIDERATIONS

NOTES, CAUTIONS AND WARNINGS

Installer should pay particular attention to the words: *NOTE*, *CAUTION*, and *WARNING*. Notes are intended to clarify or make the installation easier. Cautions are given to prevent equipment damage. Warnings are given to alert installer that personal injury and/or equipment damage may result if installation procedure is not handled properly.

GAS FIRED MODELS

DO NOT store or use gasoline or other flammable vapors and liquids in the vicinity of this or any other appliance.

WHAT TO DO IF YOU SMELL GAS

Do not try to light any appliance. Do not touch any electrical switch. Do not use any phone in your building. Immediately call your gas supplier from a neighbor's phone. Follow the gas supplier's instructions. If you cannot reach your gas supplier, call the fire department.

CAUTION

The furnace and its individual shut-off valve must be disconnected from the gas supply piping system during any pressure testing of that system at test pressures in excess of 0.5 psig. Pressures greater than 0.5 will cause gas valve damage resulting in a hazardous condition. If gas valve is subjected to a pressure greater than 0.5 psig, it must be replaced. The furnace must be isolated from the gas supply piping system by closing its individual manual shut-off valve during any pressure testing of that system at test pressures equal to or less than 0.5 psig.

WARNING

This Furnace is not to be used for temporary heating of buildings or structures under construction.

ALL MODELS

CAUTION

This system uses R-410A Refrigerant which operates at higher pressures than R-22. No other refrigerant may be used in this system. Gage sets, hoses, refrigerant containers and recovery systems must be designed to handle R-410A. If you are unsure, consult the equipment manufacturer. Failure to use R-410A compatible servicing equipment may result in property damage or injury.

Installation and servicing of air conditioning equipment can be hazardous due to system pressure and electrical components. Only trained and qualified service personnel should install, repair or service air conditioning equipment.

Untrained personnel can perform basic maintenance functions of cleaning coils and filters and replacing filters. All other operations should be performed by trained service personnel. When working on air conditioning equipment, observe precautions in the literature, tags and labels attached to the unit and other safety precautions that may apply.

Follow all safety codes, including ANSI Z223.1-Latest Edition: wear safety glasses and work gloves; use quenching cloth for unbrazing operations; have fire extinguisher available for all brazing operations.

WARNING

Before performing service or maintenance operations on unit, turn off main power switch to unit. Electrical shock could cause personal injury.

Improper installation, adjustment, alteration, service or maintenance can cause injury or property damage. Refer to this manual. For assistance or additional information consult a qualified installer, service agency or the gas supplier.

INSPECTION

As soon as a unit is received, it should be inspected for possible damage during transit. If damage is evident, the extent of damage should be noted on the carrier's freight bill. A separate request for inspection by the carrier's agent should be made in writing.

REFERENCE

Additional information is available in the following reference form:

- 5276180 - Technical Guide

APPROVALS

Designed certified by CSA as follows:

1. For use as a forced air furnace with cooling unit (gas heat models).
2. For outdoor installation only.
3. For installation on combustible material and may be installed directly on combustible flooring or Class A, Class B or Class C roof covering materials.
4. For use with natural gas (convertible to LP with kit).

Not suitable for use with conventional venting systems.

INSTALLATION

PRECEDING INSTALLATION

If a factory option convenience outlet is installed, the weatherproof outlet cover must be field installed. The cover shall be located in the unit control box. To install the cover, remove the shipping label covering the convenience outlet, follow the instructions on the back of the weatherproof cover box, and attach the cover to the unit using the (4) screws provided.

CAUTION

208/230-3-60 and 380/415-3-50 units with factory installed Powered Convenience Outlet Option are wired for 230v and 415v power supply respectively. Change tap on transformer for 208-3-60 or 380-3-50 operation. See unit wiring diagram.

LIMITATIONS

The installation of this unit must conform to local building codes, or in the absence of local codes, with ANSI Z223.1 Natural Fuel Gas Code and /or CAN/CGA B149 installation codes.

In U.S.A.:

1. National Electrical Code ANSI/NFPA No. 70-Latest Edition.
2. National Fuel Gas Code Z223.1-Latest Edition.
3. Gas-Fired Central Furnace Standard ANSI Z21.47-Latest Edition.
4. Local gas utility requirements.

Refer to Table 1 for Cooling and Electrical Application Data and to Table 2 for Gas Heat Application Data.

After installation, gas fired units must be adjusted to obtain a temperature rise within the range specified on the unit rating plate.

If components are to be added to a unit to meet local codes, they are to be installed at the contractor's and/or the customer's expense.

Size of unit for proposed installation should be based on heat loss / heat gain calculation made according to the methods of the Air Conditioning Contractors of America (ACCA).

LOCATION

Use the following guidelines to select a suitable location for these units:

TABLE 1: COOLING & ELECTRICAL APPLICATION

UNIT POWER SUPPLY	VOLTAGE VARIATIONS	
	MIN. VOLTS	MAX VOLTS
575-3-60	540	630
208/230-3-60	187	252
460-3-60	432	504

TABLE 2: COOLING & ELEC. APP. LIMITATIONS

LIMITATIONS	MODEL		
	Z52	Z53	Z4
Supply Air CFM (min./max)	6,000-12,500	6,000-15,000	8,000-20,000
Entering Wet Bulb Temp (F°) (min./max)	57/75	57/75	57/75
Ambient Temp	40/125	40/125	40/125
Min. Air Temperature on Gas Fired Heat Exchangers (°F)			
Aluminized	25	25	25
Stainless	0	0	0

1. Unit is designed for outdoor installation only.
2. Condenser coils must have an unlimited supply of air. Where a choice of location is possible, position the unit on either north or east side of building.
3. Suitable for roof mount on curb.
4. Roof structures must be able to support the weight of the unit and its accessories. Unit must be installed on a solid level roof curb or appropriate angle iron frame.
5. Maintain level tolerance to 3/4 inches across width and 2 inches along length.

TABLE 3: STANDARD GAS HEATING CAPACITIES

GAS HEAT OPTION	AVAILABLE ON MODELS	INPUT CAPACITY (MBH) ¹		OUTPUT CAPACITY (MBH) ²	GAS RATE, CU. FT./HR. ³	
		1ST STAGE	TOTAL		1ST STAGE	TOTAL
N3	Z2/Z3/Z4	267	267	213	247	247
N5	Z2/Z3/Z4	267	533	426	247	495
N8	Z4 ONLY	267 ⁴	800	638	247	742

1. Heating capacity is only staged on CV models. VAV models use only one stage at full capacity.
2. Blower motor heat not included.
3. Based on a heat content of 1075 Btu/Ft.³

$$\text{GAS RATE} = \frac{\text{Input MBH}}{(1.075\text{MBH})/\text{Ft}}^3$$

4. Unit Control Board with 3 heating outputs only. For all other Unit Control Boards the 1st Stage is 533 MBH.

TABLE 4: TEMPERATURE RISE

TON	MODULES		
	1	2	3
25	5-35	25-55	-
30	5-35	20-50	-
40	5-30	10-45	25-55

TABLE 5: MINIMUM HEATING CFM

TON	MODULES		
	1 ¹	2	3
25	6,000	7,183	-
30	6,000	7,901	-
40	8,000	8,779	13,169

1. Calculated minimum CFM for maximum heat rise is 5,644 for 25/30T and 6,584 for 40T, 1 module.

TABLE 6: MODULATING GAS HEATING CAPACITIES

GAS HEAT OPTION	AVAILABLE ON MODELS	INPUT CAPACITY (MBH)		STEPS	OUTPUT CAPACITY (MBH) ¹	GAS RATE, CU. FT./HR.	
		MINIMUM	MAXIMUM			MINIMUM	MAXIMUM
D3 ²	Z2/Z3/Z4	69	267	6	213	64	247
D5 ²	Z2/Z3/Z4	69	533	12	426	64	495
D8 ²	Z4 ONLY	69	800	17	638	64	744

1. Output Capacity at Full Fire.
2. Modulating Gas Heat available on CV models only.

TABLE 7: MODULATING HEAT

STAGES OF GAS CONTROL (% OF FULL HEAT OUTPUT)					
GAS HEAT OPTION	AVAILABLE ON MODELS	STEP	INPUT	OUTPUT	% OF TOTAL OUTPUT
D3 (Turn down ratio 3.8 to 1)	Z2, Z3, Z4	1	69,333	55,466	26%
		2	106,666	85,333	40%
		3	165,332	132,266	62%
		4	202,665	162,132	76%
		5	229,332	183,466	86%
		6	266,666	213,333	100%
D5 (Turn down ratio 7.7 to 1)	Z2, Z3, Z4	1	69,333	55,466	13%
		2	106,666	85,333	20%
		3	165,332	132,266	31%
		4	202,665	162,132	38%
		5	229,332	183,466	43%
		6	266,666	213,333	50%
		7	325,331	260,265	61%
		8	362,664	290,132	68%
		9	389,331	311,465	73%
		10	426,664	341,331	80%
		11	495,997	396,798	93%
		12	533,330	426,664	100%
D8 (Turn down ratio 11.5 to 1)	Z4 Only	1	69,333	55,466	9%
		2	106,666	85,333	13%
		3	165,332	132,266	21%
		4	202,665	162,132	25%
		5	229,332	183,466	29%
		6	266,666	213,333	33%
		7	325,331	260,265	41%
		8	362,664	290,132	45%
		9	389,331	311,465	49%
		10	426,664	341,331	53%
		11	495,997	396,798	62%
		12	533,330	426,664	67%
		13	586,663	469,330	73%
		14	655,996	524,797	82%
		15	693,329	554,663	87%
		16	762,662	610,130	95%
		17	799,995	639,996	100%

CAUTION

If a unit is to be installed on a roof curb other than a York roof curb, gasketing must be applied to all surfaces that come in contact with the unit underside.

If a unit is to be installed on an angle iron frame it is recommended that it be sized to allow the bottom rail to overhang to facilitate installation of condensate drains (see Fig. 4).

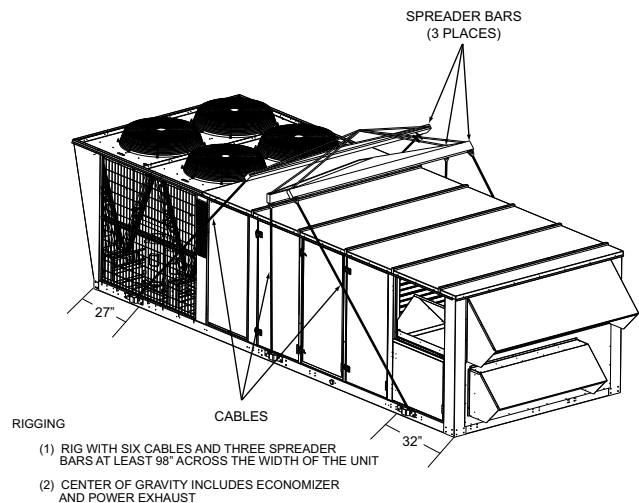

CAUTION
ALL PANELS MUST BE SECURED IN PLACE WHEN THE UNIT IS LIFTED

FIGURE 2 - TYPICAL RIGGING

TABLE 8: UNIT WEIGHTS

COMPONENT	25 TON	30 TON	40 TON
Basic Unit	4410	4605	4785
Gas Heat			
267 MBH	180	180	180
533 MBH	320	320	320
800 MBH	-	-	450
Electric Heat			
40KW	40	40	40
80KW	105	105	105
108KW	110	110	110
Hot Water Heat			
1 Row Coil	70	70	70
2 Row Coil	85	85	85
Steam Heat			
1 Row Coil	85	85	85
Blower			
Forward Curve Fan (Std Fan)	0	0	0
FC IGV	155	155	175
Air Foil Fan	135	135	155
AF IGV	155	155	180
Motor - Supply Fan			
7.5hp	110	-	-
10hp	145	145	145
15hp	200	200	200
20hp	240	240	240
25hp	-	300	300
Supply Fan Motor VFD	See Table 9		
Refrigeration			
T-Coat And E-Fin Evap.	32	30	40
T-Coat cond.	32	30	40
Hot Gas Bypass	10	10	10
Low Ambient Head Pressure Control			
208-230/380/460	5	5	5
575	25	25	25
Filters			
6" Rigid	70	70	70
Exhaust¹			
Exhaust Type			
Barometric	45	65	65
Modulated	140	275	275
Exhaust Motor			
5hp	80	80	80
7.5hp	110	110	110
10hp	145	145	145
15hp	200	200	200
Exhaust Motor VFD	See Table 10		
Economizer			
Std. Econ.	235	235	235
Econ. w/ERV	50	50	50
Control			
Disconnect	15	15	15
110V outlet	55	55	55
Optilogic	20	20	20
Roof Curb			
Partial Curb	415	415	415

¹ If ERV and Supply Fan VAV are selected, add the weight of an Exhaust VFD, Table 9.

TABLE 9: SUPPLY FAN MOTOR VFD WEIGHTS

Supply Fan Motor VFD	230V	460V	575V
W/O Bypass			
7.5hp	60	25	30
10hp	60	25	30
15hp	75	50	60
20hp	75	50	60
25hp	115	50	60
W/Bypass			
7.5hp	155	90	120
10hp	155	90	120
15hp	185	140	155
20hp	185	140	155
25hp	255	140	155

TABLE 10: EXHAUST FAN MOTOR VFD WEIGHTS

Exhaust Fan Motor	230V	460V	575V
W/O Bypass			
5hp	15	10	20
7.5hp	50	15	20
10hp	50	15	20
15hp	65	40	50

NOTE: If the Millennium is VAV with ERV, add the weight of an exhaust VFD - it will be in the unit.

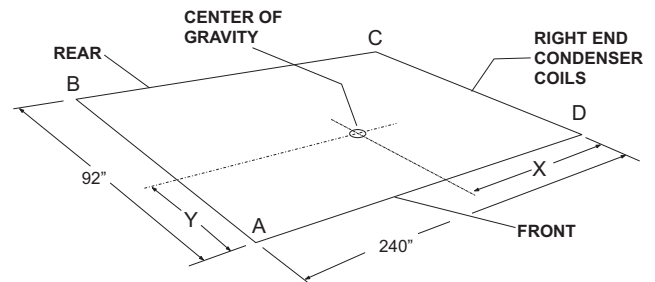

FIGURE 3 - CENTER OF GRAVITY¹

¹ Refer to Tables 11 and 12 for A, B, C, D and X and Y data respectively.



All panels must be secured in place when the unit is lifted.

The condenser coils should be protected from damage by the rigging cables with plywood or other suitable material.

An adhesive backed cover is provided over the outside of the combustion air inlet opening on gas fired units to prevent moisture from entering the unit which could cause damage to electrical components. Allow this closure label to remain in place until the combustion air hood is to be installed (Refer to Figure 7).

RIGGING AND HANDLING

This unit is *not* designed to be handled with a fork-truck.

Exercise care when moving the unit. Do not remove any packaging until the unit is near the place of installation. Rig the unit by attaching cable slings to the lifting lugs provided in the unit base rails. Spreaders **MUST** be used across the top of the unit. Refer to Figure 2.

- Rig with six cables and spread with three 98-inch spreaders across width of unit.
- Refer to Tables 8 and 11 for unit weight.
- Center of gravity includes economizer, exhaust or return air fan (Refer to Table 12).

TABLE 11: UNIT CORNERWEIGHT

UNIT DISCRPTION	25 TON				30 TON				40 TON			
	A	B	C	D	A	B	C	D	A	B	C	D
BASIC UNIT	870	949	1352	1239	932	932	1369	1369	975	975	1418	1418
BASIC UNIT /W ECON.	1018	1111	1313	1203	1078	1084	1337	1338	1064	1064	1446	1446
BASIC UNIT /W ECON & GAS OR ELECT. HEAT, STEAM OR HOT WATER HEAT	994	1084	1418	1300	1075	1033	1412	1469	1108	1061	1467	1534
BASIC UNIT /W ECON. & GAS OR ELECT. HEAT, & POWER EXHAUST	1220	1275	1318	1262	1277	1235	1419	1476	1341	1284	1449	1515

NOTES: Basic Unit = cooling only, 10hp FC fan.
 + Econ = +235lb
 + Heat = single stage gas, 180 lb
 + Power Exhaust = modulating 7.5hp

TABLE 12: UNIT CENTER OF GRAVITY

MODEL	25 TON		30 TON		40 TON	
	X	Y	X	Y	X	Y
BASIC UNIT	99	48	97	46	98	46
BASIC UNIT /W ECON.	110	48	107	46	102	46
BASIC UNIT /2 ECON & GAS OR ELECT. HEAT, STEAM OR HOT WATER HEAT	104	48	101	47	101	47
BASIC UNIT /W ECON. & GAS OR ELECT. HEAT, & POWER EXHAUST	118	47	111	47	113	47

CLEARANCES

All units require certain clearances for proper operation and service. Installer must make provisions for adequate combustion and ventilation air in accordance with section 5.3, Air for Combustion and Ventilation of the National Fuel Gas Code ANSI Z223.1 or Sections 7.2, 7.3 or 7.4 of CAN/CGA B149 installation codes-Latest Edition and/or applicable provisions of the local building codes. Refer to Figure 9 for clearances required for combustible construction, servicing, and proper unit operation.



(COOLING OPERATION) Do not permit overhanging structures or shrubs to obstruct condenser air discharge outlet, combustion air inlet or vent outlets.

▲ WARNING

(GAS HEATING OPERATION)

Excessive exposure to contaminated combustion air will result in safety and performance related problems. To maintain combustion air quality, the recommended source of combustion air is the outdoor air supply.

The outdoor air supplied for combustion should be free from contaminants due to chemical exposure that may be present from the following sources:

- Commercial buildings
- Indoor pools
- Laundry rooms
- Hobby or craft rooms
- Chemical storage areas

The following substances should be avoided to maintain outdoor combustion air quality:

- Permanent wave solutions
- Chlorinated waxes and cleaners
- Chlorine based swimming pool cleaners
- Water softening chemicals
- De-icing salts or chemicals
- Carbon tetrachloride
- Halogen type refrigerants
- Cleaning solvents (such as perchloroethylene)
- Printing inks, paint removers, varnishes, etc.
- Hydrochloric acid
- Cements and glues
- Antistatic fabric softeners for clothes dryers
- Masonry acid washing materials

DUCTWORK

Ductwork should be designed and sized according to the methods in Manual Q of the Air Conditioning Contractors of America (ACCA).

A closed return duct system should be used. This will not preclude use of economizers or outdoor fresh air intake. The supply and return air duct connections at the unit should be made with flexible joints to minimize noise.

When the unit is equipped with power exhaust fans or return air fan the return duct should have a 90 elbow before opening to the building space to abate noise.

The supply and return air duct systems should be designed for the CFM and static pressure requirements of the job. They should NOT be sized to match the dimensions of the duct connections on the unit.

If the unit is equipped with hot water or steam heat then the supply air direction will be down only.

AIR HOODS FOR FIXED OUTSIDE AIR (UNITS WITH MANUAL ECONOMIZER)

These hoods are factory installed. The dampers may be adjusted by loosening the thumb screw, turning the lever to the desired position, and retightening the thumb screw.

AIR HOODS FOR ECONOMIZER

There are (3) economizer outside air intake hoods provided with the unit. The hood on the end of the unit is factory mounted. The (2) front and rear hoods are made operational per the following instructions.

Remove the screws holding the economizer hood shipping covers in place. Discard covers.

Rotate the hoods out (each hood is hinged in the lower corner). Secure the hoods with screws along the top and sides.

Apply a bead of RTV sealer along the edge of both hoods and each pivot joint to prevent water leakage.

Seal any unused screw holes with RTV or by replacing the screw.

AIR HOODS FOR EXHAUST AIR

When furnished, these hoods and dampers are factory installed.

CONDENSATE DRAIN

There is one condensate drain connection. Trap the connection per Figure 4. The trap and drain lines should be protected from freezing.

Plumbing must conform to local codes. Use a sealing compound on male pipe threads. Install condensate drain lines from the 1-1/2 inch NPT female connections on the unit to an open drain.

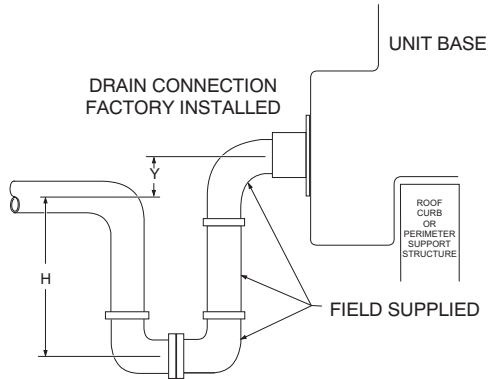

Y - MINIMUM 2"
 H - 1/2" PLUS TOTAL STATIC PRESSURE - MINIMUM

FIGURE 4 - RECOMMENDED DRAIN PIPING

SERVICE ACCESS

Access to all serviceable components is provided by the following hinged doors:

- Furnace compartment
- Supply Air Fan compartment Evaporator Coil compartment (three doors)
- Filter compartment economizer compartment (two doors)
- Power Exhaust compartment (two doors)
- Main control panels (one door)

Refer to Figure 1 for location of these access panels.

⚠ CAUTION

Make sure that all screws and panel latches are replaced and properly positioned on the unit to maintain an air-tight seal.

COMPRESSORS

Units are shipped with compressor mountings factory-adjusted and ready for operation.

⚠ CAUTION

DO NOT loosen compressor mounting bolts.

FILTERS

Throwaway or rigid filters are supplied with each unit. Filters must always be installed ahead of evaporator coil and must be kept clean or replaced with same size and type. Dirty filters will reduce the capacity of the unit and will result in frosted coils or safety shutdown. Required filter sizes are shown in Table 15. The unit should not be operated without filters properly installed.

THERMOSTAT (CONSTANT VOLUME UNITS)

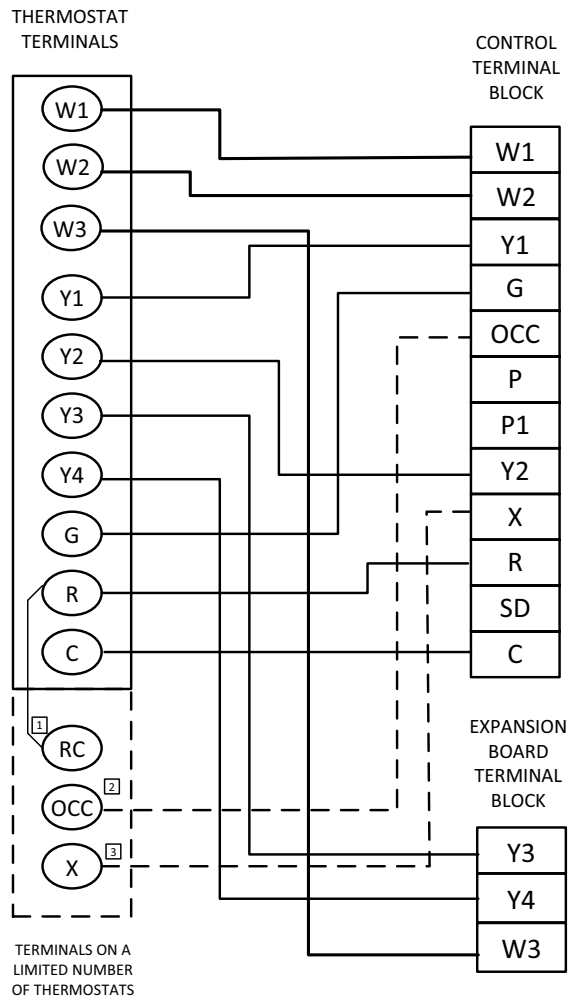

- 1 Jumper is required for any combination of R, RC, or RH.
- 2 OCC is an output from the thermostat to indicate the Occupied condition.
- 3 X is an input to the thermostat to display Error Status conditions.

FIGURE 5 - TYPICAL THERMOSTAT WIRING

The thermostat, if used, should be located on an inside wall approximately 56 inches above the floor where it will not be

subject to drafts, sun exposure or heat from electrical fixtures or appliances. Follow manufacturer's instructions enclosed with sensor for general installation procedure (See Figure 5). Refer to Table 13 for control wire sizing and maximum length.

TABLE 13: CONTROL WIRE SIZES

WIRE SIZE	MAXIMUM LENGTH
20 AWG	100 Feet
18 AWG	150 Feet

SPACE SENSOR (VARIABLE AIR VOLUME UNITS)

The space sensor, if used, should be located on an inside wall approximately 56 inch above the floor where it will not be subject to drafts, sun exposure or heat from electrical fixtures or appliances. Follow manufacturer's instructions enclosed with sensor for general installation procedure.

POWER AND CONTROL WIRING

Field wiring to the unit must conform to provisions of National Electrical Code (NEC) ANSI / NFPA 70-Latest Edition and / or local ordinances. The unit must be electrically grounded in accordance with the NEC and / or local codes. Voltage tolerances which must be maintained at the compressor terminals during starting and running conditions are indicated on the unit Rating Plate and Table 1.

The internal wiring harnesses furnished with this unit are an integral part of the design certified unit. Field alteration to comply with electrical codes should not be required. If any of the wire supplied with the unit must be replaced, replacement wire must be of the type shown on the wiring diagram and the same minimum gauge as the replaced wire.

Power supply to the unit must be NEC Class 1 and must comply with all applicable codes. A disconnect switch must be provided (factory option available). The switch must be separate from all other circuits. Wire entry at knockout openings requires conduit fittings to comply with NEC and/or Local Codes. Refer to Figures 13, 14, 15, and 16 for installation location of openings.

If installing a field mounted disconnect on the unit, refer to Figure 17 for the recommended mounting location. Unitstrut™ or equivalent rails should be mounted as shown to provide structure for mounting. The location of the rails should be adjusted to fit the disconnect within the dimensions shown. Conduit run from the disconnect to the power entry

location in the baserail should be routed so that it does not interfere with the doors of the unit access panels.

CAUTION

Use care to avoid damage when drilling holes for the disconnect mounting.

NOTE: Since not all local codes allow mounting a disconnect on the unit, please confirm compliance with local code before mounting a disconnect on the unit.

Electrical wiring must be sized properly to carry the load. Each unit must be wired with a separate branch circuit fed directly from the meter panel and properly fused.

CAUTION

When connecting electrical power and control wiring to the unit, waterproof connectors **MUST BE USED** so that water or moisture cannot be drawn into the unit during normal operation. The above waterproofing conditions will also apply when installing a field-supplied disconnect switch.

Refer to Figure 5 for typical field wiring and to the appropriate unit wiring diagram mounted inside control doors for control circuit and power wiring information.

POWER WIRING DETAIL

Units are factory wired for the voltage shown on the unit nameplate. The main power block requires copper wires. Refer to Electrical Data Tables 17 through 34 to size power wiring, fuses and disconnect switch. All field supplied wiring, fuses and disconnects must comply with applicable NEC codes.

Power wiring is brought into the unit through the side of the baserail or the bottom of the unit/control box inside the curb. The baserail has a 2-1/2" diameter hole for field wiring and a 3-5/8" hole is provided for a through-the-curb connection. A removable patch plate covers both the openings.

CAUTION

Waterproof connections **MUST** be used to ensure that water cannot penetrate the roof or roof curb.

ERV

The ERV [Energy Recovery Ventilation] is a separate air handler that attaches to the exhaust end of the 25-40T Millen-

nium packaged rooftop unit. The ERV is shipped separately and assembled to the Millennium at the job site. An 'ERV' Millennium is shipped with an end configuration and electric hookups designed to mate with the ERV. This option is available only with the Smart Equipment™ control, and no other power exhaust option can be supplied if an ERV is selected.

The ERV incorporates a rotating heat exchange wheel and a pair of exhaust blowers. It exhausts return air through the wheel, capturing the thermal energy of the exiting hot or cold air as it passes. As the wheel rotates, the incoming air stream, pulled through by the supply fan, regains that energy.

The Millennium ERV has a terminal block and mating connectors to simplify hooking up the two systems. The controls of both units are factory set to interact properly. Power for the ERV blower motors and controls is provided through the Millennium unit. The Millennium /ERV data plate information includes the ERV electrical load.

The Millennium Smart Equipment™ control has parameters for the ERV; refer to the parameter list. When economizer and ERV options are selected on the same unit, the Smart Equipment™ control and the ERV have specific connections and internal rules for that operation.

Also refer to the ERV Installation Instructions packaged with the ERV.

GAS HEATING

 WARNING
<p>On VAV units with gas fired furnace, ALL INDIVIDUAL ROOM DAMPER BOXES MUST BE CONTROLLED FULL OPEN DURING HEATING OPERATION TO ENSURE PROPER AIRFLOW OVER THE FURNACE. A control contact powered by the "VAV OPEN" terminals on the Smart Equipment™ control is provided for the damper box interlock. this contact is normally open, and is closed during heating operation.</p>

GAS PIPING

Proper sizing of gas piping depends on the cubic feet per hour of gas flow required, specific gravity of the gas and the length of run. National Fuel Gas Code Z223.1-Latest Edition should be followed in all cases unless superseded by local codes or gas company requirements. Refer to Table 14.

The heating value of the gas may differ with locality. The value should be checked with the local gas utility.

TABLE 14: PIPE SIZES

LENGTH IN FEET	NOMINAL IRON PIPE, SIZE		
	1-1/4 IN. ¹	1-1/2 IN. ¹	2 IN. ¹
10	1,050	1,600	3,050
20	730	1,100	2,100
30	590	890	1,650
40	-	760	1,450
50	-	-	1,270
60	-	-	1,150
70	-	-	1,050
80	-	-	990

1. Maximum capacity of pipe in cubic feet of gas per hour (based upon a pressure drop of 0.3 inch water column and 0.6 specific gravity gas.

NOTE: There may be a local gas utility requirement specifying a minimum diameter for gas piping. All units require a 1-1/4 inch pipe connection at the entrance fitting. Line should not be sized smaller than the entrance fitting size.

GAS CONNECTION

The gas supply line should be routed within the space and penetrate the roof at the gas inlet connection of the unit. Refer to Figures 13 through 16 to locate the access opening. Typical supply piping arrangements are shown in Figure 6.

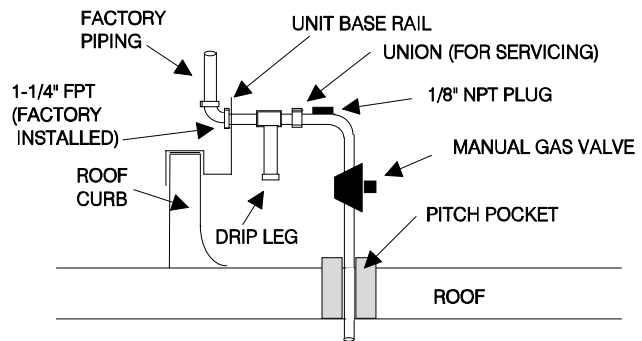

FIGURE 6 - TYPICAL GAS PIPING CONNECTION

Gas piping recommendations:

1. A drip leg and a ground joint union must be installed in the gas piping.
2. When required by local codes, a manual shut-off valve will have to be installed outside of the unit.
3. Use wrought iron or steel pipe for all gas lines. Pipe dope should be applied sparingly to male threads only.

⚠ WARNING

Natural gas may contain some propane. Propane, is an excellent solvent and will quickly dissolve white lead or most standard commercial pipe sealing compounds. Therefore, special shellac base pipe dope compounds such as Gaskolac or Stalastic, and compounds such as Rectorseal #5, Clyde's or John Crane must be applied for wrought iron or steel pipe.

4. All piping should be cleaned of dirt and scale by hammering on the outside of the pipe and blowing out the loose particles. Before initial start-up, be sure that all of the gas lines external to the unit have been purged of air.
5. The gas supply should be a separate line and installed in accordance with all safety codes as prescribed under Limitations. After the gas connections have been completed, open the main shutoff valve admitting normal gas pressure to the mains. Check all joints for leaks with soap solution or other material suitable for the purpose. NEVER USE A FLAME.
6. The furnace and its individual manual shut-off valve must be disconnected from the gas supply piping system during any pressure testing of that system at test pressures in excess of 0.5 psig.

⚠ CAUTION

Disconnect gas piping from unit when leak testing at pressures greater than 0.5 psig. Pressures greater than 0.5 psig will cause gas valve damage resulting in a hazardous condition. If gas valve is subjected to pressure greater than 0.5 psig, it must be replaced.

7. A 1/8 inch N.P.T. plugged tapping, accessible for test gage connection, must be installed immediately upstream of the gas supply connection to the furnace.

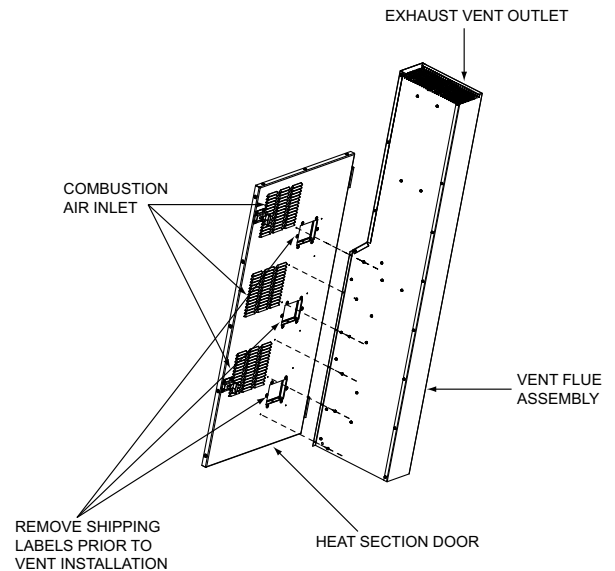
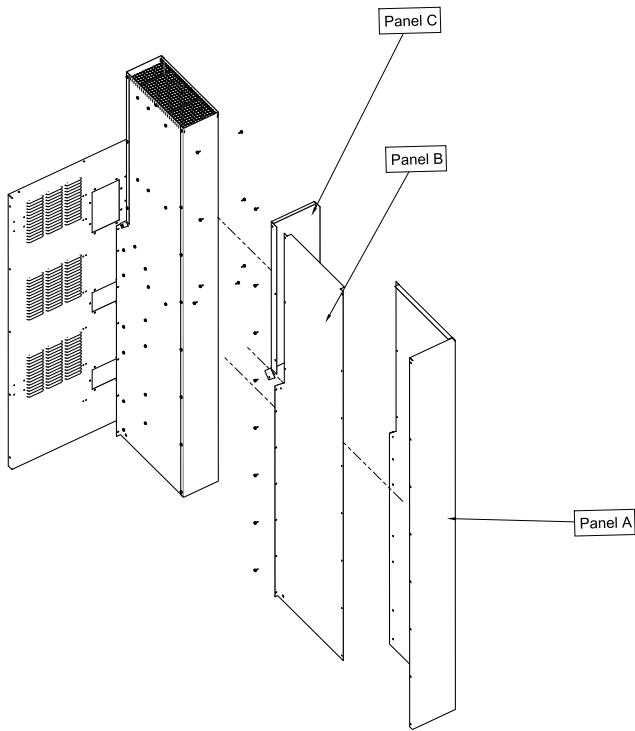

FIGURE 7 - VENT AND COMBUSTION AIR HOODS

VENT AND COMBUSTION AIR

NOTE: All the hoods and hardware are shipped within the evaporator section. Each hood must be properly attached to the furnace doors to assure proper operation and compliance with CSA/ETL safety certification. (Refer to Figure 7.)

The products of combustion are discharged horizontally through hooded openings in the gas heat access doors.



2. Locate the flue which is shipped in the evaporator section.
3. Place the flue over the flue outlet and attach with screws provided.
4. Refer to the Gas Furnace Operation Instruction in the Start-up Section of this manual for further instructions.

NOTE: (FOR MODULATING GAS HEAT ONLY) Locate the flue hood and shell which is shipped in the Evaporator section Referencing figure 8 place the shell over the flue and attach with screws provided.

Figure 8: MODULATING GAS HEAT FLUE HOOD

1. Remove the shipping covers that are attached to the heat section door covering the flue outlets.

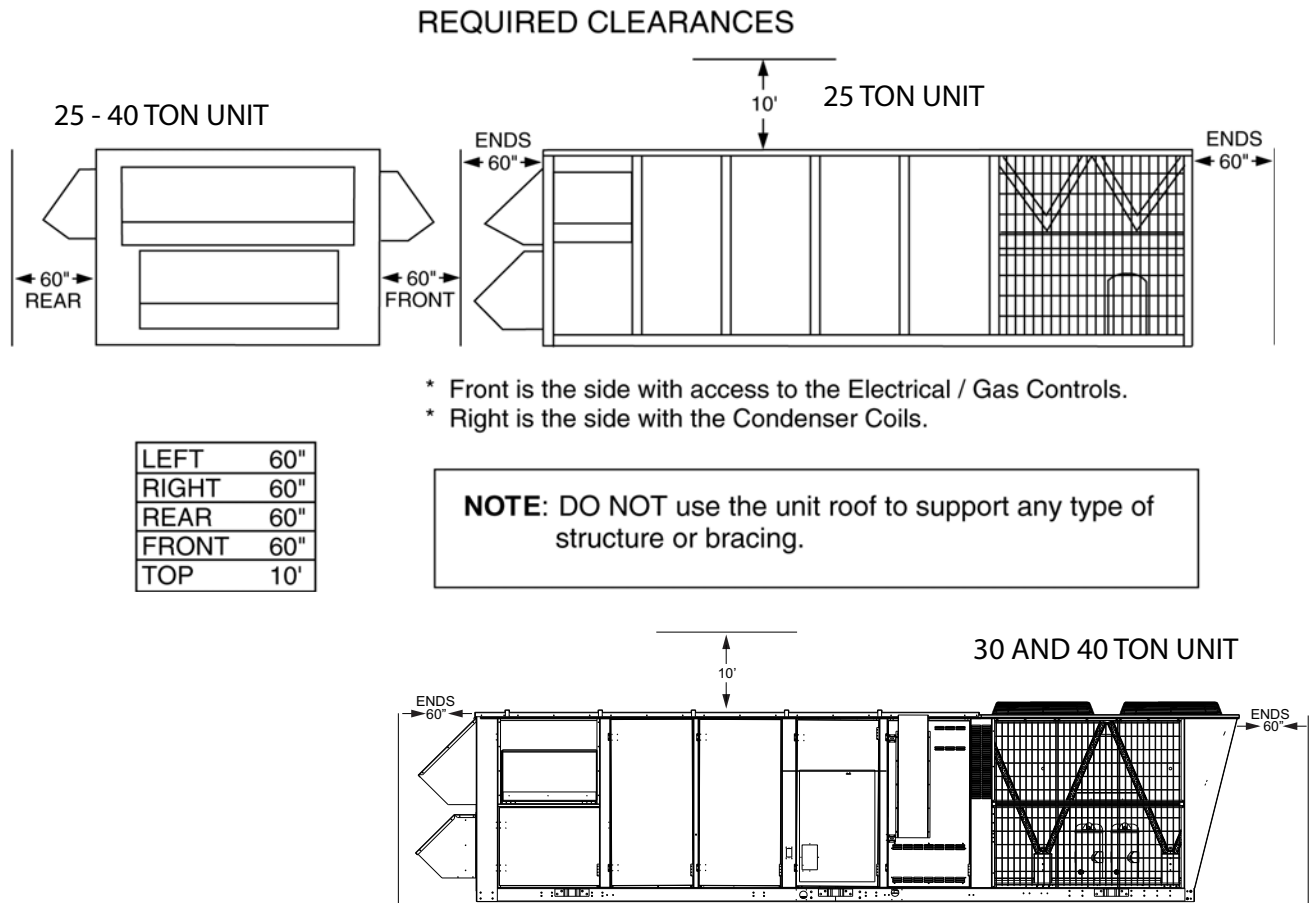

FIGURE 9 - CLEARANCES

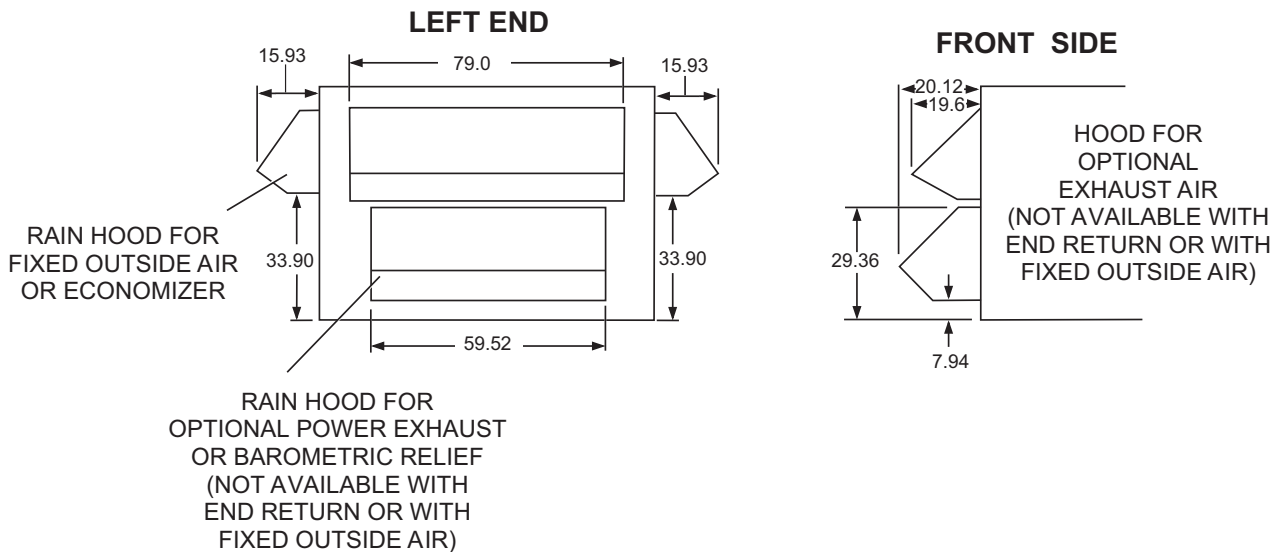

FIGURE 10 - CLEARANCES - HOOD/ECONOMIZER & MOTOR DRIVE - FRONT & END

ELECTRIC HEAT

Units with electric heat are fully wired and operational when shipped. Constant volume units are designed for two equal steps of capacity for 80 and three for 108 kWh heat; 40 kW heat is one step only. Heat outputs on VAV units are all turned on together at full heat capacity.

HOT WATER HEAT

The YORK Millennium units (25, 30, and 40 Ton sizes) can be furnished with a YORK hot water coil as the heat source. One or two row coil units will be factory installed in the heating section.

NOTE: The hot water control valve will not be provided. The installer will need to provide a hot water control valve, to connect the hot water piping and power wiring at the job site for the hot water heat section to be operational.

CAUTION

DO NOT use hot water coils as steam coils under any circumstances.

All piping, control valves, and wiring that is field installed must be properly insulated and conform to all local and national codes.

NOTE: For all hot water coils the entering water temperature should not exceed 200°F.

The hot water coil is located downstream of the supply air fan and just above the supply air opening in the bottom of the unit.

Refer to Tables 59 through 67 and Figures 34 through 47 for flow rate and capacity.

CAUTION

There are no provisions in the coil or control sequence to prevent freezing of condensate. The control valve, piping and field installed wiring connections are particularly vulnerable because they are installed in the vestibule outside of the conditioned air stream. The installing party will be responsible for properly insulating and installing power and control wiring, to the actuator and piping.

In one row hot water coil systems DO NOT exceed a 40 gallons per minute flow rate.

In two row hot water coil systems DO NOT exceed an 80 gallons per minute flow rate.

Condensate will freeze on the control valve and piping if they are not properly insulated. Insulating the control valve and piping is the responsibility of the installing party.

PIPING CONNECTIONS

The hot water piping must enter the unit through the floor of the heat section compartment. The access doors to the compartment are gasketed so the compartment can be sealed. However, as added protection for water leakage into the space, the piping access holes should be sealed with a heat resistant mastic Figure 11 shows the location of the compartment and piping connections.

CAUTION

Piping access holes should be sealed with a heat resistant mastic to prevent damage to equipment.

⚠ WARNING

DO NOT use tin based solder. Brazing with tin based solder could cause equipment damage or possible injury to tenants of the structure that is being conditioned.

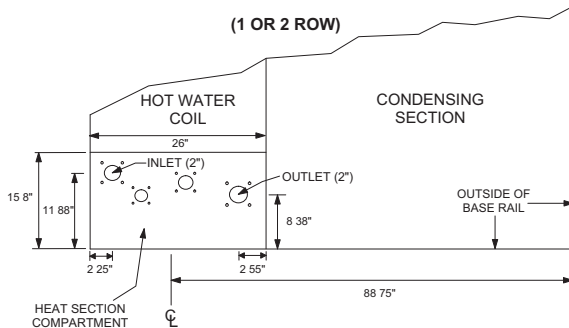

FIGURE 11 - HOT WATER PIPING CROSS-SECTION

STEAM HEAT

The YORK Millennium units (25, 30 and 40 Ton sizes) can be furnished with a YORK single row steam coil. YORK steam coils are a factory installed option.

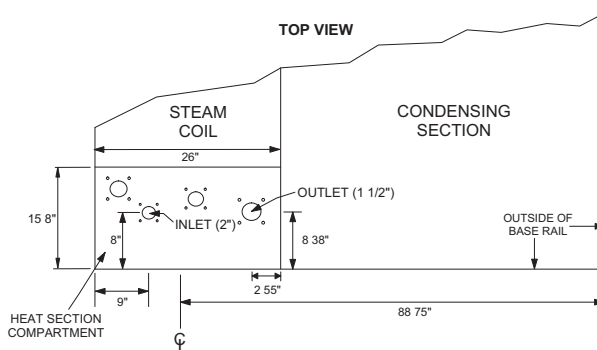

FIGURE 12 - STEAM PIPING CROSS-SECTION

NOTE: The steam control valve, power and control wiring to the actuator of the valve is the responsibility of the installing party.

⚠ CAUTION

All piping and control valves, and wiring that is field installed must be properly insulated and conform to all local and national codes.

There are no provisions in the coil or control sequence to prevent freezing of condensate. The control valve, piping and field installed wiring connections are particularly vulnerable because they are installed in the vestibule outside of the conditioned air stream. The installing party will be responsible for properly insulating and installing power and control wiring, to the actuator and piping.

DO NOT use steam coils as hot water coils under any circumstances.

In steam coil systems, the steam pressure shall not exceed 15 PSI.

PIPING CONNECTIONS

Refer to Tables 55 through 58 and Figures 48 and 49 for flow rate and capacity.

The steam piping must enter the unit through the floor of the heat section compartment. The access doors to the compartment are gasketed so the compartment can be sealed. However, as added protection for condensate leakage into the space, the piping access holes should be sealed with a heat resistant mastic. The following figure illustrates the location of the compartment and piping connections.

⚠ CAUTION

Piping access holes should be sealed with a heat resistant mastic to prevent damage to equipment.

⚠ WARNING

DO NOT use tin based solder. Brazing with tin based solder could cause equipment damage or possible injury to tenants of the structure that is being conditioned.

STATIC PRESSURE CONTROL PLASTIC TUBING

On units with variable frequency drives (VFD's) or inlet guide vanes (IGV's) on the supply blower and/or power exhaust

fans, pressure sensing tubing must be field supplied and installed. All tubing must be installed from the transducers (located in the unit) to the location in the building (or ductwork) where a constant pressure is desired. The tubing must also be installed from the transducers to a low-side reference to the atmosphere.

The supply air duct pressure sensor (DPS) is located in the control box directly below the Millennium Smart Equipment™ control. Plastic tubing (1/4") must be run from the high pressure tap of the transducer to a static pressure tap (field supplied) in the supply duct located at a point where constant pressure is desired. Tubing must also be run between the low pressure tap of the transducer to atmospheric pressure. Changing the adjustment is done to the duct pressure set-point in the control.

EXHAUST STATIC PRESSURE

If a modulating-damper or variable frequency drive power exhaust is installed, there will be a building pressure sensor

(BPS) in the control box directly below the Millennium Smart Equipment™ control. This $\pm .25$ 0-5VDC transducer sends a building pressure signal to the control. A sensing tube must be installed from a representative location in the building to the HI port of the transducer. Tubing must also be run between the low pressure tap of the transducer to atmospheric pressure.

Changing the adjustment is done to the building pressure set-point in the control.

 CAUTION
Do not run plastic tubes in the supply or return air ducts as air movement could cause erroneous sensing. If tubes penetrate bottom of unit be sure openings are sealed against air and water leakage.

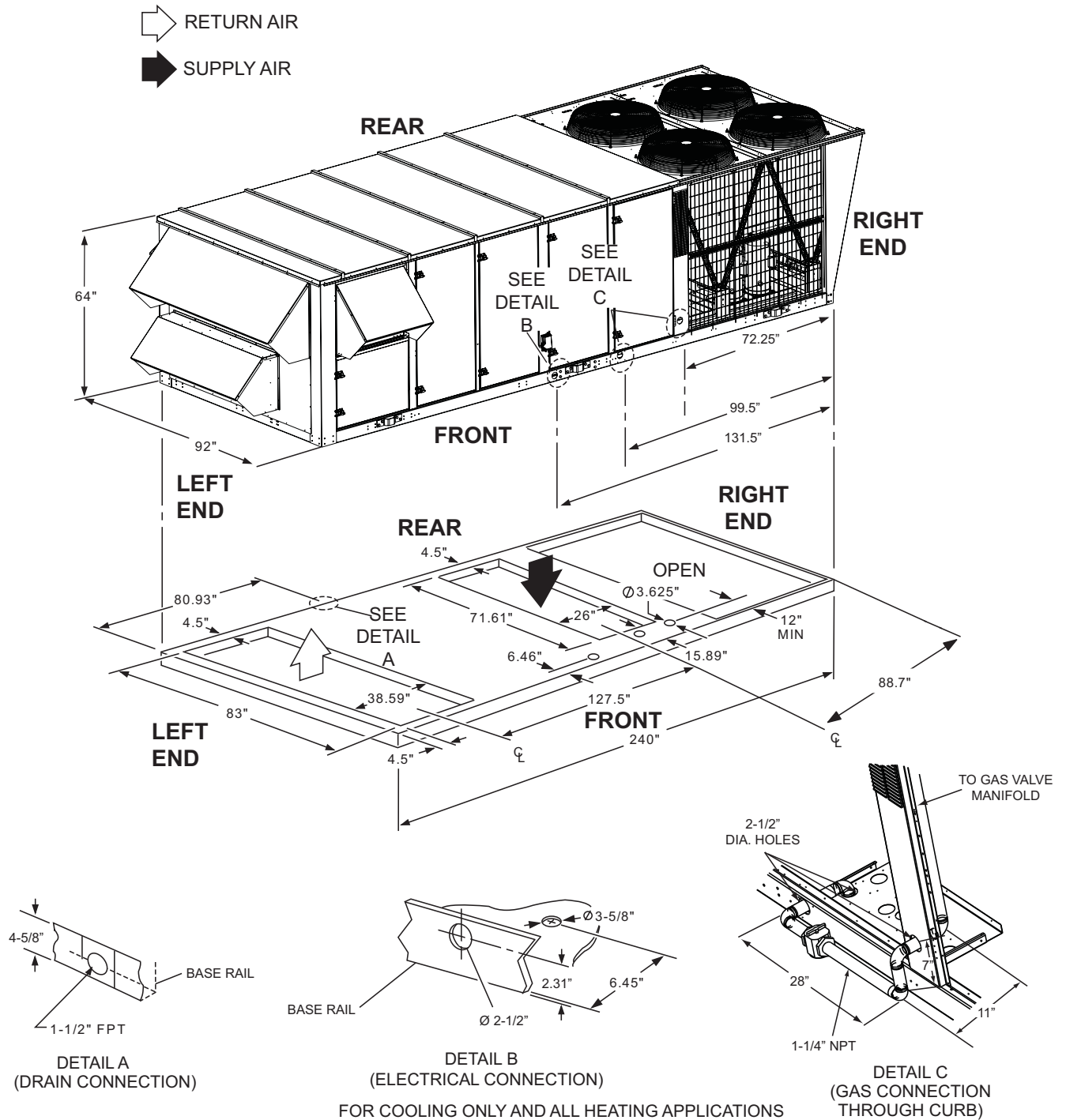
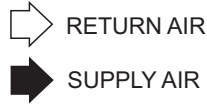

FIGURE 13 - BOTTOM SUPPLY AND RETURN



NOTE:
FACTORY INSTALLED POWER
EXHAUST CANNOT BE ORDERED
WITH END RETURN.

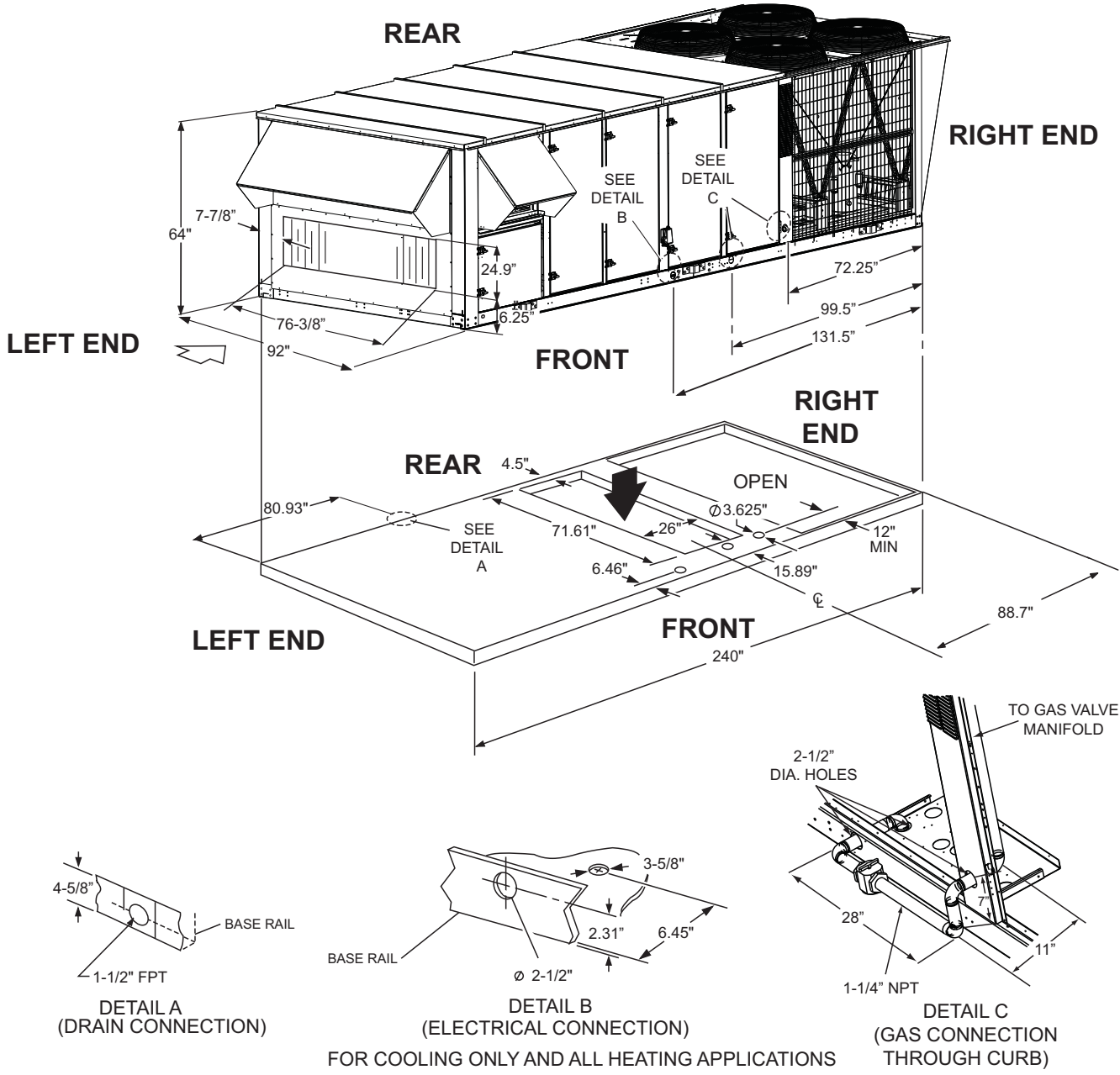

FIGURE 14 - END RETURN, BOTTOM SUPPLY

FRONT SUPPLY: FOR COOLING ONLY APPLICATIONS
 REAR SUPPLY: FOR COOLING ONLY OR GAS HEAT APPLICATIONS

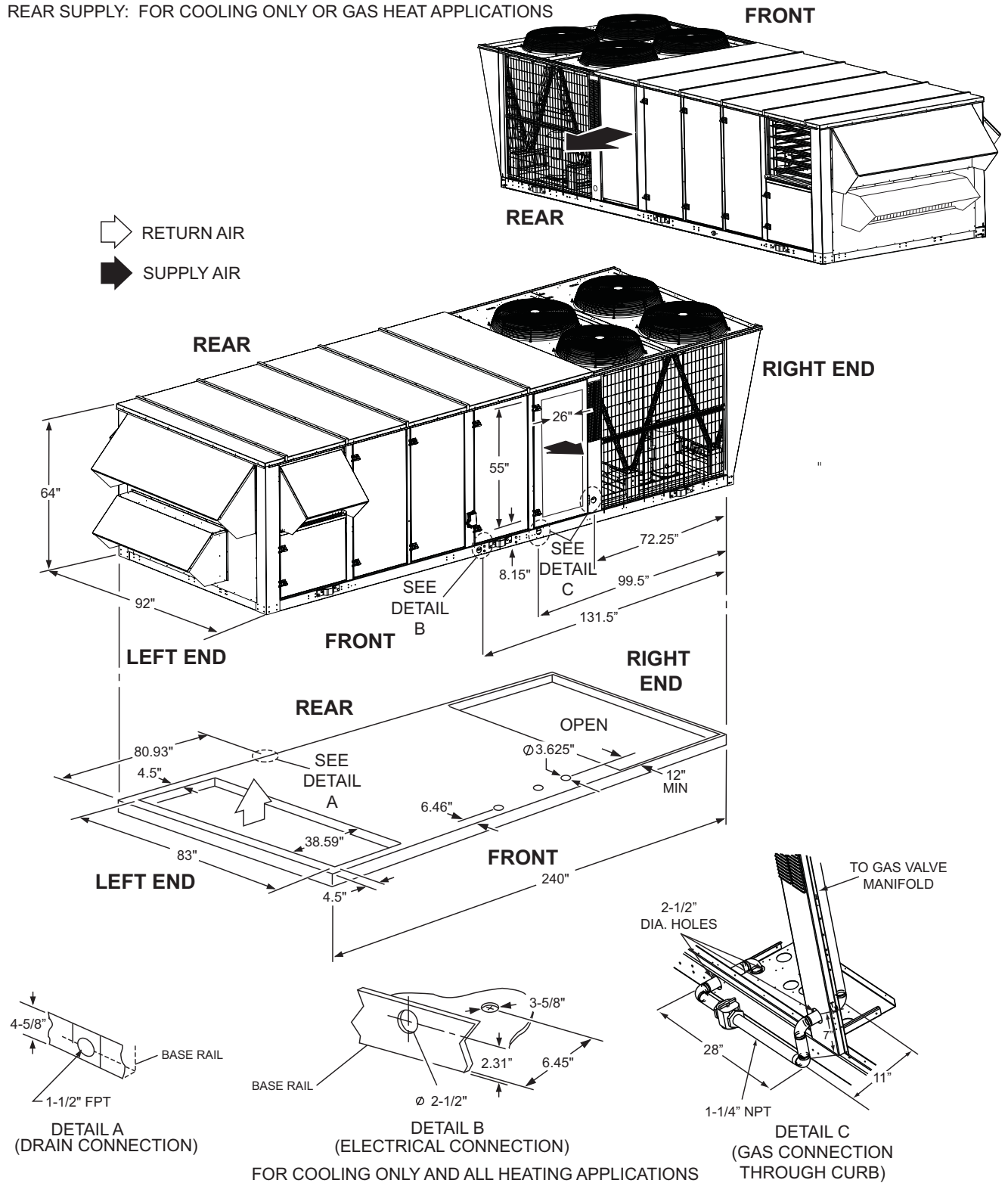

FIGURE 15 - BOTTOM RETURN, FRONT & REAR SUPPLY

FRONT SUPPLY: FOR COOLING ONLY APPLICATIONS
 REAR SUPPLY: FOR COOLING ONLY OR GAS HEAT APPLICATIONS

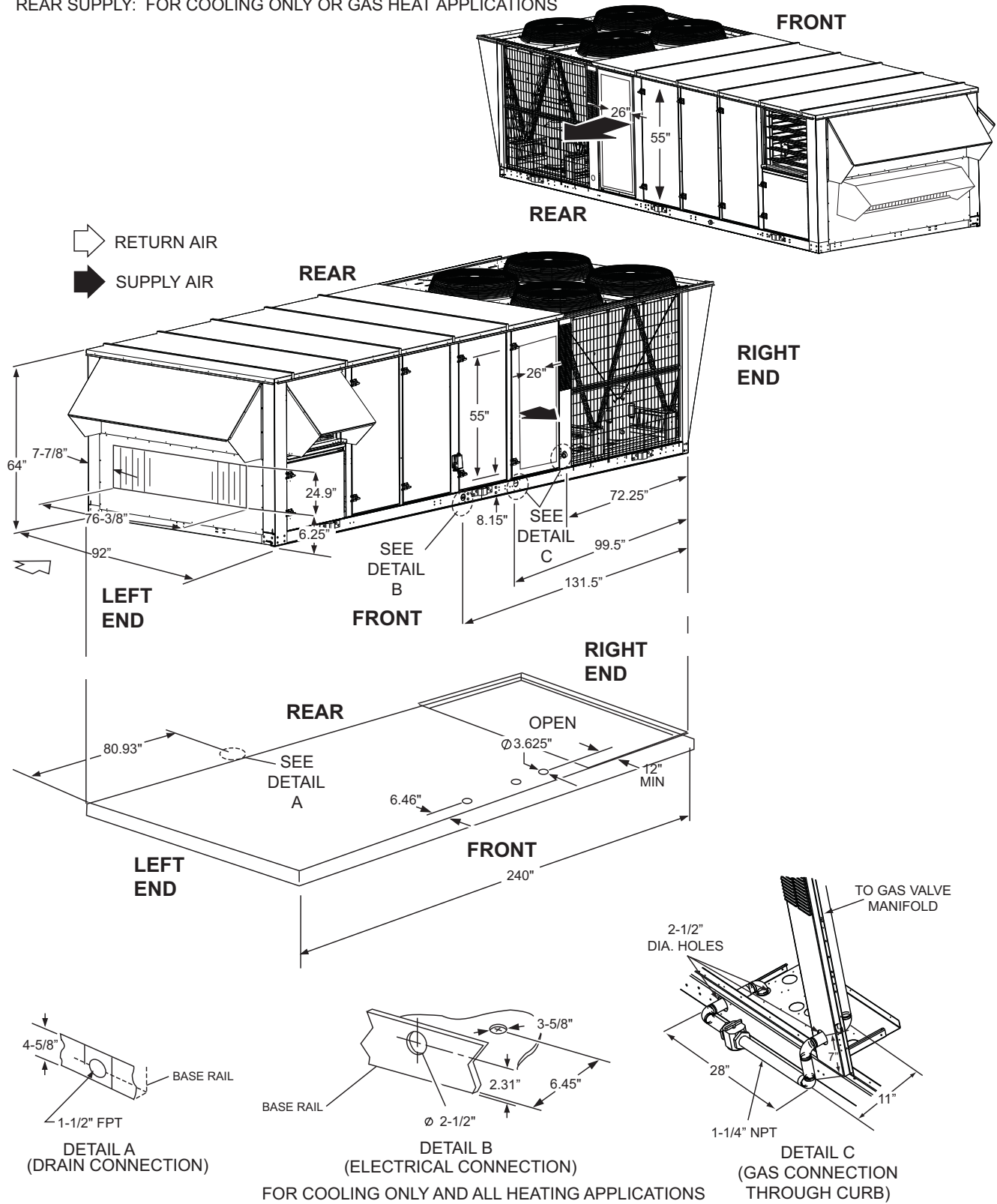

FIGURE 16 - END RETURN, FRONT & REAR SUPPLY

TABLE 15: GENERAL PHYSICAL DATA

UNIT SIZE	25 TON	30 TON	40 TON
UNIT EER	10.5	10.5	10.7
UNIT IEER CV	11.9	11.6	11.0
UNIT IEER DS (INTLLISPEED)	13.3	13.5	13.6
UNIT IEER VAV	13.8	13.3	13.6
COMPRESSOR DATA			
NUMBER/SIZE	4 x 5.7 Ton	4 x 7 Ton	4 x 8.6 Ton
TYPE	Scroll	Scroll	Scroll
UNIT CAPACITY STEPS	25%, 50%, 75%, 100%	25%, 50%, 75%, 100%	25%, 50%, 75%, 100%
INDOOR FAN AND DRIVE			
NUMBER / TYPE	1 / FC	1 / FC	1 / FC
DIAMETER X WIDTH (INCHES)	22 x 20	22 x 20	25 x 22
HP RANGE	7.5 - 20	10 - 25	10 - 25
CFM RANGE (FULL LOAD)	6,000 - 12,500	6,000 - 15,000	8,000 - 18,000
ESP RANGE	0.2" - 4.0"	0.2" - 4.0"	0.2" - 4.0"
EXHAUST FAN			
NUMBER/SIZE/TYPE	1/FC	2/FC	2/FC
HP RANGE (SINGLE MOTOR)	5 - 10	7.5 - 15	7.5 - 15
CFM	3,000 - 9,000	4,000 - 15,000	4,000 - 18,000
EVAPORATOR COIL			
SIZE (SQ. FT.)	26.0	26.0	30.4
ROWS/FPI	3 / 16	4 / 16	4 / 16
CONDENSER COIL			
SIZE (SQ. FT.)	65	104	104
ROWS/FPI	2/16	2 / 16	2 / 16
CONDENSER FANS			
QUANTITY / DIAMETER (INCHES)	4 / 24	4 / 30	4 / 30
NOMINAL CFM	6,800	8,770	9,460
MOTOR HP	1.0	1.5	1.5
ELECTRIC HEAT			
KW RANGE	40 - 108	40 - 108	40 - 108
40 kW / CAPACITY STEPS (CV/VAV)	1	1	1
80 kW / CAPACITY STEPS (CV/VAV)	2 / 1	2 / 1	2 / 1
108 kW / CAPACITY STEPS (CV/VAV)	3 / 1	3 / 1	3 / 1
NATURAL GAS HEAT			
UNIT SIZE	25 TON	30 TON	40 TON
267 MBH CAPACITY STEPS (CV/VAV)	1 / 1	1 / 1	1 / 1
533 MBH CAPACITY STEPS (CV/VAV)	2 / 1	2 / 1	2 / 1
800 MBH CAPACITY STEPS (CV/VAV)	-	-	3 / 1
267 MBH "MODULATING" CAPACITY STEPS (CV ONLY)	6 / 1	6 / 1	6 / 1
533 MBH "MODULATING" CAPACITY STEPS (CV ONLY)	12 / 2	12 / 2	12 / 2
800 MBH "MODULATING" CAPACITY STEPS (CV ONLY)	-	-	17 / 3
HOT WATER COIL			
SIZE (INCHES)	22.5" x 65"	22.5" X 65"	22.5" X 65"
CAPACITY	25 Ton	30 Ton	40 Ton
STEAM COIL			
SIZE (INCHES)		21" X 65"	
TYPE		Steam Coil	
FILTERS 2" TA			
NUMBER / SIZE	4 / 16 x 25 & 6 / 20 x 25	4 / 16 x 25 & 6 / 20 x 25	4 / 16 x 25 & 6 / 20 x 25
FACE AREA (SQ. FT.)	30.4	30.4	30.4
FILTERS 2" PLEATED, 30%			
NUMBER / SIZE	4 / 16 x 25 & 6 / 20 x 25	4 / 16 x 25 & 6 / 20 x 25	4 / 16 x 25 & 6 / 20 x 25
FACE AREA (SQ. FT.)	30.4	30.4	30.4
FILTERS 65% RIGID W/ 2" TA PREFILTERS			
NUMBER / SIZE	4 / 16 x 25 & 6 / 20 x 25	4 / 16 x 25 & 6 / 20 x 25	4 / 16 x 25 & 6 / 20 x 25
FACE AREA (SQ. FT.)	30.4	30.4	30.4
FILTERS 95% RIGID W/ 2" TA PREFILTERS			
NUMBER / SIZE	4 ea. 16 x 25 / 6 ea. 20 x 25	4 ea. 16 x 25 / 6 ea. 20 x 25	4 ea. 16 x 25 / 6 ea. 20 x 25
FACE AREA (SQ. FT.)	30.4	30.4	30.4

TABLE 16: REFRIGERANT FACTORY CHARGE R-410A

UNIT (Tons)	MODEL	CHARGE			
		SYSTEM #1	SYSTEM #2	SYSTEM #3	SYSTEM #4
25	w/o HGBP	13lb 8oz	12lb 8oz	12lb 8oz	12lb 8oz
25	w/ HGBP	14lb	12lb 8oz	12lb 8oz	12lb 8oz
30	w/o HGBP	22lb 15oz	20lb 7.5oz	22lb 4oz	20lb 6oz
30	w/ HGBP	23lb 7oz	20lb 7.5oz	22lb 4oz	20lb 6oz
40	w/o HGBP	20lb 8oz	18lb 8oz	18lb 8oz	20 b
40	w/ HGBP	21 b	18lb 8oz	18lb 8oz	20 b

ELECTRICAL DATA

TABLE 17: ELECTRICAL DATA 25 TON 208/230 VOLT WITHOUT ERV

Voltage	Compressors (each)				OD Fan Motors (each)	Heat Option				Conv Outlet	Supply Blower Motor	Pwr Exh Motor	W/O Pwr Conv Outlet		With Pwr Conv Outlet				
													MCA ¹	Max Fuse ² / Breaker ³ Size	MCA ¹	Max Fuse ² / Breaker ³ Size			
	QTY	RLA	LRA	MCC	FLA	Model	kW	Stages	Amps	FLA	HP	FLA	HP	FLA	Amps	Amps	Amps	Amps	
208-3-60	4	22.4	149	35	4.5	None/Gas	-	-	-	11.5	7.5	24.2	-	-	138	150	149	150	
													5	16.7	155	175	166	175	
													7.5	24.2	162	175	174	175	
												10	30.8	170	200	182	200		
												10	30.8	-	-	146	175	158	175
														5	16.7	163	175	174	200
											7.5			24.2	170	200	182	200	
											15	46.2	10	30.8	177	200	188	200	
													-	-	165	200	177	200	
													5	16.7	182	225	194	225	
											20	59.4	7.5	24.2	190	225	201	225	
													10	30.8	196	225	208	250	
-	-	182	225	193	250														
230-3-60	4	22.4	149	35	4.3	None/Gas	-	-	-	10.4	7.5	22	-	-	134	150	145	150	
													5	15.2	150	150	160	175	
													7.5	22	156	175	167	175	
												10	28	164	175	174	200		
												10	28	-	-	142	150	152	175
														5	15.2	157	175	167	175
											7.5			22	164	175	174	200	
											15	42	10	28	170	175	180	200	
													-	-	159	200	170	200	
													5	15.2	175	200	185	225	
											20	54	7.5	22	181	200	192	225	
													10	28	187	225	198	225	
-	-	174	225	185	225														
208-3-60	4	22.4	149	35	4.5	E4	30	1	83	11.5	7.5	24.2	-	-	138	150	149	150	
													5	16.7	155	175	166	175	
													7.5	24.2	162	175	174	175	
												10	30.8	170	200	182	200		
												10	30.8	-	-	146	175	158	175
														5	16.7	163	175	174	200
											7.5			24.2	170	200	182	200	
											15	46.2	10	30.8	177	200	188	200	
													-	-	165	200	177	200	
													5	16.7	182	225	194	225	
											20	59.4	7.5	24.2	190	225	201	225	
													10	30.8	196	225	208	250	
-	-	182	225	193	250														
20	59.4	5	16.7	199	250	210	250												
		7.5	24.2	206	250	218	250												
		10	30.8	213	250	224	250												

TABLE 17: ELECTRICAL DATA 25 TON 208/230 VOLT WITHOUT ERV (Continued)

Voltage	Compressors (each)				OD Fan Motors (each)	Heat Option				Conv Outlet	Supply Blower Motor		Pwr Exh Motor		W/O Pwr Conv Outlet		With Pwr Conv Outlet	
															MCA ¹	Max Fuse ² / Breaker ³ Size	MCA ¹	Max Fuse ² / Breaker ³ Size
	QTY	RLA	LRA	MCC	FLA	Model	kW	Stages	Amps	FLA	HP	FLA	HP	FLA	Amps	Amps	Amps	Amps
230-3-60	4	22.4	149	35	4.3	E4	40	1	92	10.4	7.5	22	-	-	143	150	153	175
													5	15.2	158	175	168	175
													7.5	22	165	175	175	175
													10	28	172	200	182	200
											10	28	-	-	150	175	160	175
													5	15.2	165	175	176	200
													7.5	22	172	200	182	200
													10	28	178	200	188	200
											15	42	-	-	168	200	178	200
													5	15.2	183	225	193	225
													7.5	22	190	225	200	225
													10	28	196	225	206	225
											20	54	-	-	183	225	193	225
													5	15.2	198	250	208	250
													7.5	22	205	250	215	250
													10	28	211	250	221	250
208-3-60	4	22.4	149	35	4.5	E8	60.1	2	167	11.5	7.5	24.2	-	-	197	225	209	225
													5	16.7	214	225	225	250
													7.5	24.2	221	225	233	250
													10	30.8	230	250	241	250
											10	30.8	-	-	206	225	217	225
													5	16.7	222	250	234	250
													7.5	24.2	230	250	241	250
													10	30.8	236	250	248	250
											15	46.2	-	-	225	250	236	250
													5	16.7	241	250	253	300
													7.5	24.2	249	250	260	300
													10	30.8	256	300	267	300
											20	59.4	-	-	241	300	253	300
													5	16.7	258	300	269	300
													7.5	24.2	265	300	277	300
													10	30.8	272	300	284	300
230-3-60	4	22.4	149	35	4.3	E8	80	2	185	10.4	7.5	22	-	-	213	250	223	250
													5	15.2	228	250	238	250
													7.5	22	235	250	245	250
													10	28	242	250	252	300
											10	28	-	-	220	250	230	250
													5	15.2	235	250	246	250
													7.5	22	242	250	252	300
													10	28	248	250	258	300
											15	42	-	-	238	250	248	250
													5	15.2	253	300	263	300
													7.5	22	260	300	270	300
													10	28	266	300	276	300
											20	54	-	-	253	300	263	300
													5	15.2	268	300	278	300
													7.5	22	275	300	285	300
													10	28	281	300	291	300

1. Minimum Circuit Ampacity.
2. Dual Element, Time Delay Type.
3. HACR type per NEC.

TABLE 18: ELECTRICAL DATA 25 TON 230 VOLT WITH ERV

Voltage	Compressors (each)				OD Fan Motors (Qty 4)	Heat Option				Conv Outlet	Supply Blower Motor		ERV Wheel Motor		ERV Blower Motor (Qty 2)		W/O Pwr'd Conv Outlet		With Pwr'd Conv Outlet	
																	MCA ¹	Max Fuse ² / Breaker ³ Size	MCA ¹	Max Fuse ² / Breaker ³ Size
	QTY	RLA	LRA	MCC	FLA	Model	kW	Stages	Amps	FLA	HP	FLA	HP	FLA	HP	FLA	Amps	Amps	Amps	Amps
208-3-60	4	22.4	149	35	4.5	None H2O Gas	-	-	-	11.5	7.5	24.2	0.25	2.5	5	16.7	174	175	185	200
											10	30.8					182	200	194	200
											15	46.2					201	225	213	250
											20	59.4					218	250	229	250
230-3-60	4	22.4	149	35	4.3	None H2O Gas	-	-	-	10.4	7.5	22	0.25	2.5	5	15.2	167	175	178	200
											10	28					175	200	185	200
											15	42					192	225	203	225
											20	54					207	250	218	250
208-3-60	4	22.4	149	35	4.5	E4	30	1	83	11.5	7.5	24.2	0.25	2.5	5	16.7	174	175	185	200
											10	30.8					182	200	194	200
											15	46.2					201	225	213	250
											20	59.4					218	250	229	250
230-3-60	4	22.4	149	35	4.3	E4	40	1	92	10.4	7.5	22	0.25	2.5	5	15.2	175	175	186	200
											10	28					183	200	193	200
											15	42					200	225	211	250
											20	54					215	250	226	250
208-3-60	4	22.4	149	35	4.5	E8	60.1	2	167	11.5	7.5	24.2	0.25	2.5	5	16.7	233	250	245	250
											10	30.8					241	250	253	300
											15	46.2					261	300	272	300
											20	59.4					277	300	289	300
230-3-60	4	22.4	149	35	4.3	E8	80	2	185	10.4	7.5	22	0.25	2.5	5	15.2	245	250	256	300
											10	28					253	300	263	300
											15	42					270	300	281	300
											20	54					285	300	296	350

1. Minimum Circuit Ampacity.
2. Dual Element, Time Delay Type.
3. HACR type per NEC.

TABLE 19: ELECTRICAL DATA 25 TON 460 VOLT WITHOUT ERV

Voltage	Compressors (each)				OD Fan Motors (each)	Heat Option				Conv Outlet	Supply Blower Motor		Pwr Exh Motor	W/O Pwr Conv Outlet		With Pwr Conv Outlet		
														MCA ¹	Max Fuse ² / Breaker ³ Size	MCA ¹	Max Fuse ² / Breaker ³ Size	
	QTY	RLA	LRA	MCC	FLA	Model	kW	Stages	Amps	FLA	HP	FLA	HP	FLA	Amps	Amps	Amps	Amps
460-3-60	4	10.6	75	16.5	2.15	None/Gas	-	-	-	5.2	7.5	11	-	-	65	70	70	80
													5	7.6	72	80	78	80
													7.5	11	76	80	81	90
													10	14	80	90	85	90
													-	-	69	80	74	80
													5	7.6	76	90	81	90
													7.5	11	80	90	85	90
													10	14	83	90	88	100
													-	-	77	90	82	100
													5	7.6	85	100	90	110
													7.5	11	88	100	93	110
													10	14	91	110	96	110
460-3-60	4	10.6	75	16.5	2.15	E4	40	1	46	5.2	7.5	11	-	-	71	80	76	80
													5	7.6	79	90	84	90
													7.5	11	82	90	87	90
													10	14	86	100	91	100
													-	-	75	80	80	90
													5	7.6	83	90	88	100
													7.5	11	86	100	91	100
													10	14	89	100	94	100
													-	-	84	100	89	110
													5	7.6	91	110	97	110
													7.5	11	95	110	100	110
													10	14	98	110	103	110
460-3-60	4	10.6	75	16.5	2.15	E8	80	2	92	5.2	7.5	11	-	-	106	125	111	125
													5	7.6	113	125	119	125
													7.5	11	117	125	122	125
													10	14	121	125	126	150
													-	-	110	125	115	125
													5	7.6	117	125	122	125
													7.5	11	121	125	126	150
													10	14	124	125	129	150
													-	-	118	125	123	125
													5	7.6	126	150	131	150
													7.5	11	129	150	134	150
													10	14	132	150	137	150
460-3-60	4	10.6	75	16.5	2.15	E8	80	2	92	5.2	20	27	-	-	126	150	131	150
													5	7.6	133	150	139	150
													7.5	11	137	150	142	150
													10	14	140	150	145	150

TABLE 19: ELECTRICAL DATA 25 TON 460 VOLT WITHOUT ERV (Continued)

Voltage	Compressors (each)				OD Fan Motors (each)	Heat Option				Conv Outlet	Supply Blower Motor		Pwr Exh Motor		W/O Pwr Conv Outlet		With Pwr Conv Outlet											
															MCA ¹	Max Fuse ² / Breaker ³ Size	MCA ¹	Max Fuse ² / Breaker ³ Size										
	QTY	RLA	LRA	MCC	FLA	Model	kW	Stages	Amps	FLA	HP	FLA	HP	FLA	Amps	Amps	Amps	Amps										
460-3-60	4	10.6	75	16.5	2.15	E1	108	2	125	5.2	7.5	11	-	-	139	175	144	175										
													5	7.6	146	175	152	175										
													7.5	11	150	175	155	175										
													10	14	154	175	159	175										
											10	14	-	-	143	175	148	175										
													5	7.6	150	175	155	175										
													7.5	11	154	175	159	175										
											15	21	10	14	157	175	162	175										
													-	-	151	175	156	175										
													5	7.6	159	175	164	175										
											20	27	7.5	11	162	175	167	175										
													10	14	165	175	170	175										
													-	-	159	175	164	175										
													5	7.6	166	175	172	175										

- 1. Minimum Circuit Ampacity.
- 2. Dual Element, Time Delay Type.
- 3. HACR type per NEC.

TABLE 20: ELECTRICAL DATA 25 TON 460 VOLT WITH ERV

Voltage	Compressors (each)				OD Fan Motors (Qty 4)	Heat Option				Conv Outlet	Supply Blower Motor		ERV Wheel Motor		ERV Blower Motor (Qty 2)		W/O Pwr Conv Outlet		With Pwr Conv Outlet	
																	MCA ¹	Max Fuse ² / Breaker ³ Size	MCA ¹	Max Fuse ² / Breaker ³ Size
	QTY	RLA	LRA	MCC	FLA	Model	kW	Stages	Amps	FLA	HP	FLA	HP	FLA	HP	FLA	Amps	Amps	Amps	Amps
460-3-60	4	10.6	75	16.5	2.15	None H2O Gas	-	-	-	5.2	7.5	11	0.25	1.2	5	7.6	81	90	86	90
											10	14					85	90	90	100
											15	21					94	110	99	110
											20	27					101	125	106	125
460-3-60	4	10.6	75	16.5	2.15	E4	40	1	46	5.2	7.5	11	0.25	1.2	5	7.6	88	90	93	100
											10	14					91	100	97	110
											15	21					100	110	105	125
											20	27					108	125	113	125
460-3-60	4	10.6	75	16.5	2.15	E8	80	2	92	5.2	7.5	11	0.25	1.2	5	7.6	122	125	127	150
											10	14					126	150	131	150
											15	21					135	150	140	150
											20	27					142	150	147	150
460-3-60	4	10.6	75	16.5	2.15	E1	108	2	125	5.2	7.5	11	0.25	1.2	5	7.6	155	175	160	175
											10	14					159	175	164	175
											15	21					168	175	173	175
											20	27					175	200	180	200

- 1. Minimum Circuit Ampacity.
- 2. Dual Element, Time Delay Type.
- 3. HACR type per NEC.

TABLE 21: ELECTRICAL DATA 25 TON 575 VOLT WITHOUT ERV

Volt	Compressors (each)				OD Fan Motors (each)	Heat Option				Conv Outlet	Supply Blower Motor		Pwr Exh Motor	W/O Pwr Conv Outlet		With Pwr Conv Outlet		
														MCA ¹	Max Fuse ² / Breaker ³ Size	MCA ¹	Max Fuse ² / Breaker ³ Size	
	QTY	RLA	LRA	MCC	FLA	Model	kW	Stages	Amps	FLA	HP	FLA	HP	FLA	Amps	Amps	Amps	Amps
575-3-60	4	7.7	54	12	1.7	None/Gas	-	-	-	4.2	7.5	9	-	-	49	50	53	60
													5	6.1	55	60	59	60
													7.5	9	58	60	62	70
													10	11	60	70	65	70
													-	-	51	60	56	60
													5	6.1	57	60	62	70
											10	11	7.5	9	60	70	65	70
													10	11	62	70	67	70
													-	-	59	70	63	80
													5	6.1	65	80	69	80
													7.5	9	68	80	72	80
													10	11	70	80	74	90
15	17	-	-	65	80	69	90											
		5	6.1	71	90	75	90											
		7.5	9	74	90	78	100											
		10	11	76	90	80	100											
		-	-	61	70	65	70											
		5	6.1	67	70	72	80											
575-3-60	4	7.7	54	12	1.7	E4	40	1	40	4.2	7.5	9	-	-	61	70	65	70
													5	6.1	67	70	72	80
													7.5	9	70	70	74	80
													10	11	73	80	77	80
													-	-	64	70	68	70
													5	6.1	70	80	74	80
											10	11	7.5	9	73	80	77	80
													10	11	75	80	79	90
													-	-	71	80	75	90
													5	6.1	77	90	82	90
													7.5	9	80	90	84	100
													10	11	82	90	86	100
15	17	-	-	78	100	82	100											
		5	6.1	84	100	88	110											
		7.5	9	87	100	91	110											
		10	11	89	110	93	110											
		-	-	91	100	95	100											
		5	6.1	97	100	102	110											
575-3-60	4	7.7	54	12	1.7	E8	80	2	80	4.2	7.5	9	-	-	91	100	95	100
													5	6.1	97	100	102	110
													7.5	9	100	100	104	110
													10	11	103	110	107	110
													-	-	94	100	98	100
													5	6.1	100	110	104	110
											10	11	7.5	9	103	110	107	110
													10	11	105	110	109	110
													-	-	101	110	105	110
													5	6.1	107	110	112	125
													7.5	9	110	125	114	125
													10	11	112	125	116	125
15	17	-	-	108	125	112	125											
		5	6.1	114	125	118	125											
		7.5	9	117	125	121	125											
		10	11	119	125	123	125											
		-	-	101	110	105	110											
		5	6.1	107	110	112	125											
20	22	7.5	9	117	125	121	125											
		10	11	119	125	123	125											

TABLE 21: ELECTRICAL DATA 25 TON 575 VOLT WITHOUT ERV (Continued)

Volt	Compressors (each)				OD Fan Motors (each)	Heat Option				Conv Outlet	Supply Blower Motor		Pwr Exh Motor		W/O Pwr Conv Outlet		With Pwr Conv Outlet	
															MCA ¹	Max Fuse ² / Breaker ³ Size	MCA ¹	Max Fuse ² / Breaker ³ Size
	QTY	RLA	LRA	MCC	FLA	Model	kW	Stages	Amps	FLA	HP	FLA	HP	FLA	Amps	Amps	Amps	Amps
575-3-60	4	7.7	54	12	1.7	E1	108	2	108	4.2	7.5	9	-	-	119	150	123	150
													5	6.1	125	150	130	150
													7.5	9	128	150	132	150
													10	11	131	150	135	150
													-	-	122	150	126	150
													5	6.1	128	150	132	150
											10	11	7.5	9	131	150	135	150
													10	11	133	150	137	150
													-	-	129	150	133	150
													5	6.1	135	150	140	150
													7.5	9	138	150	142	150
													10	11	140	150	144	150
15	17	-	-	136	150	140	150											
		5	6.1	142	150	146	150											
		7.5	9	145	150	149	150											
		10	11	147	150	151	175											

1. Minimum Circuit Ampacity.
2. Dual Element, Time Delay Type.
3. HACR type per NEC.

TABLE 22: ELECTRICAL DATA 25 TON 575 VOLT WITH ERV

Volt	Compressors (each)				OD Fan Motors (Qty 4)	Heat Option				Conv Outlet	Supply Blower Motor		ERV Wheel Motor		ERV Blower Motor (Qty 2)		W/O Pwr Conv Outlet		With Pwr Conv Outlet	
																	MCA ¹	Max Fuse ² / Breaker ³ Size	MCA ¹	Max Fuse ² / Breaker ³ Size
	QTY	RLA	LRA	MCC	FLA	Model	kW	Stages	Amps	FLA	HP	FLA	HP	FLA	HP	FLA	Amps	Amps	Amps	Amps
575-3-60	4	7.7	54	12	1.7	None H2O Gas	-	-	-	4.2	7.5	9	0.25	0.95	5	6.1	62	70	66	70
											10	11					65	70	69	80
											15	17					72	80	76	90
											20	22					78	100	82	100
575-3-60	4	7.7	54	12	1.7	E4	40	1	40	4.2	7.5	9	0.25	0.95	5	6.1	74	80	79	80
											10	11					77	80	81	90
											15	17					84	100	89	100
											20	22					91	110	95	110
575-3-60	4	7.7	54	12	1.7	E8	80	2	80	4.2	7.5	9	0.25	0.95	5	6.1	104	110	109	110
											10	11					107	110	111	125
											15	17					114	125	119	125
											20	22					121	125	125	125
575-3-60	4	7.7	54	12	1.7	E1	108	2	108	4.2	7.5	9	0.25	0.95	5	6.1	132	150	137	150
											10	11					135	150	139	150
											15	17					142	150	147	150
											20	22					149	150	153	175

1. Minimum Circuit Ampacity.
2. Dual Element, Time Delay Type.
3. HACR type per NEC.

TABLE 23: ELECTRICAL DATA 30 TON 208/230 VOLT WITHOUT ERV

Volt	Compressors (each)				OD Fan Motors (each)	Heat Option				Conv Outlet	Supply Blower Motor		Pwr Exh Motor	W/O Pwr Conv Outlet		With Pwr Conv Outlet		
														MCA ¹	Max Fuse ² / Breaker ³ Size	MCA ¹	Max Fuse ² / Breaker ³ Size	
	QTY	RLA	LRA	MCC	FLA	Model	kW	Stages	Amps	FLA	HP	FLA	HP	FLA	Amps	Amps	Amps	Amps
208-3-60	4	25	164	39	5.8	None/Gas	-	-	-	11.5	10	30.8	-	-	162	175	173	200
													7.5	24.2	186	200	197	225
													10	30.8	193	200	204	225
													15	46.2	212	250	223	250
											15	46.2	-	-	181	225	192	225
													7.5	24.2	205	250	217	250
													10	30.8	212	250	223	250
													15	46.2	227	250	239	250
											20	59.4	-	-	197	250	209	250
													7.5	24.2	222	250	233	250
													10	30.8	228	250	240	250
											25	74.8	15	46.2	244	300	255	300
-	-	217	250	228	300													
7.5	24.2	241	300	252	300													
10	30.8	248	300	259	300													
230-3-60	4	25	164	39	5.8	None/Gas	-	-	-	10.4	10	28	-	-	158	175	169	175
													7.5	22	180	200	191	200
													10	28	186	200	197	225
													15	42	204	225	214	250
											15	42	-	-	176	200	186	225
													7.5	22	198	225	208	250
													10	28	204	225	214	250
											20	54	15	42	218	250	228	250
													-	-	191	225	201	250
													7.5	22	213	250	223	250
											25	68	10	28	219	250	229	250
													15	42	233	250	243	250
-	-	208	250	219	250													
7.5	22	230	250	241	300													
208-3-60	4	25	164	39	5.8	E4	30	1	83	11.5	10	30.8	-	-	162	175	173	200
													7.5	24.2	186	200	197	225
													10	30.8	193	200	204	225
													15	46.2	212	250	223	250
											15	46.2	-	-	181	225	192	225
													7.5	24.2	205	250	217	250
													10	30.8	212	250	223	250
													15	46.2	227	250	239	250
											20	59.4	-	-	197	250	209	250
													7.5	24.2	222	250	233	250
													10	30.8	228	250	240	250
											25	74.8	15	46.2	244	300	255	300
-	-	217	250	228	300													
7.5	24.2	241	300	252	300													
10	30.8	248	300	259	300													
208-3-60	4	25	164	39	5.8	E4	30	1	83	11.5	10	30.8	-	-	162	175	173	200
													7.5	24.2	186	200	197	225
													10	30.8	193	200	204	225
													15	46.2	212	250	223	250
											15	46.2	-	-	181	225	192	225
													7.5	24.2	205	250	217	250
													10	30.8	212	250	223	250
													15	46.2	227	250	239	250
											20	59.4	-	-	197	250	209	250
													7.5	24.2	222	250	233	250
													10	30.8	228	250	240	250
											25	74.8	15	46.2	244	300	255	300
-	-	217	250	228	300													
7.5	24.2	241	300	252	300													
10	30.8	248	300	259	300													
208-3-60	4	25	164	39	5.8	E4	30	1	83	11.5	10	30.8	-	-	162	175	173	200
													7.5	24.2	186	200	197	225
													10	30.8	193	200	204	225
													15	46.2	212	250	223	250
											15	46.2	-	-	181	225	192	225
													7.5	24.2	205	250	217	250
													10	30.8	212	250	223	250
													15	46.2	227	250	239	250
											20	59.4	-	-	197	250	209	250
													7.5	24.2	222	250	233	250
													10	30.8	228	250	240	250
											25	74.8	15	46.2	244	300	255	300
-	-	217	250	228	300													
7.5	24.2	241	300	252	300													
10	30.8	248	300	259	300													

TABLE 23: ELECTRICAL DATA 30 TON 208/230 VOLT WITHOUT ERV (Continued)

Volt	Compressors (each)				OD Fan Motors (each)	Heat Option				Conv Outlet	Supply Blower Motor		Pwr Exh Motor		W/O Pwr Conv Outlet		With Pwr Conv Outlet	
															MCA ¹	Max Fuse ² / Breaker ³ Size	MCA ¹	Max Fuse ² / Breaker ³ Size
	QTY	RLA	LRA	MCC	FLA	Model	kW	Stages	Amps	FLA	HP	FLA	HP	FLA	Amps	Amps	Amps	Amps
230-3-60	4	25	164	39	5.8	E4	40	1	92	10.4	10	28	-	-	158	175	169	175
													7.5	22	180	200	191	200
													10	28	186	200	197	225
													15	42	204	225	214	250
											15	42	-	-	176	200	186	225
													7.5	22	198	225	208	250
													10	28	204	225	214	250
											20	54	15	42	218	250	228	250
													-	-	191	225	201	250
													7.5	22	213	250	223	250
											25	68	10	28	219	250	229	250
													15	42	233	250	243	250
-	-	208	250	219	250													
208-3-60	4	25	164	39	5.8	E8	60.1	2	167	11.5	10	30.8	-	-	206	225	217	225
													7.5	24.2	230	250	241	250
													10	30.8	236	250	248	250
													15	46.2	256	300	267	300
											15	46.2	-	-	225	250	236	250
													7.5	24.2	249	250	260	300
													10	30.8	256	300	267	300
											20	59.4	15	46.2	271	300	282	300
													-	-	241	300	253	300
													7.5	24.2	265	300	277	300
											25	74.8	10	30.8	272	300	284	300
													15	46.2	287	300	299	350
-	-	261	300	272	300													
230-3-60	4	25	164	39	5.8	E8	80	2	185	10.4	10	28	-	-	220	250	230	250
													7.5	22	242	250	252	300
													10	28	248	250	258	300
													15	42	266	300	276	300
											15	42	-	-	238	250	248	250
													7.5	22	260	300	270	300
													10	28	266	300	276	300
											20	54	15	42	280	300	290	300
													-	-	253	300	263	300
													7.5	22	275	300	285	300
											25	68	10	28	281	300	291	300
													15	42	295	300	305	350
-	-	270	300	280	300													
		7.5	22	292	350	302	350											
		10	28	298	350	308	350											
		15	42	312	350	322	350											

1. Minimum Circuit Ampacity.
2. Dual Element, Time Delay Type.
3. HACR type per NEC.

TABLE 24: ELECTRICAL DATA 30 TON 208/230 VOLT WITH ERV

Volt	Compressors (each)				OD Fan Motors (Qty 4)	Heat Option				Conv Outlet	Supply Blower Motor		ERV Wheel Motor		ERV Blower Motor (Qty 2)		W/O Pwr'd Conv Outlet		With Pwr'd Conv Outlet	
																	MCA ¹	Max Fuse ² / Breaker ³ Size	MCA ¹	Max Fuse ² / Breaker ³ Size
	QTY	RLA	LRA	MCC	FLA	Model	kW	Stages	Amps	FLA	HP	FLA	HP	FLA	HP	FLA	Amps	Amps	Amps	Amps
208-3-60	4	25	164	39	5.8	None H2O Gas	-	-	-	11.5	10	30.8	0.25	2.5	5	16.7	198	225	209	225
															7.5	24.2	213	225	224	250
															5	16.7	217	250	228	250
															7.5	24.2	232	250	243	250
															5	16.7	233	250	245	300
															7.5	24.2	248	300	260	300
															5	16.7	253	300	264	300
															7.5	24.2	268	300	279	350
230-3-60	4	25	164	39	5.8	None H2O Gas	-	-	-	10.4	10	28	0.25	2.5	5	15.2	191	200	202	225
															7.5	22	205	225	215	225
															5	15.2	209	250	219	250
															7.5	22	222	250	233	250
															5	15.2	224	250	234	250
															7.5	22	237	250	248	300
															5	15.2	241	300	252	300
															7.5	22	255	300	265	300
208-3-60	4	25	164	39	5.8	E4	30	1	83	11.5	10	30.8	0.25	2.5	5	16.7	198	225	209	225
															7.5	24.2	213	225	224	250
															5	16.7	217	250	228	250
															7.5	24.2	232	250	243	250
															5	16.7	233	250	245	300
															7.5	24.2	248	300	260	300
															5	16.7	253	300	264	300
															7.5	24.2	268	300	279	350
230-3-60	4	25	164	39	5.8	E4	40	1	92	10.4	10	28	0.25	2.5	5	15.2	191	200	202	225
															7.5	22	205	225	215	225
															5	15.2	209	250	219	250
															7.5	22	222	250	233	250
															5	15.2	224	250	234	250
															7.5	22	237	250	248	300
															5	15.2	241	300	252	300
															7.5	22	255	300	265	300
208-3-60	4	25	164	39	5.8	E8	60.1	2	167	11.5	10	30.8	0.25	2.5	5	16.7	241	250	253	300
															7.5	24.2	256	300	268	300
															5	16.7	261	300	272	300
															7.5	24.2	276	300	287	300
															5	16.7	277	300	289	300
															7.5	24.2	292	350	304	350
															5	16.7	296	350	308	350
															7.5	24.2	311	350	323	350
230-3-60	4	25	164	39	5.8	E8	80	2	185	10.4	10	28	0.25	2.5	5	15.2	253	300	263	300
															7.5	22	267	300	277	300
															5	15.2	270	300	281	300
															7.5	22	284	300	294	300
															5	15.2	285	300	296	350
															7.5	22	299	350	309	350
															5	15.2	303	350	313	350
															7.5	22	317	350	327	350

1. Minimum Circuit Ampacity.
2. Dual Element, Time Delay Type.
3. HACR type per NEC.

TABLE 25: ELECTRICAL DATA 30 TON 460 VOLT WITHOUT ERV

Volt	Compressors (each)				OD Fan Motors (each)	Heat Option				Conv Outlet	Supply Blower Motor		Pwr Exh Motor	W/O Pwr Conv Outlet		With Pwr Conv Outlet			
														MCA ¹	Max Fuse ² / Breaker ³ Size	MCA ¹	Max Fuse ² / Breaker ³ Size		
	QTY	RLA	LRA	MCC	FLA	Model	kW	Stages	Amps	FLA	HP	FLA	HP	FLA	Amps	Amps	Amps	Amps	
460-3-60	4	12.2	100	19	2.9	None/Gas	-	-	-	5.2	10	14	-	-	78	90	83	90	
													7.5	11	89	100	94	100	
													10	14	92	100	97	110	
												15	21	101	110	106	125		
												15	21	-	-	87	100	92	110
														7.5	11	98	110	103	110
											10			14	101	110	106	125	
											20	27	15	21	108	125	113	125	
													-	-	94	110	99	125	
													7.5	11	105	125	110	125	
											25	34	10	14	108	125	113	125	
													15	21	115	125	120	125	
-	-	103	125	108	125														
460-3-60	4	12.2	100	19	2.9	E4	40	1	46	5.2	10	14	-	-	78	90	83	90	
													7.5	11	89	100	94	100	
													10	14	92	100	97	110	
												15	21	101	110	106	125		
												15	21	-	-	87	100	92	110
														7.5	11	98	110	103	110
											10			14	101	110	106	125	
											20	27	15	21	108	125	113	125	
													-	-	94	110	99	125	
													7.5	11	105	125	110	125	
											25	34	10	14	108	125	113	125	
													15	21	115	125	120	125	
-	-	103	125	108	125														
460-3-60	4	12.2	100	19	2.9	E8	80	2	92	5.2	10	14	-	-	110	125	115	125	
													7.5	11	121	125	126	150	
													10	14	124	125	129	150	
												15	21	132	150	137	150		
												15	21	-	-	118	125	123	125
														7.5	11	129	150	134	150
											10			14	132	150	137	150	
											20	27	15	21	139	150	144	150	
													-	-	126	150	131	150	
													7.5	11	137	150	142	150	
											25	34	10	14	140	150	145	150	
													15	21	147	150	152	175	
-	-	135	150	140	150														
25	34	7.5	11	146	175	151	175												
		10	14	149	175	154	175												
		15	21	156	175	161	175												

TABLE 25: ELECTRICAL DATA 30 TON 460 VOLT WITHOUT ERV (Continued)

Volt	Compressors (each)				OD Fan Motors (each)	Heat Option				Conv Outlet	Supply Blower Motor		Pwr Exh Motor	W/O Pwr Conv Outlet		With Pwr Conv Outlet				
														MCA ¹	Max Fuse ² / Breaker ³ Size	MCA ¹	Max Fuse ² / Breaker ³ Size			
	QTY	RLA	LRA	MCC	FLA	Model	kW	Stages	Amps	FLA	HP	FLA	HP	FLA	Amps	Amps	Amps	Amps		
460-3-60	4	12.2	100	19	2.9	E1	108	2	125	5.2	10	14	-	-	143	175	148	175		
													7.5	11	154	175	159	175		
													10	14	157	175	162	175		
													15	21	165	175	170	175		
											15	21	-	-	151	175	156	175		
													7.5	11	162	175	167	175		
													10	14	165	175	170	175		
											15	21	15	21	172	175	177	200		
													20	27	-	-	159	175	164	175
															7.5	11	170	175	175	200
											10	14			173	200	178	200		
											15	21	15	21	180	200	185	200		
													25	34	-	-	168	200	173	200
															7.5	11	179	200	184	200
											10	14			182	200	187	200		
											15	21	189	200	194	225				

1. Minimum Circuit Ampacity.
2. Dual Element, Time Delay Type.
3. HACR type per NEC.

TABLE 26: ELECTRICAL DATA 30 TON 460 VOLT WITH ERV

Volt	Compressors (each)				OD Fan Motors (Qty 4)	Heat Option				Conv Outlet	Supply Blower Motor		ERV Wheel Motor		ERV Blower Motor (Qty 2)		W/O Pwrd Conv Outlet		With Pwrd Conv Outlet	
																	MCA ¹	Max Fuse ^{2/} Breaker ³ Size	MCA ¹	Max Fuse ^{2/} Breaker ³ Size
	QTY	RLA	LRA	MCC	FLA	Model	kW	Stages	Amps	FLA	HP	FLA	HP	FLA	HP	FLA	Amps	Amps	Amps	Amps
460-3-60	4	12.2	100	19	2.9	None H2O Gas	-	-	-	5.2	10	14	0.25	1.2	5	7.6	94	100	100	110
											15	21	0.25	1.2	5	7.6	103	110	108	125
											20	27	0.25	1.2	5	7.6	111	125	116	125
											25	34	0.25	1.2	5	7.6	119	150	125	150
460-3-60	4	12.2	100	19	2.9	E4	40	1	46	5.2	10	14	0.25	1.2	5	7.6	94	100	100	110
											15	21	0.25	1.2	5	7.6	103	110	108	125
											20	27	0.25	1.2	5	7.6	111	125	116	125
											25	34	0.25	1.2	5	7.6	119	150	125	150
460-3-60	4	12.2	100	19	2.9	E8	80	2	92	5.2	10	14	0.25	1.2	5	7.6	126	150	131	150
											15	21	0.25	1.2	5	7.6	135	150	140	150
											20	27	0.25	1.2	5	7.6	142	150	147	150
											25	34	0.25	1.2	5	7.6	151	175	156	175
460-3-60	4	12.2	100	19	2.9	E1	108	2	125	5.2	10	14	0.25	1.2	5	7.6	159	175	164	175
											15	21	0.25	1.2	5	7.6	168	175	173	175
											20	27	0.25	1.2	5	7.6	175	200	180	200
											25	34	0.25	1.2	5	7.6	184	200	189	200

1. Minimum Circuit Ampacity.
2. Dual Element, Time Delay Type.
3. HACR type per NEC.

TABLE 27: ELECTRICAL DATA 30 TON 575 VOLT WITHOUT ERV

Volt	Compressors (each)				OD Fan Motors (each)	Heat Option				Conv Outlet	Supply Blower Motor		Pwr Exh Motor	W/O Pwr Conv Outlet		With Pwr Conv Outlet		
														MCA ¹	Max Fuse ² / Breaker ³ Size	MCA ¹	Max Fuse ² / Breaker ³ Size	
	QTY	RLA	LRA	MCC	FLA	Model	kW	Stages	Amps	FLA	HP	FLA	HP	FLA	Amps	Amps	Amps	Amps
575-3-60	4	9	78	14	2.2	None/Gas	-	-	-	4.2	10	11	-	-	59	70	63	70
													7.5	9	68	70	72	80
													10	11	70	80	74	80
													15	17	77	90	81	90
											15	17	-	-	66	80	70	80
													7.5	9	75	90	79	90
													10	11	77	90	81	90
													15	17	83	100	87	100
											20	22	-	-	72	90	77	90
													7.5	9	81	100	86	100
													10	11	83	100	88	110
													15	17	89	110	94	110
25	27	-	-	79	100	83	110											
		7.5	9	88	110	92	110											
		10	11	90	110	94	110											
		15	17	96	110	100	125											
575-3-60	4	9	78	14	2.2	E4	40	1	40	4.2	10	11	-	-	64	70	68	70
													7.5	9	73	80	77	80
													10	11	75	80	79	90
													15	17	82	90	86	100
											15	17	-	-	71	80	75	90
													7.5	9	80	90	84	100
													10	11	82	90	86	100
													15	17	88	100	92	100
											20	22	-	-	78	100	82	100
													7.5	9	87	100	91	110
													10	11	89	110	93	110
													15	17	95	110	99	110
25	27	-	-	84	110	88	110											
		7.5	9	93	110	97	110											
		10	11	95	110	99	125											
		15	17	101	125	105	125											
575-3-60	4	9	78	14	2.2	E8	80	2	80	4.2	10	11	-	-	94	100	98	100
													7.5	9	103	110	107	110
													10	11	105	110	109	110
													15	17	112	125	116	125
											15	17	-	-	101	110	105	110
													7.5	9	110	125	114	125
													10	11	112	125	116	125
													15	17	118	125	122	125
											20	22	-	-	108	125	112	125
													7.5	9	117	125	121	125
													10	11	119	125	123	125
													15	17	125	125	129	150
25	27	-	-	114	125	118	125											
		7.5	9	123	150	127	150											
		10	11	125	150	129	150											
		15	17	131	150	135	150											

TABLE 27: ELECTRICAL DATA 30 TON 575 VOLT WITHOUT ERV (Continued)

Volt	Compressors (each)				OD Fan Motors (each)	Heat Option				Conv Outlet	Supply Blower Motor		Pwr Exh Motor	W/O Pwr Conv Outlet		With Pwr Conv Outlet												
														MCA ¹	Max Fuse ² / Breaker ³ Size	MCA ¹	Max Fuse ² / Breaker ³ Size											
	QTY	RLA	LRA	MCC	FLA	Model	kW	Stages	Amps	FLA	HP	FLA	HP	FLA	Amps	Amps	Amps	Amps										
575-3-60	4	9	78	14	2.2	E1	108	2	108	4.2	10	11	-	-	122	150	126	150										
													7.5	9	131	150	135	150										
													10	11	133	150	137	150										
													15	17	140	150	144	150										
											15	17	-	-	129	150	133	150										
													7.5	9	138	150	142	150										
													10	11	140	150	144	150										
											20	22	15	17	146	150	150	150										
													-	-	136	150	140	150										
													7.5	9	145	150	149	150										
											25	27	10	11	147	150	151	175										
													15	17	153	175	157	175										
													-	-	142	150	146	150										
													7.5	9	151	175	155	175										

1. Minimum Circuit Ampacity.
2. Dual Element, Time Delay Type.
3. HACR type per NEC.

TABLE 28: ELECTRICAL DATA 30 TON 575 VOLT WITH ERV

Volt	Compressors (each)				OD Fan Motors (Qty 4)	Heat Option				Conv Outlet	Supply Blower Motor		ERV Wheel Motor		ERV Blower Motor (Qty 2)		W/O Pwr'd Conv Outlet		With Pwr'd Conv Outlet	
																	MCA ¹	Max Fuse ² / Breaker ³ Size	MCA ¹	Max Fuse ² / Breaker ³ Size
	QTY	RLA	LRA	MCC	FLA	Model	kW	Stages	Amps	FLA	HP	FLA	HP	FLA	HP	FLA	Amps	Amps	Amps	Amps
575-3-60	4	9	78	14	2.2	None H2O Gas	-	-	-	4.2	10	11	0.25	0.95	5	6.1	72	80	76	80
															7.5	9	78	80	82	90
															5	6.1	79	90	83	100
															7.5	9	85	100	89	100
															5	6.1	85	100	90	110
															7.5	9	91	110	95	110
															5	6.1	92	110	96	110
															7.5	9	98	125	102	125
575-3-60	4	9	78	14	2.2	E4	40	1	40	4.2	10	11	0.25	0.95	5	6.1	77	80	81	90
															7.5	9	83	90	87	90
															5	6.1	84	100	89	100
															7.5	9	90	100	94	110
															5	6.1	91	110	95	110
															7.5	9	96	110	101	110
															5	6.1	97	110	101	125
															7.5	9	103	125	107	125
575-3-60	4	9	78	14	2.2	E8	80	2	80	4.2	10	11	0.25	0.95	5	6.1	107	110	111	125
															7.5	9	113	125	117	125
															5	6.1	114	125	119	125
															7.5	9	120	125	124	125
															5	6.1	121	125	125	125
															7.5	9	126	150	131	150
															5	6.1	127	150	131	150
															7.5	9	133	150	137	150
575-3-60	4	9	78	14	2.2	E1	108	2	108	4.2	10	11	0.25	0.95	5	6.1	135	150	139	150
															7.5	9	141	150	145	150
															5	6.1	142	150	147	150
															7.5	9	148	150	152	175
															5	6.1	149	150	153	175
															7.5	9	154	175	159	175
															5	6.1	155	175	159	175
															7.5	9	161	175	165	175

1. Minimum Circuit Ampacity.
2. Dual Element, Time Delay Type.
3. HACR type per NEC.

TABLE 29: ELECTRICAL DATA 40 TON 208/230 VOLT WITHOUT ERV

Volt	Compressors (each)				OD Fan Motors (each)	Heat Option				Conv Outlet	Supply Blower Motor		Pwr Exh Motor	W/O Pwr Conv Outlet		With Pwr Conv Outlet		
														MCA ¹	Max Fuse ² / Breaker ³ Size	MCA ¹	Max Fuse ² / Breaker ³ Size	
	QTY	RLA	LRA	MCC	FLA	Model	kW	Stages	Amps	FLA	HP	FLA	HP	FLA	Amps	Amps	Amps	Amps
208-3-60	4	28.2	240	44	5.8	None/Gas	-	-	-	11.5	10	30.8	-	-	175	200	186	200
													7.5	24.2	199	225	210	225
													10	30.8	205	225	217	225
													15	46.2	225	250	236	250
											15	46.2	-	-	194	225	205	250
													7.5	24.2	218	250	229	250
													10	30.8	225	250	236	250
													15	46.2	240	250	251	300
											20	59.4	-	-	210	250	222	250
													7.5	24.2	234	250	246	300
													10	30.8	241	300	253	300
													15	46.2	256	300	268	300
											25	74.8	-	-	230	300	241	300
													7.5	24.2	254	300	265	300
													10	30.8	260	300	272	300
													15	46.2	276	350	287	350
230-3-60	4	28.2	240	44	5.8	None/Gas	-	-	-	10.4	10	28	-	-	171	175	181	200
													7.5	22	193	200	203	225
													10	28	199	225	209	225
													15	42	217	250	227	250
											15	42	-	-	189	225	199	225
													7.5	22	211	250	221	250
													10	28	217	250	227	250
													15	42	231	250	241	250
											20	54	-	-	204	250	214	250
													7.5	22	226	250	236	250
													10	28	232	250	242	250
													15	42	246	300	256	300
											25	68	-	-	221	250	231	250
													7.5	22	243	300	253	300
													10	28	249	300	259	300
													15	42	263	300	273	300
208-3-60	4	28.2	240	44	5.8	E4	30	1	83	11.5	10	30.8	-	-	175	200	186	200
													7.5	24.2	199	225	210	225
													10	30.8	205	225	217	225
													15	46.2	225	250	236	250
											15	46.2	-	-	194	225	205	250
													7.5	24.2	218	250	229	250
													10	30.8	225	250	236	250
													15	46.2	240	250	251	300
											20	59.4	-	-	210	250	222	250
													7.5	24.2	234	250	246	300
													10	30.8	241	300	253	300
													15	46.2	256	300	268	300
											25	74.8	-	-	230	300	241	300
													7.5	24.2	254	300	265	300
													10	30.8	260	300	272	300
													15	46.2	276	350	287	350

TABLE 29: ELECTRICAL DATA 40 TON 208/230 VOLT WITHOUT ERV (Continued)

Volt	Compressors (each)				OD Fan Motors (each)	Heat Option				Conv Outlet	Supply Blower Motor		Pwr Exh Motor	W/O Pwr Conv Outlet		With Pwr Conv Outlet				
														MCA ¹	Max Fuse ² / Breaker ³ Size	MCA ¹	Max Fuse ² / Breaker ³ Size			
	QTY	RLA	LRA	MCC	FLA	Model	kW	Stages	Amps	FLA	HP	FLA	HP	FLA	Amps	Amps	Amps	Amps		
230-3-60	4	28.2	240	44	5.8	E4	40	1	92	10.4	10	28	-	-	171	175	181	200		
													7.5	22	193	200	203	225		
													10	28	199	225	209	225		
													15	42	217	250	227	250		
													15	42	-	-	189	225	199	225
															7.5	22	211	250	221	250
															10	28	217	250	227	250
													20	54	15	42	231	250	241	250
															-	-	204	250	214	250
															7.5	22	226	250	236	250
													25	68	10	28	232	250	242	250
															15	42	246	300	256	300
-	-	221	250	231	250															
208-3-60	4	28.2	240	44	5.8	E8	60.1	2	167	11.5	10	30.8	-	-	206	225	217	225		
													7.5	24.2	230	250	241	250		
													10	30.8	236	250	248	250		
													15	46.2	256	300	267	300		
													15	46.2	-	-	225	250	236	250
															7.5	24.2	249	250	260	300
															10	30.8	256	300	267	300
													20	59.4	15	46.2	271	300	282	300
															-	-	241	300	253	300
															7.5	24.2	265	300	277	300
													25	74.8	10	30.8	272	300	284	300
															15	46.2	287	300	299	350
-	-	261	300	272	300															
230-3-60	4	28.2	240	44	5.8	E8	80	2	185	10.4	10	28	-	-	220	250	230	250		
													7.5	22	242	250	252	300		
													10	28	248	250	258	300		
													15	42	266	300	276	300		
													15	42	-	-	238	250	248	250
															7.5	22	260	300	270	300
															10	28	266	300	276	300
													20	54	15	42	280	300	290	300
															-	-	253	300	263	300
															7.5	22	275	300	285	300
													25	68	10	28	281	300	291	300
															15	42	295	300	305	350
-	-	270	300	280	300															
25	68	7.5	22	292	350	302	350													
		10	28	298	350	308	350													
		15	42	312	350	322	350													

1. Minimum Circuit Ampacity.
2. Dual Element, Time Delay Type.
3. HACR type per NEC.

TABLE 30: ELECTRICAL DATA 40 TON 230 VOLT WITH ERV

Volt	Compressors (each)				OD Fan Motors (Qty 4)	Heat Option				Conv Outlet	Supply Blower Motor		ERV Wheel Motor		ERV Blower Motor (Qty 2)		W/O Pwr'd Conv Outlet		With Pwr'd Conv Outlet	
																	MCA ¹	Max Fuse ² / Breaker ³ Size	MCA ¹	Max Fuse ² / Breaker ³ Size
	QTY	RLA	LRA	MCC	FLA	Model	kW	Stages	Amps	FLA	HP	FLA	HP	FLA	HP	FLA	Amps	Amps	Amps	Amps
208-3-60	4	28.2	240	44	5.8	None H2O Gas	-	-	-	11.5	10	30.8	0.25	2.5	5	16.7	210	225	222	250
															7.5	24.2	225	250	237	250
															5	16.7	230	250	241	250
															7.5	24.2	245	250	256	300
															5	16.7	246	300	258	300
															7.5	24.2	261	300	273	300
															5	16.7	265	300	277	350
															7.5	24.2	280	350	292	350
230-3-60	4	28.2	240	44	5.8	None H2O Gas	-	-	-	10.4	10	28	0.25	2.5	5	15.2	204	225	214	225
															7.5	22	218	225	228	250
															5	15.2	221	250	232	250
															7.5	22	235	250	245	250
															5	15.2	236	250	247	300
															7.5	22	250	300	260	300
															5	15.2	254	300	264	300
															7.5	22	268	300	278	300
208-3-60	4	28.2	240	44	5.8	E4	30	1	83	11.5	10	30.8	0.25	2.5	5	16.7	210	225	222	250
															7.5	24.2	225	250	237	250
															5	16.7	230	250	241	250
															7.5	24.2	245	250	256	300
															5	16.7	246	300	258	300
															7.5	24.2	261	300	273	300
															5	16.7	265	300	277	350
															7.5	24.2	280	350	292	350
230-3-60	4	28.2	240	44	5.8	E4	40	1	92	10.4	10	28	0.25	2.5	5	15.2	204	225	214	225
															7.5	22	218	225	228	250
															5	15.2	221	250	232	250
															7.5	22	235	250	245	250
															5	15.2	236	250	247	300
															7.5	22	250	300	260	300
															5	15.2	254	300	264	300
															7.5	22	268	300	278	300
208-3-60	4	28.2	240	44	5.8	E8	60.1	2	167	11.5	10	30.8	0.25	2.5	5	16.7	241	250	253	300
															7.5	24.2	256	300	268	300
															5	16.7	261	300	272	300
															7.5	24.2	276	300	287	300
															5	16.7	277	300	289	300
															7.5	24.2	292	350	304	350
															5	16.7	296	350	308	350
															7.5	24.2	311	350	323	350
230-3-60	4	28.2	240	44	5.8	E8	80	2	185	10.4	10	28	0.25	2.5	5	15.2	253	300	263	300
															7.5	22	267	300	277	300
															5	15.2	270	300	281	300
															7.5	22	284	300	294	300
															5	15.2	285	300	296	350
															7.5	22	299	350	309	350
															5	15.2	303	350	313	350
															7.5	22	317	350	327	350

1. Minimum Circuit Ampacity.
2. Dual Element, Time Delay Type.
3. HACR type per NEC.

TABLE 31: ELECTRICAL DATA 40 TON 460 VOLT WITHOUT ERV

Volt	Compressors (each)				OD Fan Motors (each)	Heat Option				Conv Outlet	Supply Blower Motor		Pwr Exh Motor		W/O Pwr Conv Outlet		With Pwr Conv Outlet	
															MCA ¹	Max Fuse ² / Breaker ³ Size	MCA ¹	Max Fuse ² / Breaker ³ Size
	QTY	RLA	LRA	MCC	FLA	Model	kW	Stages	Amps	FLA	HP	FLA	HP	FLA	Amps	Amps	Amps	Amps
460-3-60	4	14.7	130	23	2.9	None/Gas	-	-	-	5.2	10	14	-	-	88	100	93	100
													7.5	11	99	110	104	110
													10	14	102	110	107	110
													15	21	111	125	116	125
													-	-	97	110	102	110
													7.5	11	108	125	113	125
											15	21	10	14	111	125	116	125
													15	21	118	125	123	125
													-	-	104	125	109	125
													7.5	11	115	125	120	125
													10	14	118	125	123	150
													15	21	125	150	130	150
20	27	-	-	113	125	118	150											
		7.5	11	124	150	129	150											
		10	14	127	150	132	150											
		15	21	134	150	139	150											
		-	-	113	125	118	150											
		7.5	11	124	150	129	150											
25	34	10	14	127	150	132	150											
		15	21	134	150	139	150											
		-	-	110	125	115	125											
		7.5	11	121	125	126	150											
		10	14	124	125	129	150											
		15	21	132	150	137	150											
460-3-60	4	14.7	130	23	2.9	E4	40	1	46	5.2	10	14	-	-	88	100	93	100
													7.5	11	99	110	104	110
													10	14	102	110	107	110
													15	21	111	125	116	125
													-	-	97	110	102	110
													7.5	11	108	125	113	125
											15	21	10	14	111	125	116	125
													15	21	118	125	123	125
													-	-	104	125	109	125
													7.5	11	115	125	120	125
													10	14	118	125	123	150
													15	21	125	150	130	150
20	27	-	-	113	125	118	150											
		7.5	11	124	150	129	150											
		10	14	127	150	132	150											
		15	21	134	150	139	150											
		-	-	113	125	118	150											
		7.5	11	124	150	129	150											
25	34	10	14	127	150	132	150											
		15	21	134	150	139	150											
		-	-	110	125	115	125											
		7.5	11	121	125	126	150											
		10	14	124	125	129	150											
		15	21	132	150	137	150											
460-3-60	4	14.7	130	23	2.9	E8	80	2	92	5.2	10	14	-	-	110	125	115	125
													7.5	11	121	125	126	150
													10	14	124	125	129	150
													15	21	132	150	137	150
													-	-	118	125	123	125
													7.5	11	129	150	134	150
											15	21	10	14	132	150	137	150
													15	21	139	150	144	150
													-	-	126	150	131	150
													7.5	11	137	150	142	150
													10	14	140	150	145	150
													15	21	147	150	152	175
20	27	-	-	135	150	140	150											
		7.5	11	146	175	151	175											
		10	14	149	175	154	175											
		15	21	156	175	161	175											
		-	-	135	150	140	150											
		7.5	11	146	175	151	175											
25	34	10	14	149	175	154	175											
		15	21	156	175	161	175											

TABLE 31: ELECTRICAL DATA 40 TON 460 VOLT WITHOUT ERV (Continued)

Volt	Compressors (each)				OD Fan Motors (each)	Heat Option				Conv Outlet	Supply Blower Motor		Pwr Exh Motor		W/O Pwr Conv Outlet		With Pwr Conv Outlet			
															MCA ¹	Max Fuse ² / Breaker ³ Size	MCA ¹	Max Fuse ² / Breaker ³ Size		
	QTY	RLA	LRA	MCC	FLA	Model	kW	Stages	Amps	FLA	HP	FLA	HP	FLA	Amps	Amps	Amps	Amps		
460-3-60	4	14.7	130	23	2.9	E1	108	2	125	5.2	10	14	-	-	143	175	148	175		
													7.5	11	154	175	159	175		
													10	14	157	175	162	175		
													15	21	165	175	170	175		
											15	21	-	-	151	175	156	175		
													7.5	11	162	175	167	175		
													10	14	165	175	170	175		
											15	21	15	21	172	175	177	200		
													20	27	-	-	159	175	164	175
															7.5	11	170	175	175	200
											10	14			173	200	178	200		
											20	27	15	21	180	200	185	200		
													25	34	-	-	168	200	173	200
															7.5	11	179	200	184	200
											10	14			182	200	187	200		
											15	21	189	200	194	225				

1. Minimum Circuit Ampacity.
2. Dual Element, Time Delay Type.
3. HACR type per NEC.

TABLE 32: ELECTRICAL DATA 40 TON 460 VOLT WITH ERV

Volt	Compressors (each)				OD Fan Motors (Qty 4)	Heat Option				Conv Outlet	Supply Blower Motor		ERV Wheel Motor		ERV Blower Motor (Qty 2)		W/O Pwr Conv Outlet		With Pwr Conv Outlet	
																	MCA ¹	Max Fuse ² / Breaker ³ Size	MCA ¹	Max Fuse ² / Breaker ³ Size
	QTY	RLA	LRA	MCC	FLA	Model	kW	Stages	Amps	FLA	HP	FLA	HP	FLA	HP	FLA	Amps	Amps	Amps	Amps
460-3-60	4	14.72	130	23	2.9	None H2O Gas	-	-	-	5.2	10	14	0.25	1.2	5	7.6	105	110	110	110
											15	21	0.25	1.2	5	7.6	113	125	117	125
											20	27	0.25	1.2	5	7.6	121	125	126	150
											25	34	0.25	1.2	5	7.6	129	150	135	150
460-3-60	4	14.72	130	23	2.9	E4	40	1	46	5.2	10	14	0.25	1.2	5	7.6	105	110	110	110
											15	21	0.25	1.2	5	7.6	113	125	118	125
											20	27	0.25	1.2	5	7.6	121	125	126	150
											25	34	0.25	1.2	5	7.6	129	150	135	150
460-3-60	4	14.72	130	23	2.9	E8	80	2	92	5.2	10	14	0.25	1.2	5	7.6	126	150	131	150
											15	21	0.25	1.2	5	7.6	135	150	140	150
											20	27	0.25	1.2	5	7.6	142	150	147	150
											25	34	0.25	1.2	5	7.6	151	175	156	175
460-3-60	4	14.72	130	23	2.9	E1	108	2	125	5.2	10	14	0.25	1.2	5	7.6	159	175	164	175
											15	21	0.25	1.2	5	7.6	168	175	173	175
											20	27	0.25	1.2	5	7.6	175	200	180	200
											25	34	0.25	1.2	5	7.6	184	200	189	200

1. Minimum Circuit Ampacity.
2. Dual Element, Time Delay Type.
3. HACR type per NEC.

TABLE 33: ELECTRICAL DATA 40 TON 575 VOLT WITHOUT ERV

Volt	Compressors (each)				OD Fan Motors (each)	Heat Option				Conv Outlet	Supply Blower Motor		Pwr Exh Motor	W/O Pwr Conv Outlet		With Pwr Conv Outlet		
														MCA ¹	Max Fuse ² / Breaker ³ Size	MCA ¹	Max Fuse ² / Breaker ³ Size	
	QTY	RLA	LRA	MCC	FLA	Model	kW	Stages	Amps	FLA	HP	FLA	HP	FLA	Amps	Amps	Amps	Amps
575-3-60	4	11.3	93.7	17.6	2.2	None/Gas	-	-	-	4.2	10	11	-	-	68	70	72	80
													7.5	9	77	80	81	90
													10	11	79	90	83	90
													15	17	86	100	90	100
											15	17	-	-	75	90	79	90
													7.5	9	84	100	88	100
													10	11	86	100	90	100
													15	17	92	100	96	110
											20	22	-	-	82	100	86	100
													7.5	9	91	110	95	110
													10	11	93	110	97	110
													15	17	99	110	103	125
25	27	-	-	88	110	92	110											
		7.5	9	97	110	101	125											
		10	11	99	125	103	125											
		15	17	105	125	109	125											
575-3-60	4	11.3	93.7	17.6	2.2	E4	40	1	40	4.2	10	11	-	-	68	70	72	80
													7.5	9	77	80	81	90
													10	11	79	90	83	90
													15	17	86	100	90	100
											15	17	-	-	75	90	79	90
													7.5	9	84	100	88	100
													10	11	86	100	90	100
													15	17	92	100	96	110
											20	22	-	-	82	100	86	100
													7.5	9	91	110	95	110
													10	11	93	110	97	110
													15	17	99	110	103	125
25	27	-	-	88	110	92	110											
		7.5	9	97	110	101	125											
		10	11	99	125	103	125											
		15	17	105	125	109	125											
575-3-60	4	11.3	93.7	17.6	2.2	E8	80	2	80	4.2	10	11	-	-	94	100	98	100
													7.5	9	103	110	107	110
													10	11	105	110	109	110
													15	17	112	125	116	125
											15	17	-	-	101	110	105	110
													7.5	9	110	125	114	125
													10	11	112	125	116	125
													15	17	118	125	122	125
											20	22	-	-	108	125	112	125
													7.5	9	117	125	121	125
													10	11	119	125	123	125
													15	17	125	125	129	150
25	27	-	-	114	125	118	125											
		7.5	9	123	150	127	150											
		10	11	125	150	129	150											
		15	17	131	150	135	150											

TABLE 33: ELECTRICAL DATA 40 TON 575 VOLT WITHOUT ERV (Continued)

Volt	Compressors (each)				OD Fan Motors (each)	Heat Option				Conv Outlet	Supply Blower Motor		Pwr Exh Motor	W/O Pwr Conv Outlet		With Pwr Conv Outlet					
														MCA ¹	Max Fuse ² / Breaker ³ Size	MCA ¹	Max Fuse ² / Breaker ³ Size				
	QTY	RLA	LRA	MCC	FLA	Model	kW	Stages	Amps	FLA	HP	FLA	HP	FLA	Amps	Amps	Amps	Amps			
575-3-60	4	11.3	93.7	17.6	2.2	E1	108	2	108	4	2	10	11	-	-	122	150	126	150		
														7.5	9	131	150	135	150		
														10	11	133	150	137	150		
														15	17	140	150	144	150		
														-	-	129	150	133	150		
														15	17	7.5	9	138	150	142	150
																10	11	140	150	144	150
																15	17	146	150	150	150
														20	22	-	-	136	150	140	150
																7.5	9	145	150	149	150
																10	11	147	150	151	175
																15	17	153	175	157	175
														25	27	-	-	142	150	146	150
																7.5	9	151	175	155	175
																10	11	153	175	157	175
																15	17	159	175	163	175

1. Minimum Circuit Ampacity.
2. Dual Element, Time Delay Type.
3. HACR type per NEC.

TABLE 34: ELECTRICAL DATA 40 TON 575 VOLT WITH ERV

Volt	Compressors (each)				OD Fan Motors (Qty 4)	Heat Option				Conv Outlet	Supply Blower Motor		ERV Wheel Motor		ERV Blower Motor (Qty 2)		W/O Pwr Conv Outlet		With Pwr Conv Outlet	
																	MCA ¹	Max Fuse ² / Breaker ³ Size	MCA ¹	Max Fuse ² / Breaker ³ Size
	QTY	RLA	LRA	MCC	FLA	Model	kW	Stages	Amps	FLA	HP	FLA	HP	FLA	HP	FLA	Amps	Amps	Amps	Amps
575-3-60	4	11.3	93.7	17.6	2.2	None H2O Gas	-	-	-	4.2	10	11	0.25	0.95	5	6.1	81	90	85	90
															7.5	9	87	90	91	100
															5	6.1	88	100	93	110
															7.5	9	94	110	98	110
															5	6.1	95	110	99	110
															7.5	9	100	110	105	125
															5	6.1	101	125	105	125
															7.5	9	107	125	111	125
575-3-60	4	11.3	93.7	17.6	2.2	E4	40	1	40	4.2	10	11	0.25	0.95	5	6.1	81	90	85	90
															7.5	9	87	90	91	100
															5	6.1	88	100	93	110
															7.5	9	94	110	98	110
															5	6.1	95	110	99	110
															7.5	9	100	110	105	125
															5	6.1	101	125	105	125
															7.5	9	107	125	111	125
575-3-60	4	11.3	93.7	17.6	2.2	E8	80	2	80	4.2	10	11	0.25	0.95	5	6.1	107	110	111	125
															7.5	9	113	125	117	125
															5	6.1	114	125	119	125
															7.5	9	120	125	124	125
															5	6.1	121	125	125	125
															7.5	9	126	150	131	150
															5	6.1	127	150	131	150
															7.5	9	133	150	137	150
575-3-60	4	11.3	93.7	17.6	2.2	E1	108	2	108	4.2	10	11	0.25	0.95	5	6.1	135	150	139	150
															7.5	9	141	150	145	150
															5	6.1	142	150	147	150
															7.5	9	148	150	152	175
															5	6.1	149	150	153	175
															7.5	9	154	175	159	175
															5	6.1	155	175	159	175
															7.5	9	161	175	165	175

1. Minimum Circuit Ampacity.
2. Dual Element, Time Delay Type.
3. HACR type per NEC.

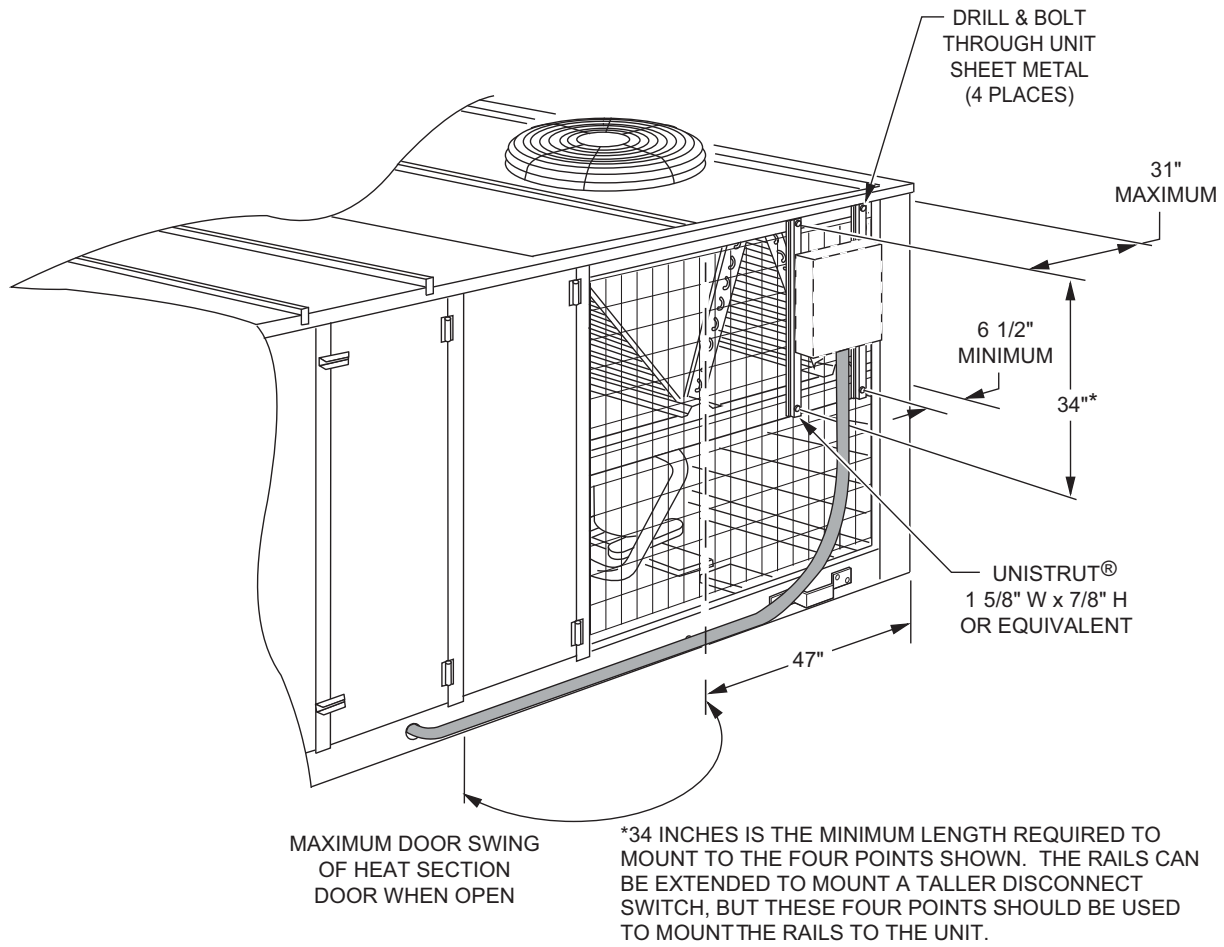
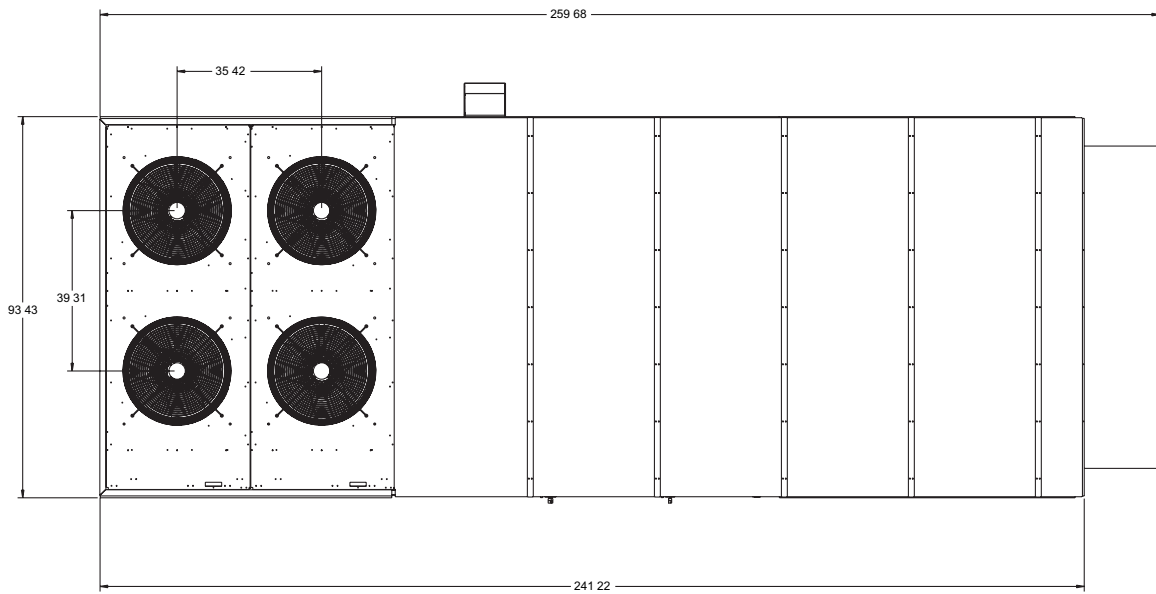
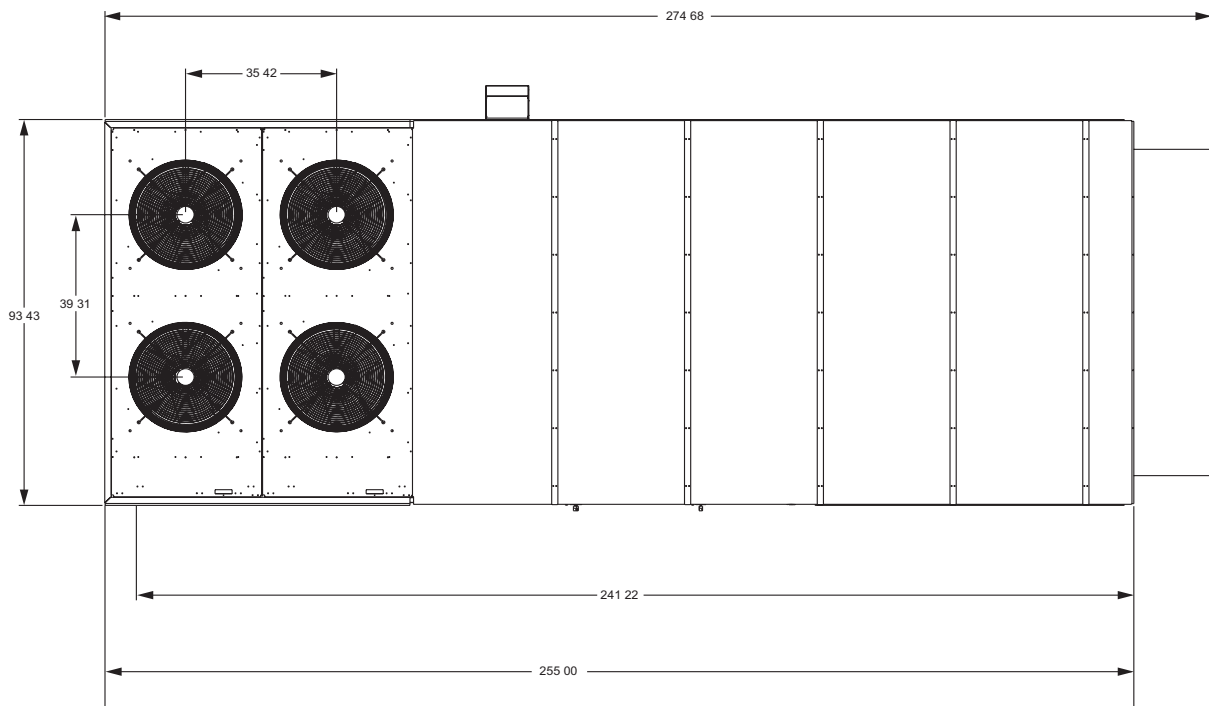

FIGURE 17 - FIELD INSTALLED DISCONNECT

**FIGURE 18 - 25 TON MILLENNIUM OVERHEAD VIEW****FIGURE 19 - 30 AND 40 TON MILLENNIUM OVERHEAD VIEW**

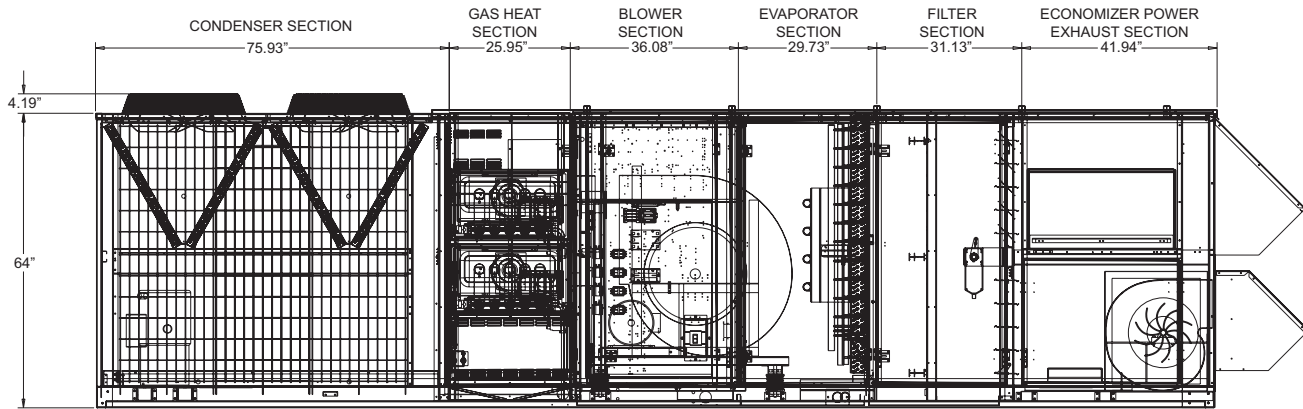

FIGURE 20 - 25 TON MILLENNIUM MAJOR COMPONENT LAYOUT

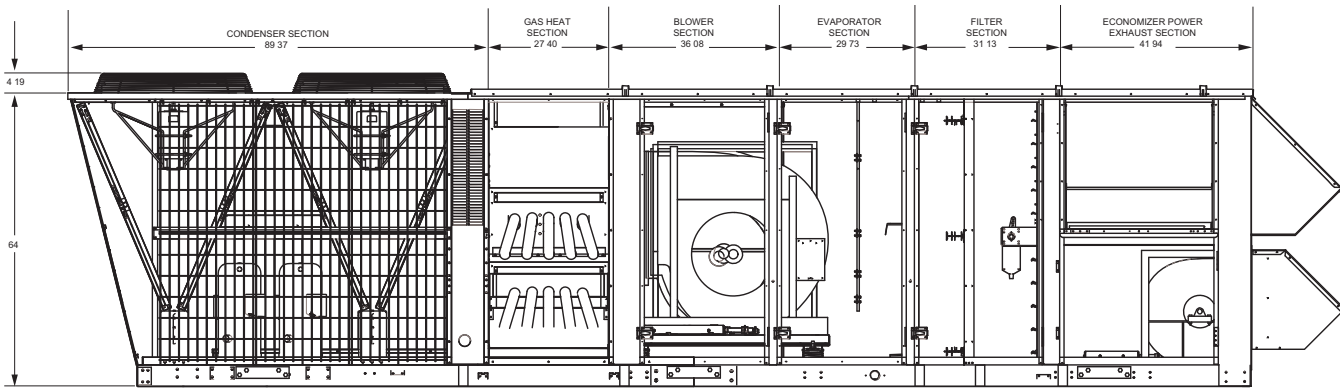
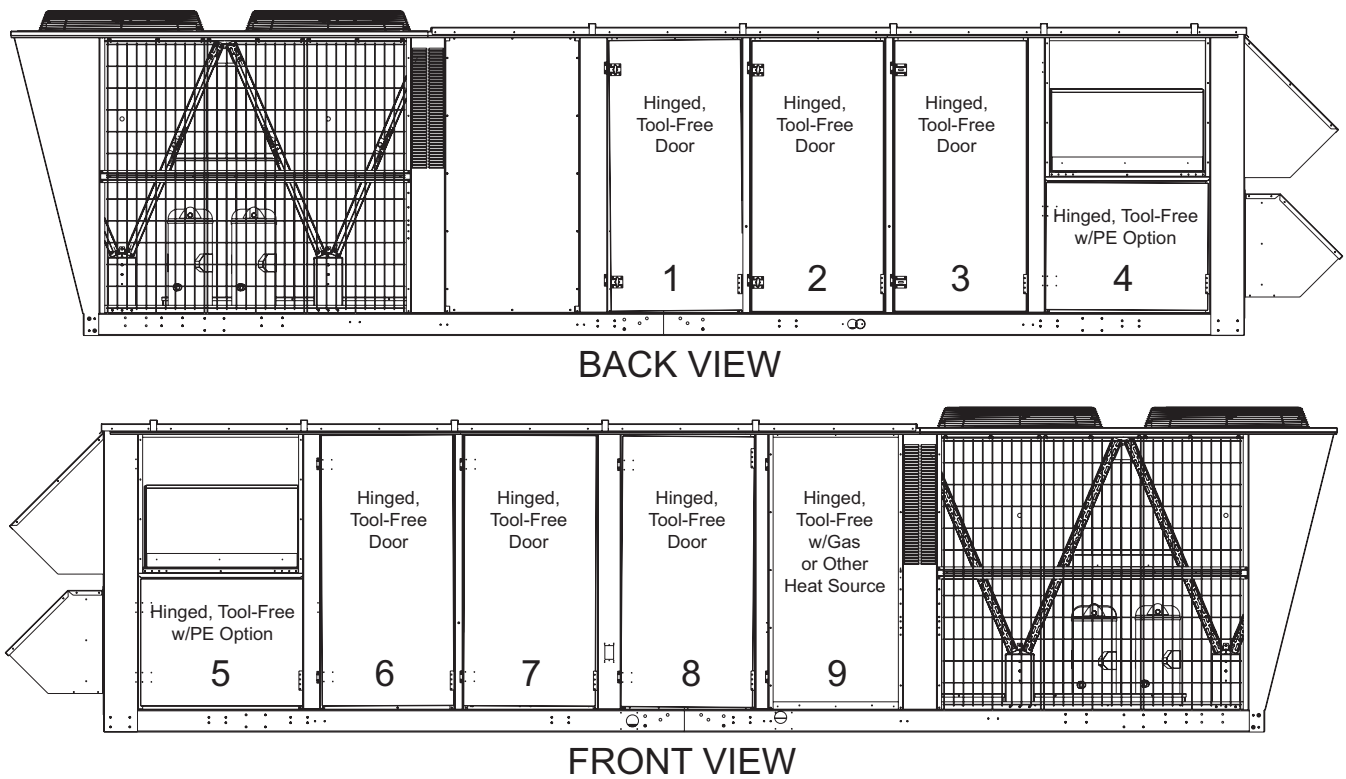

FIGURE 21 - 30 AND 40 TON MILLENNIUM MAJOR COMPONENT LAYOUT



1. STD Cabinet Option includes Hinged, Tool-Free Doors # 1, 3, 6, 8.
2. Premium Cabinet Option includes Hinged, Tool-Free Doors # 1, 2, 3, 6, 7, 8.
3. Doors # 4, 5, 9 are dependent upon unit Heating and Power Exhaust Options.
4. Doors 1, 2, 3, 6, 7, 8 & 9 are 56.31 inches high by 27.33 inches wide.
5. Doors 4 & 5 are 26.5 inches high by 33.63 inches wide.
6. Door configurations are the same on all tonnages (40 ton shown).

FIGURE 23 - MILLENNIUM CABINET DOOR CONFIGURATION

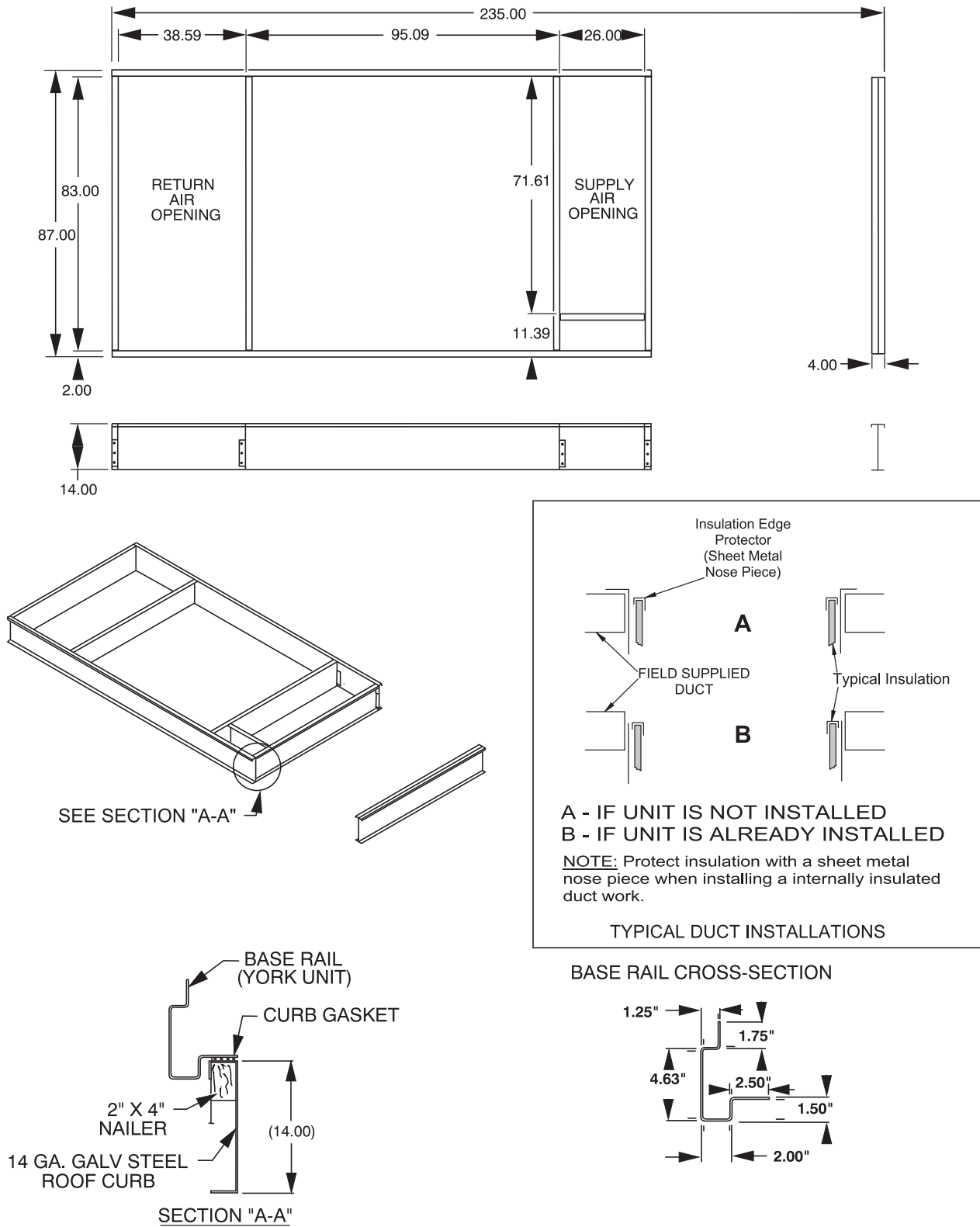

FIGURE 22 - PARTIAL ROOF CURB MODEL 1RC0455P

CFM, STATIC PRESSURE, AND POWER - ALTI-TUDE AND TEMPERATURE CORRECTIONS

The information below should be used to assist in application of product when being applied at altitudes at or exceeding 1000 feet above sea level.

The air flow rates listed in the standard blower performance tables are based on standard air at sea level. As the altitude or temperature increases, the density of air decreases. In

order to use the indoor blower tables for high altitude applications, certain corrections are necessary.

A centrifugal fan is a "constant volume" device. This means that, if the rpm remains constant, the CFM delivered is the same regardless of the density of the air. However, since the air at high altitude is less dense, less static pressure will be generated and less power will be required than a similar application at sea level. Air density correction factors are shown in Table 35 and Figure 24.

TABLE 35: ALTITUDE CORRECTION FACTORS

AIR TEMP	ALTITUDE (FEET)										
	0	1000	2000	3000	4000	5000	6000	7000	8000	9000	10000
40	1.060	1.022	0.986	0.950	0.916	0.882	0.849	0.818	0.788	0.758	0.729
50	1.039	1.002	0.966	0.931	0.898	0.864	0.832	0.802	0.772	0.743	0.715
60	1.019	0.982	0.948	0.913	0.880	0.848	0.816	0.787	0.757	0.729	0.701
70	1.000	0.964	0.930	0.896	0.864	0.832	0.801	0.772	0.743	0.715	0.688
80	0.982	0.947	0.913	0.880	0.848	0.817	0.787	0.758	0.730	0.702	0.676
90	0.964	0.929	0.897	0.864	0.833	0.802	0.772	0.744	0.716	0.689	0.663
100	0.946	0.912	0.880	0.848	0.817	0.787	0.758	0.730	0.703	0.676	0.651

The examples below will assist in determining the airflow performance of the product at altitude.

Example 1: What are the corrected CFM, static pressure, and BHP at an elevation of 5,000 ft. if the blower performance data is 6,000 CFM, 1.5 IWC and 4.0 BHP?

Solution: At an elevation of 5,000 ft the indoor blower will still deliver 6,000 CFM if the rpm is unchanged. However, Table 35 must be used to determine the static pressure and BHP. Since no temperature data is given, we will assume an air temperature of 70°F. Table 35 shows the correction factor to be 0.832.

$$\text{Corrected static pressure} = 1.5 \times 0.832 = 1.248 \text{ IWC}$$

$$\text{Corrected BHP} = 4.0 \times 0.832 = 3.328$$

Example 2: A system, located at 5,000 feet of elevation, is to deliver 6,000 CFM at a static pressure of 1.5". Use the unit blower tables to select the blower speed and the BHP requirement.

Solution: As in the example above, no temperature information is given so 70°F is assumed.

The 1.5" static pressure given is at an elevation of 5,000 ft. The first step is to convert this static pressure to equivalent sea level conditions.

$$\text{Sea level static pressure} = 1.5 / .832 = 1.80"$$

Enter the blower table at 6000 SCFM and static pressure of 1.8". The rpm listed will be the same rpm needed at 5,000 ft.

Suppose that the corresponding BHP listed in the table is 3.2. This value must be corrected for elevation.

$$\text{BHP at 5,000 ft} = 3.2 \times .832 = 2.66$$

Example 3: Plotting fan performance using the charts provided on pages 53, 55 & 57.

Refer to Figure 24, Fan Performance 40 Ton Example determine internal unit static loss. In this case the loss is approximately 1.6" IWC.

Plot the fan performance at cooling sea level 0' elevation. Design conditions: 40 ton unit producing 14,000 CFM @ 1.5 ESP with additional static losses for an economizer and 6", 65% air filters.

Economizer additional static loss = .28" IWC
Filter additional static loss 6", 65% = .46" IWC

Add the external static pressure and any additional losses to the internal static loss:

External static loss = 1.5" IWC
Economizer additional static loss = .28" IWC
Filter additional static loss 6", 65% = .46" IWC
Internal unit static loss = 1.6" IWC
Total system static = 3.84 IWC

Altitude/Temperature Conversion Factor

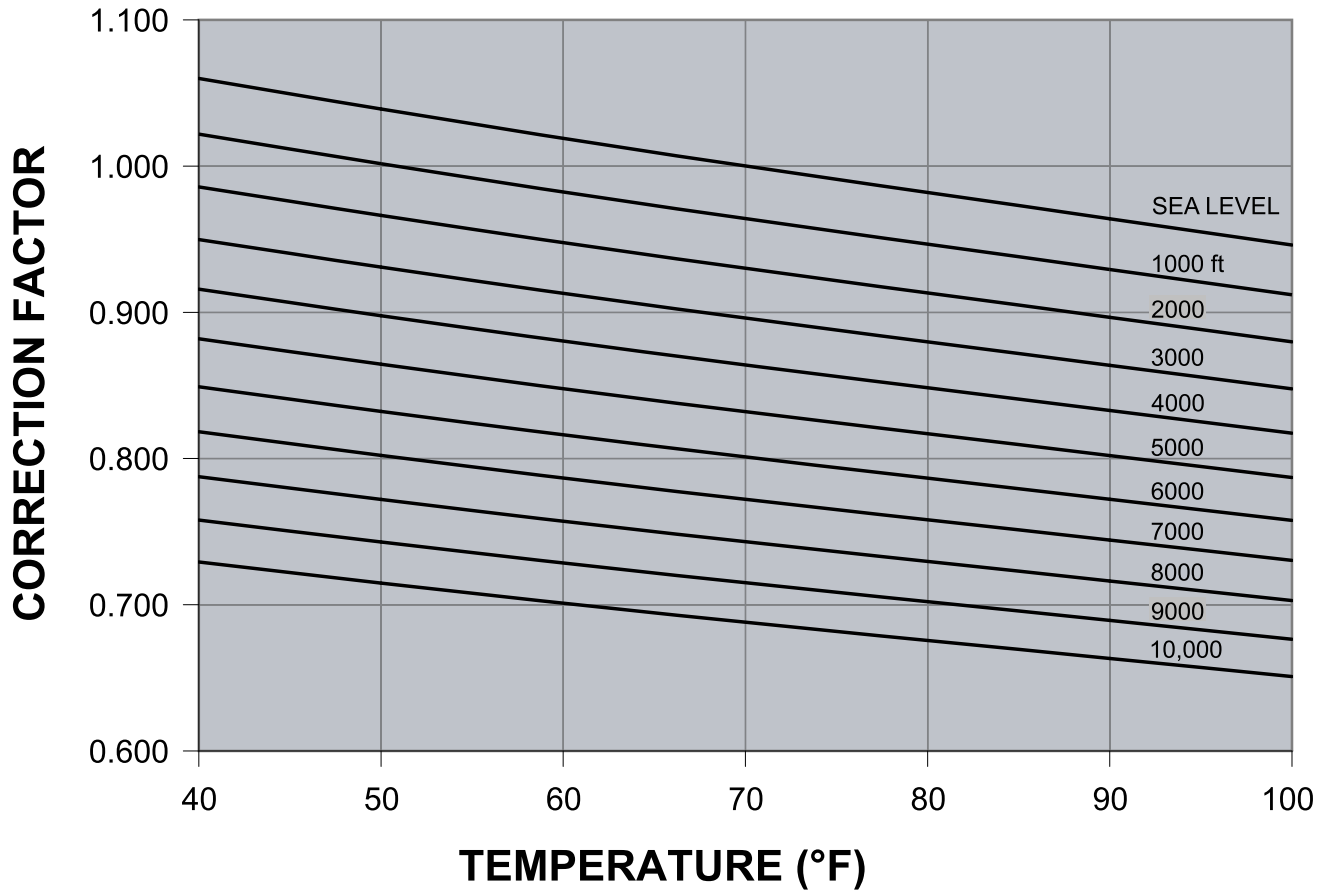

FIGURE 24 - ALTITUDE/TEMPERATURE CONVERSION FACTOR

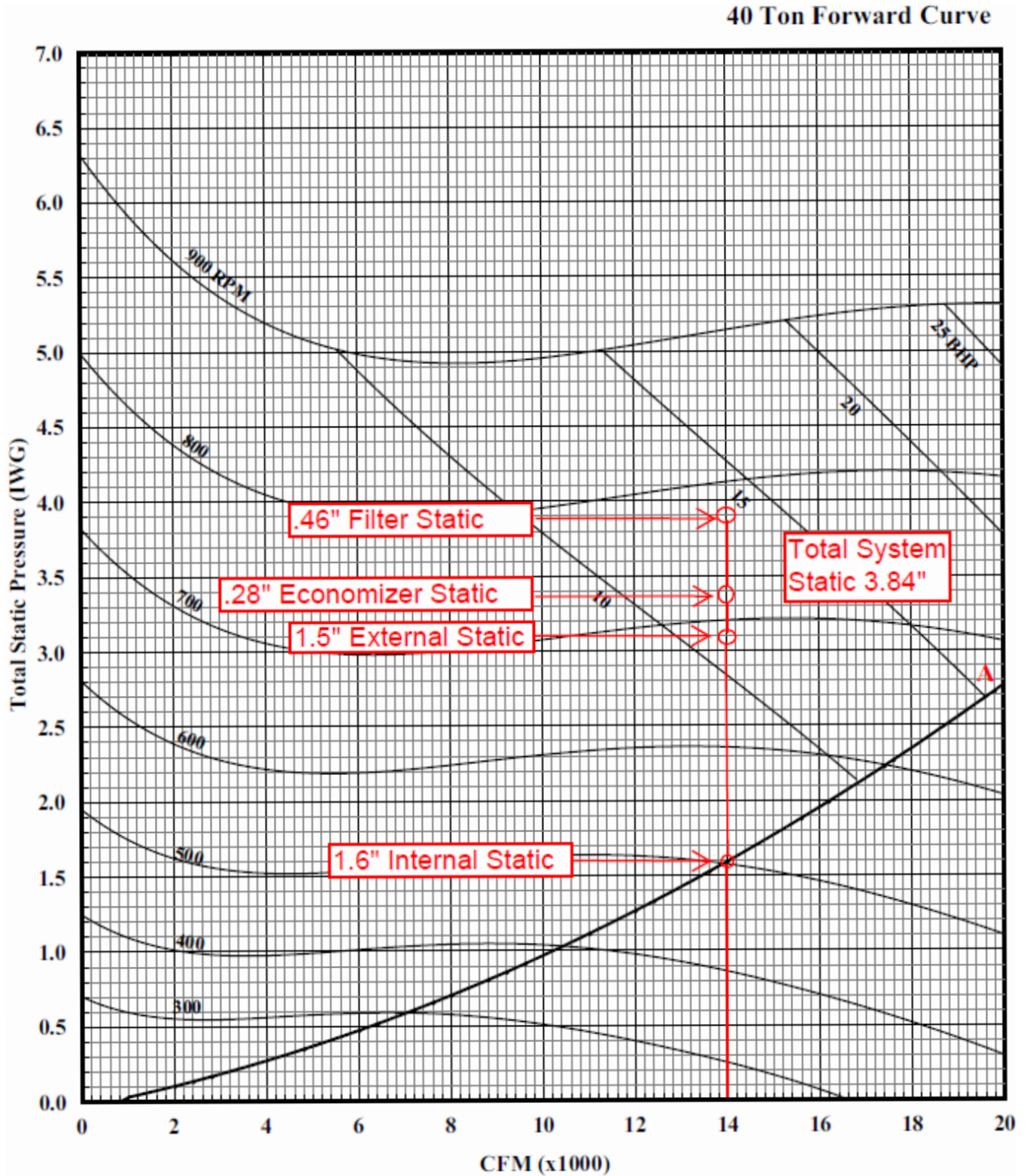

FIGURE 25 - 40 TON FORWARD CURVE EXAMPLE

TABLE 36: FAN PERFORMANCE - 25 TON^{1, 2}

AIRFLOW CFM	AVAILABLE EXTERNAL STATIC PRESSURE (IWG)									
	0.2		0.4		0.6		0.8		1.0	
	RPM	BHP ³	RPM	BHP ³	RPM	BHP ³	RPM	BHP ³	RPM	BHP ³
4000	302	0.5	365	0.7	422	1.0	475	1.3	523	1.5
5000	341	0.9	396	1.1	447	1.4	495	1.7	540	2.0
6000	380	1.2	427	1.5	473	1.8	516	2.1	557	2.5
7000	416	1.8	459	2.1	500	2.5	540	2.8	578	3.2
8000	452	2.3	491	2.7	528	3.1	565	3.5	600	3.9
9000	492	3.2	527	3.6	561	4.0	594	4.5	626	4.9
10000	532	4.2	563	4.5	594	4.9	624	5.4	653	5.8
11000	578	5.5	605	5.9	632	6.3	659	6.7	686	7.2
12000	623	6.8	647	7.2	671	7.6	695	8.1	719	8.6
12500	639	7.4	664	7.9	688	8.4	712	8.9	736	9.5

AIRFLOW CFM	AVAILABLE EXTERNAL STATIC PRESSURE (IWG)									
	1.2		1.4		1.6		1.8		2.0	
	RPM	BHP ³	RPM	BHP ³	RPM	BHP ³	RPM	BHP ³	RPM	BHP ³
4000	568	1.8	609	2.2	646	2.5	681	2.8	713	3.2
5000	582	2.4	621	2.7	657	3.1	692	3.5	724	3.9
6000	596	2.9	633	3.3	669	3.7	702	4.1	735	4.5
7000	615	3.6	650	4.0	683	4.5	716	4.9	747	5.4
8000	633	4.4	666	4.8	698	5.3	729	5.7	759	6.2
9000	658	5.3	688	5.8	718	6.3	747	6.8	776	7.3
10000	682	6.3	710	6.8	738	7.3	766	7.8	793	8.4
11000	713	7.7	739	8.2	765	8.8	791	9.3	816	9.9
12000	743	9.1	767	9.7	791	10.2	815	10.8	839	11.4
12500	760	10.0	784	10.6	807	11.2	830	11.7	853	12.3

AIRFLOW CFM	AVAILABLE EXTERNAL STATIC PRESSURE (IWG)									
	2.2		2.4		2.6		2.8		3.0	
	RPM	BHP ³	RPM	BHP ³	RPM	BHP ³	RPM	BHP ³	RPM	BHP ³
4000	743	3.5	770	3.9	796	4.3	821	4.6	844	5.0
5000	754	4.3	783	4.7	810	5.1	836	5.5	861	5.9
6000	766	5.0	795	5.4	824	5.9	851	6.4	878	6.8
7000	777	5.8	806	6.3	834	6.8	861	7.3	888	7.8
8000	788	6.7	817	7.2	844	7.7	871	8.2	898	8.8
9000	804	7.8	831	8.3	857	8.9	883	9.5	909	10.0
10000	819	8.9	845	9.5	870	10.1	896	10.7	920	11.3
11000	841	10.5	866	11.1	890	11.7	914	12.3	938	12.9
12000	863	12.0	887	12.6	910	13.2	933	13.9	956	14.5
12500	876	12.9	899	13.6	921	14.2	943	14.8	965	15.5

AIRFLOW CFM	AVAILABLE EXTERNAL STATIC PRESSURE (IWG)									
	3.2		3.4		3.6		3.8		4.0	
	RPM	BHP ³	RPM	BHP ³	RPM	BHP ³	RPM	BHP ³	RPM	BHP ³
4000	867	5.4	890	5.8	912	6.2	935	6.6	958	6.9
5000	885	6.4	909	6.8	932	7.2	956	7.6	979	8.0
6000	903	7.3	928	7.8	953	8.2	976	8.7	1000	9.1
7000	914	8.3	939	8.8	963	9.4	988	9.9	1012	10.5
8000	924	9.3	949	9.9	974	10.5	999	11.2	1023	11.8
9000	934	10.6	959	11.2	983	11.9	1007	12.5	1030	13.2
10000	944	11.9	968	12.6	992	13.2	1015	13.8	1037	14.5
11000	961	13.6	984	14.2	1007	14.9	1029	15.6	1051	16.2
12000	978	15.2	1000	15.9	1022	16.6	1043	17.3	1064	18.0
13000	986	16.2	1008	16.8	1029	17.5	1050	18.2	1070	19.0

1. Fan performance is based on wet evaporator coils, clean 2" throwaway filters and system/cabinet effects at standard air density and 0 feet elevation.
2. Refer to Tables 66, 15, 21 and 39 for component additions and deductions to fan performance tables.
3. BHP includes drive losses.
4. Shaded RPMs require Class II blower.

25 Ton Forward Curve

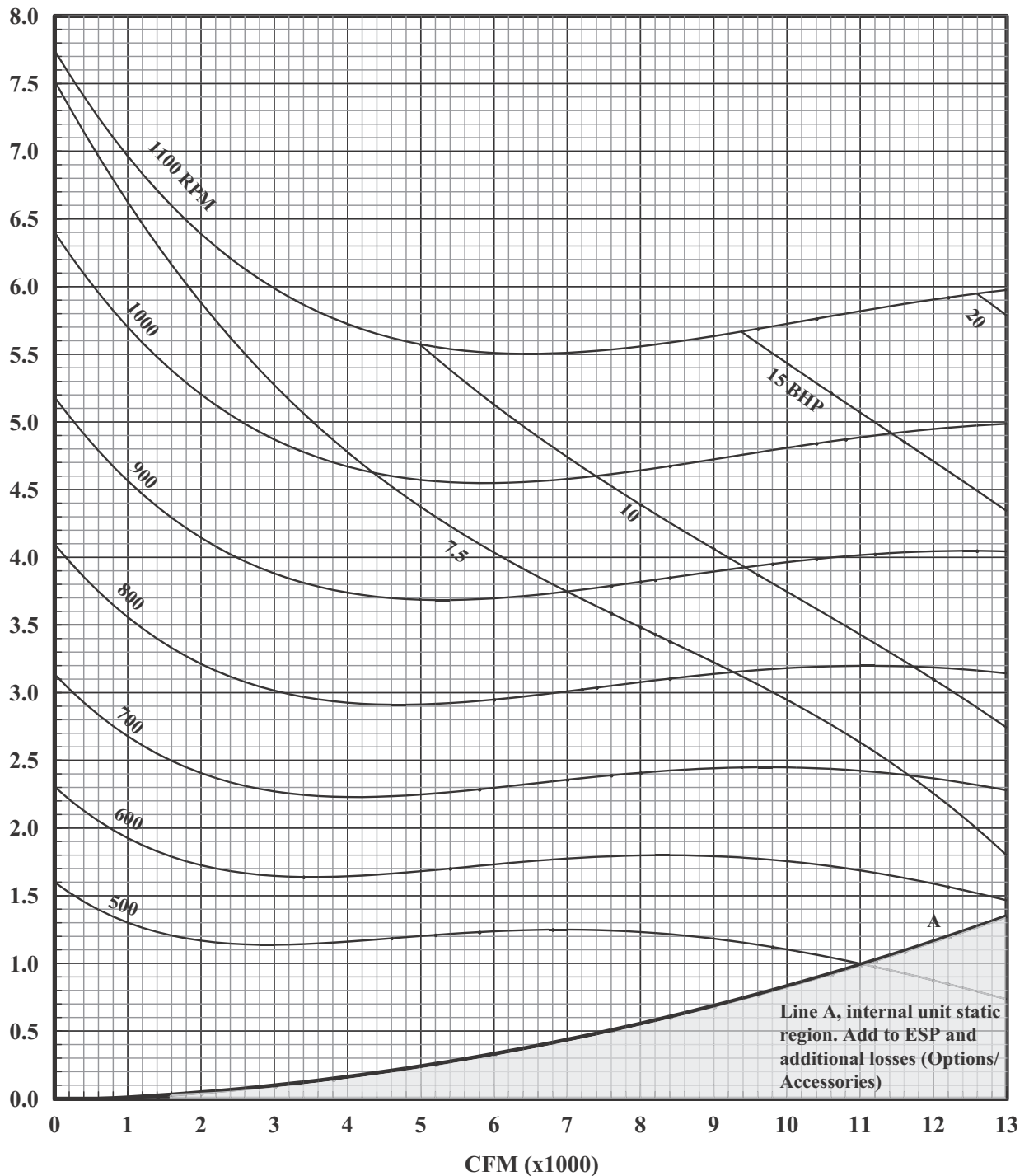

NOTE: All areas below the "A" curve are fixed, internal cabinet losses and should be considered when determining total system static and plotting unit fan performance.

NOTE: Standard Unit includes wet evaporator coil, clean 2" throwaway filters, system and cabinet effects at standard air density and 0' elevation.

FIGURE 26 - FAN PERFORMANCE - 25 TON

TABLE 37: FAN PERFORMANCE - 30 TON ^{1, 2}

AIRFLOW (CFM)	AVAILABLE EXTERNAL STATIC PRESSURE (IWG)									
	0.2		0.4		0.6		0.8		1.0	
	RPM	BHP ³	RPM	BHP ³	RPM	BHP ³	RPM	BHP ³	RPM	BHP ³
6000	405	1.3	450	1.6	494	2.0	535	2.3	575	2.7
7000	444	1.9	485	2.3	524	2.7	562	3.0	599	3.4
8000	483	2.6	519	2.9	555	3.3	589	3.7	623	4.2
9000	520	3.5	554	3.9	586	4.3	618	4.7	649	5.2
10000	558	4.5	588	4.8	618	5.2	647	5.7	676	6.2
11000	603	5.7	629	6.2	656	6.7	683	7.2	709	7.7
12000	647	7.0	671	7.5	695	8.1	718	8.6	742	9.2
13000	687	8.9	709	9.3	731	9.9	753	10.4	776	10.9
14000	728	10.7	748	11.2	768	11.6	789	12.2	809	12.7
15000	767	12.7	786	13.2	805	13.8	825	14.4	845	15.0

AIRFLOW (CFM)	AVAILABLE EXTERNAL STATIC PRESSURE (IWG)									
	1.2		1.4		1.6		1.8		2.0	
	RPM	BHP ³	RPM	BHP ³	RPM	BHP ³	RPM	BHP ³	RPM	BHP ³
6000	612	3.1	649	3.5	683	3.9	717	4.3	748	4.7
7000	634	3.8	668	4.3	701	4.7	733	5.1	763	5.6
8000	655	4.6	687	5.1	719	5.5	749	6.0	779	6.5
9000	680	5.6	710	6.1	739	6.6	768	7.2	796	7.7
10000	704	6.7	732	7.2	760	7.7	787	8.3	813	8.9
11000	735	8.2	761	8.7	787	9.3	812	9.8	837	10.4
12000	766	9.7	790	10.3	814	10.8	837	11.4	861	12.0
13000	798	11.5	820	12.1	843	12.7	865	13.3	887	13.9
14000	830	13.3	851	13.9	872	14.6	893	15.2	914	15.9
15000	864	15.6	884	16.3	904	16.9	923	17.6	943	18.3

AIRFLOW (CFM)	AVAILABLE EXTERNAL STATIC PRESSURE (IWG)									
	2.2		2.4		2.6		2.8		3.0	
	RPM	BHP ³	RPM	BHP ³	RPM	BHP ³	RPM	BHP ³	RPM	BHP ³
6000	779	5.1	808	5.5	837	6.0	864	6.4	890	6.9
7000	793	6.1	822	6.6	850	7.0	877	7.5	903	8.1
8000	807	7.0	836	7.6	863	8.1	890	8.6	916	9.2
9000	823	8.3	850	8.8	877	9.4	902	10.0	928	10.6
10000	839	9.5	865	10.1	890	10.7	915	11.3	940	12.0
11000	862	11.0	886	11.6	910	12.2	934	12.9	957	13.5
12000	884	12.5	907	13.2	930	13.8	953	14.4	975	15.0
13000	909	14.6	931	15.2	953	15.9	975	16.5	996	17.2
14000	935	16.6	956	17.3	976	18.0	997	18.7	1017	19.4
15000	963	18.9	982	19.6	1002	20.4	1021	21.1	1040	21.8

AIRFLOW (CFM)	AVAILABLE EXTERNAL STATIC PRESSURE (IWG)									
	3.2		3.4		3.6		3.8		4.0	
	RPM	BHP ³	RPM	BHP ³	RPM	BHP ³	RPM	BHP ³	RPM	BHP ³
6000	916	7.4	940	7.9	964	8.3	988	8.8	1011	9.3
7000	928	8.6	953	9.1	977	9.6	1000	10.1	1023	10.7
8000	941	9.8	965	10.3	989	10.9	1013	11.5	1035	12.0
9000	952	11.2	976	11.8	1000	12.4	1023	13.0	1045	13.6
10000	964	12.6	987	13.2	1010	13.9	1033	14.5	1055	15.1
11000	981	14.1	1003	14.8	1025	15.5	1047	16.1	1069	16.8
12000	997	15.7	1019	16.4	1040	17.1	1061	17.8	1082	18.5
13000	1017	17.9	1038	18.6	1058	19.4	1078	20.1	1097	20.8
14000	1037	20.2	1056	20.9	1076	21.6	1094	22.4	1113	23.1
15000	1059	22.6	1078	23.3	1097	24.1	1115	24.9	1134	25.7

1. Fan performance is based on wet evaporator coils, clean 2" throwaway filters and system/cabinet effects at standard air density and 0 feet elevation.

2. Refer to Tables 66, 15, 21 and 39 for component additions and deductions to fan performance tables.

3. BHP includes drive losses.

4. Shaded RPMs require Class II blower.

30 Ton Forward Curve

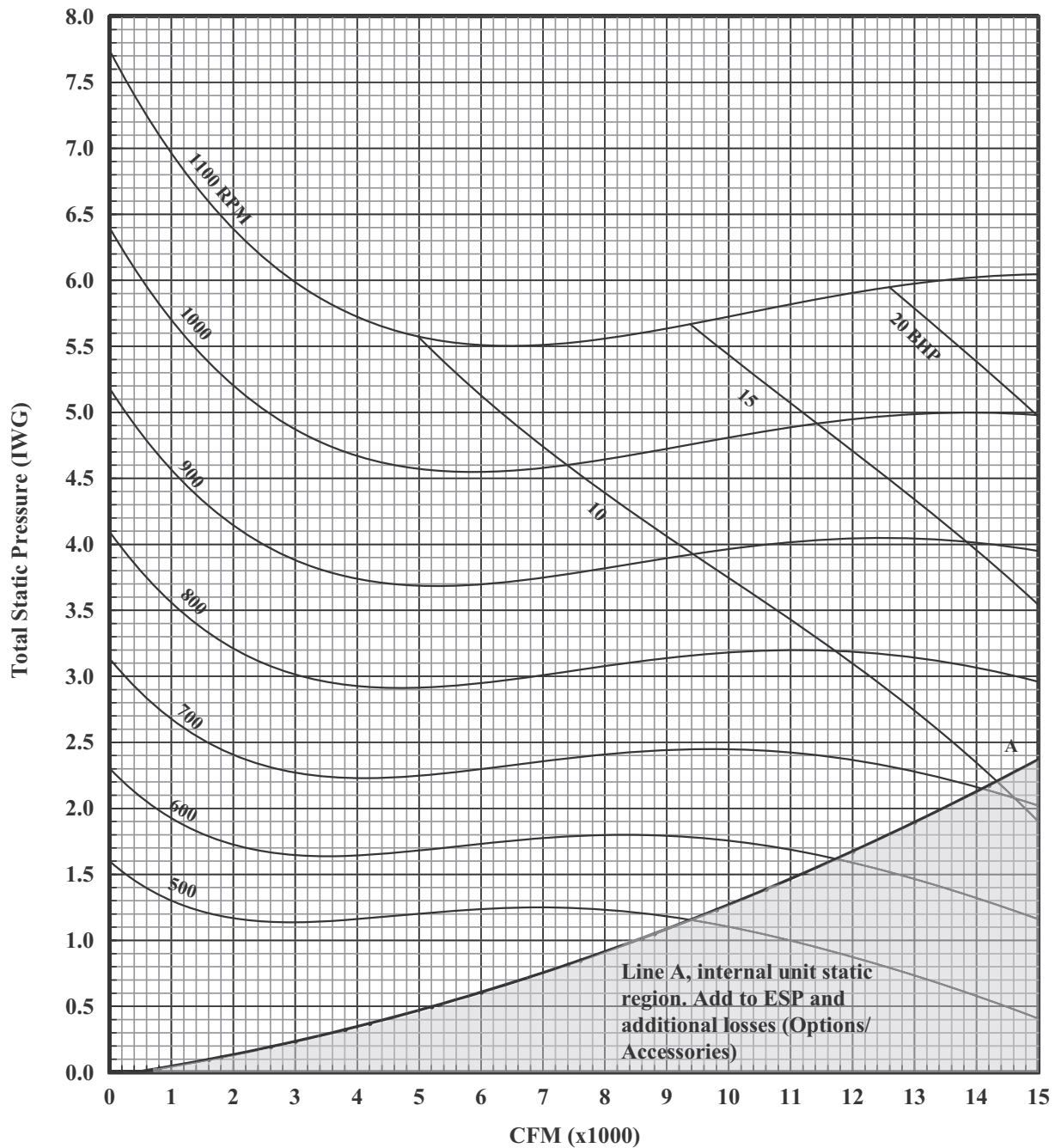

NOTE: All areas below the "A" curve are fixed, internal cabinet losses and should be considered when determining total system static and plotting unit fan performance.

NOTE: Standard Unit includes wet evaporator coil, clean 2" throwaway filters, system and cabinet effects at standard air density and 0' elevation.

FIGURE 27 - FAN PERFORMANCE - 30 TON

TABLE 38: FAN PERFORMANCE - 40 TON^{1,2}

AIRFLOW (CFM)	AVAILABLE EXTERNAL STATIC PRESSURE (IWG)									
	0.2		0.4		0.6		0.8		1.0	
	RPM	BHP ³	RPM	BHP ³	RPM	BHP ³	RPM	BHP ³	RPM	BHP ³
8000	320	1.3	368	1.7	412	2.2	452	2.7	488	3.2
9000	356	1.8	396	2.3	435	2.8	472	3.3	506	3.8
10000	385	2.3	422	2.8	457	3.3	491	3.8	522	4.4
11000	410	3.0	445	3.5	478	4.1	510	4.6	540	5.1
12000	436	3.6	468	4.2	500	4.8	529	5.3	558	5.9
13000	455	4.3	486	4.9	516	5.5	546	6.2	573	6.8
14000	477	5.0	508	5.7	536	6.4	563	7.1	590	7.8
15000	508	6.3	535	7.0	563	7.6	588	8.4	612	9.2
16000	538	7.5	564	8.2	588	9.0	612	9.7	635	10.5
17000	561	9.0	586	9.7	610	10.5	633	11.2	656	12.0
18000	585	10.5	609	11.3	632	12.0	654	12.8	677	13.6

AIRFLOW (CFM)	AVAILABLE EXTERNAL STATIC PRESSURE (IWG)									
	1.2		1.4		1.6		1.8		2.0	
	RPM	BHP ³	RPM	BHP ³	RPM	BHP ³	RPM	BHP ³	RPM	BHP ³
8000	523	3.6	556	4.1	586	4.6	614	5.1	641	5.6
9000	538	4.3	568	4.8	598	5.3	625	5.9	652	6.4
10000	552	4.9	582	5.5	610	6.0	636	6.5	662	7.1
11000	569	5.7	596	6.3	623	6.9	649	7.5	674	8.1
12000	585	6.6	612	7.2	637	7.8	662	8.5	686	9.1
13000	599	7.5	626	8.1	650	8.8	674	9.5	699	10.2
14000	616	8.5	641	9.2	666	9.9	689	10.7	712	11.4
15000	637	9.9	660	10.6	684	11.3	707	12.1	729	12.9
16000	658	11.3	680	12.0	702	12.8	724	13.6	745	14.3
17000	678	12.9	699	13.6	721	14.4	742	15.3	762	16.1
18000	697	14.5	718	15.3	739	16.1	760	16.9	780	17.8

AIRFLOW (CFM)	AVAILABLE EXTERNAL STATIC PRESSURE (IWG)									
	2.2		2.4		2.6		2.8		3.0	
	RPM	BHP ³	RPM	BHP ³	RPM	BHP ³	RPM	BHP ³	RPM	BHP ³
8000	667	6.1	691	6.6	715	7.1	737	7.5	759	8.1
9000	677	6.9	702	7.4	725	8.0	747	8.6	769	9.2
10000	687	7.8	712	8.4	735	9.0	758	9.7	779	10.3
11000	698	8.8	722	9.4	745	10.1	767	10.8	789	11.5
12000	709	9.8	732	10.5	755	11.2	777	11.8	798	12.5
13000	722	10.9	743	11.7	765	12.4	787	13.1	808	13.9
14000	734	12.2	756	12.9	778	13.7	798	14.4	819	15.2
15000	750	13.6	771	14.4	791	15.2	812	16.0	832	16.9
16000	765	15.1	785	15.9	805	16.8	825	17.6	844	18.4
17000	782	16.9	801	17.8	821	18.6	840	19.5	858	20.4
18000	799	18.7	818	19.6	837	20.5	855	21.4	874	22.3

AIRFLOW (CFM)	AVAILABLE EXTERNAL STATIC PRESSURE (IWG)									
	3.2		3.4		3.6		3.8		4.0	
	RPM	BHP ³	RPM	BHP ³	RPM	BHP ³	RPM	BHP ³	RPM	BHP ³
8000	780	8.6	800	9.2	821	9.9	841	10.5	861	11.2
9000	790	9.8	811	10.5	831	11.1	852	11.8	872	12.5
10000	801	11.0	821	11.7	842	12.3	862	12.9	882	13.6
11000	809	12.2	831	12.8	850	13.5	871	14.2	890	14.9
12000	819	13.2	839	14.0	859	14.7	879	15.4	899	16.1
13000	828	14.7	848	15.4	868	16.2	887	17.0	907	17.7
14000	839	16.0	858	16.8	878	17.6	896	18.4	915	19.2
15000	850	17.7	870	18.5	889	19.3	907	20.1	926	21.0
16000	863	19.3	882	20.2	900	21.1	918	22.0	936	22.8
17000	877	21.3	896	22.2	913	23.1	931	23.8	944	24.6
18000	891	23.3	910	24.2	928	25.1	946	26.1	-	-

1. Fan performance is based on wet evaporator coils, clean 2" throwaway filters and system/cabinet effects at standard air density and 0 feet elevation.
2. Refer to Tables 66, 15, 21 and 39 for component additions and deductions to fan performance tables.
3. BHP includes drive losses.
4. Shaded RPMs require Class II blower.

40 Ton Forward Curve

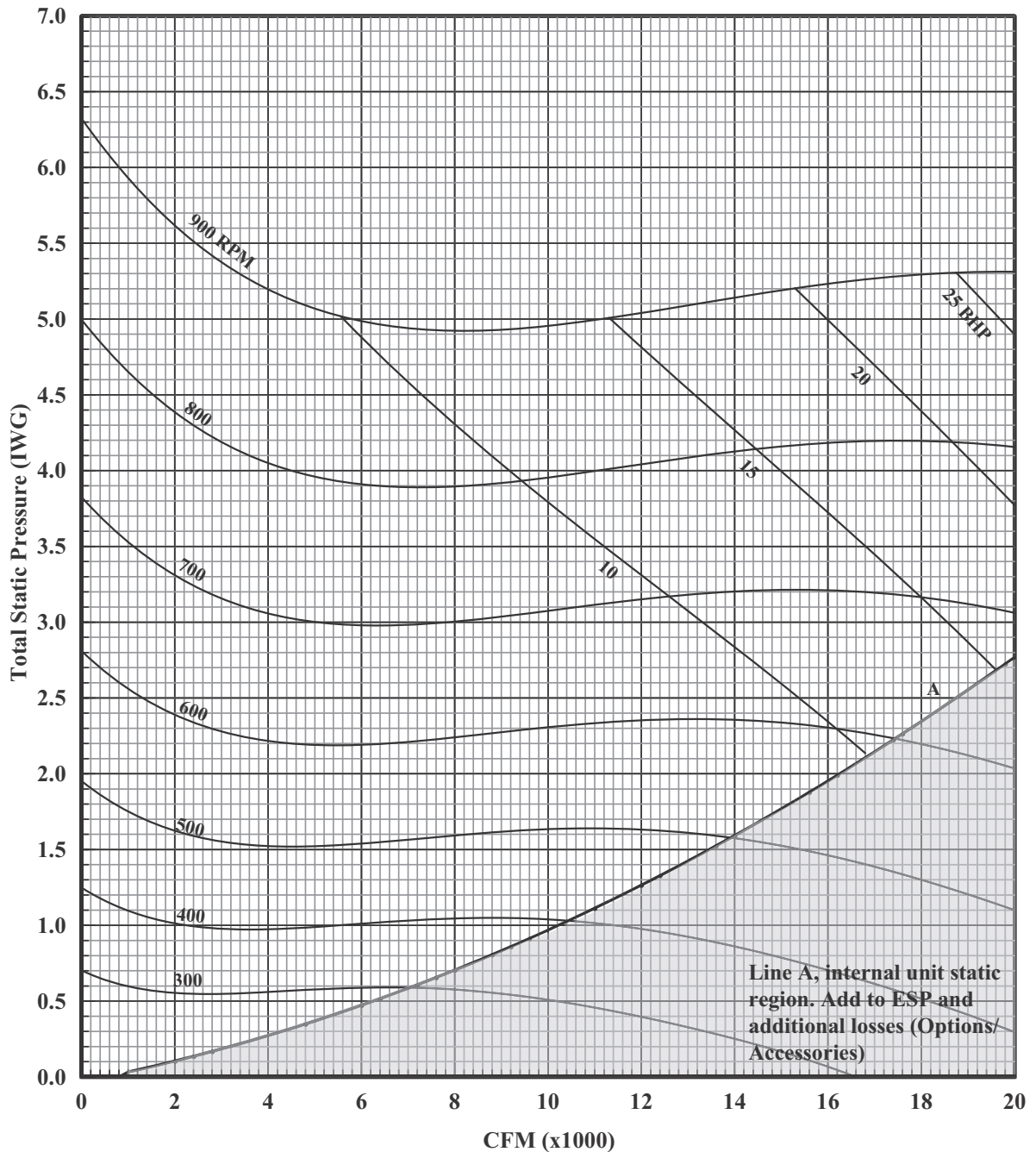

NOTE: All areas below the "A" curve are fixed, internal cabinet losses and should be considered when determining total system static and plotting unit fan performance.

NOTE: Standard Unit includes wet evaporator coil, clean 2" throwaway filters, system and cabinet effects at standard air density and 0' elevation.

FIGURE 28 - FAN PERFORMANCE - 40 TON

TABLE 39: COMPONENT STATIC RESISTANCE^{1, 2}

COMPONENT COIL LOSSES	CFM							
	4,000	6,000	8,000	10,000	12,000	14,000	16,000	18,000
COIL LOSSES 25T								
3 Row, 16 FPI, dry	-0.14	-0.18	-0.24	-0.34	-0.45	-	-	-
3 Row, 16 FPI, wet	Baseline	Baseline	Baseline	Baseline	Baseline	-	-	-
COIL LOSSES 30T								
4 Row, 16 FPI, dry	-0.18	-0.22	-0.32	-0.45	-0.60	-0.76	-	-
4 Row, 16 FPI, wet	Baseline	Baseline	Baseline	Baseline	Baseline	Baseline	-	-
COIL LOSSES 40T								
4 Row, 16 FPI, dry	-0.022	-0.082	-0.123	-0.204	-0.263	-0.391	-0.494	-0.607
4 Row, 16 FPI, wet	Baseline	Baseline	Baseline	Baseline	Baseline	Baseline	Baseline	Baseline
FILTER LOSSES								
2" TA or HI EFF.	Baseline	Baseline	Baseline	Baseline	Baseline	Baseline	Baseline	Baseline
Rigid 6", 65%	0.06	0.12	0.19	0.27	0.36	0.46	0.58	0.70
Rigid 6", 95%	0.13	0.26	0.41	0.60	0.81	1.04	1.29	1.57
IGV LOSSES								
25 & 30 Ton F.C.	0.02	0.05	0.08	0.13	0.19	0.26	0.34	0.43
40 Ton F.C.	0.01	0.03	0.05	0.08	0.11	0.15	0.19	0.25
GAS HEAT								
267 MBH Heat	0.07	0.11	0.14	0.18	0.21	0.25	0.28	0.32
533 MBH Heat	0.14	0.21	0.28	0.35	0.42	0.49	0.57	0.64
800 MBH Heat	0.21	0.32	0.42	0.53	0.64	0.74	0.85	0.95
ELECTRIC HEAT								
40KW	0.01	0.02	0.04	0.06	0.10	0.20	0.31	0.40
80KW	0.01	0.04	0.08	0.13	0.20	0.31	0.44	0.56
108KW	0.02	0.05	0.10	0.15	0.31	0.43	0.53	0.68
ECONOMIZER								
	0.03	0.06	0.10	0.15	0.21	0.28	0.35	0.43
POWER EXHAUST								
	0.02	0.05	0.08	0.13	0.18	0.25	0.32	0.41

1. Baseline losses based on system/cabinet effects, wet standard coil and 2" throwaway filters at 70°F, 0 feet elevation with standard air.

2. See Tables 66, 67, 15, 18 and 21 for hot water and steam water coil static resistance.

TABLE 40: SUPPLY FAN MOTOR AND DRIVE DATA

Model	Blower RPM Range	Motor				Motor Pulley		Blower Pulley		Belts	
		HP	Frame Size	Motor Efficiency (Std. Motor)	Motor Efficiency (Ultra Hi Eff Opt)	Pitch Dia (Inches)	Bore (Inches)	Pitch Dia (Inches)	Bore (Inches)	Designation	Qty
25 Ton	567	7.5	213T	88.5	91.7	4.5	1-3/8	13.9	2-3/16	BX56	2
	692	10	215T	89.5	91	5.5	1-3/8	13.9	2-3/16	BX56	2
	793	15	254T	91	91.7	6.3	1-5/8	13.9	2-3/16	BX56	2
	894	20	256T	91	93	7.1	1-5/8	13.9	2-3/16	BX56	2
30 Ton	617	10	215T	89.5	91	4.9	1-3/8	13.9	2-3/16	BX56	2
	743	15	254T	91	91.7	5.9	1-5/8	13.9	2-3/16	BX56	2
	856	20	256T	91	93	6.7	1-5/8	13.7	2-3/16	5VX610	2
	907	25	284T	91.7	93.6	7.1	1-7/8	13.7	2-3/16	5VX610	2
40 Ton	617	10	215T	89.5	91	4.9	1-3/8	13.9	2-7/16	BX67	2
	652	15	254T	91	91.7	5.1	1-5/8	13.7	2-7/16	5VX710	2
	728	20	256T	91	93	5.7	1-5/8	13.7	2-7/16	5VX710	2
	780	25	284T	91.7	93.6	6.1	1-7/8	13.7	2-7/16	5VX710	2

TABLE 41: EXHAUST FAN DRIVE DATA

Model	Blower RPM Range	Motor				Motor Pulley		Blower Pulley		Belts	
		HP	Frame Size	Motor Eff (Std. Motor)	Motor Eff (Hi Eff opt)	Pitch Dia (Inches)	Bore (Inches)	Pitch Dia (Inches)	Bore (Inches)	Designation	Qty
25 Ton	758	5	213T	87.5	89.5	4.9	1-3/8	11.3	2-3/16	BX63	2
	852	7.5	215T	88.5	91.7	5.5	1-3/8	11.3	2-3/16	BX63	2
	976	10	215T	89.5	91	6.3	1-5/8	11.3	2-3/16	BX63	2
30 Ton	852	7.5	213T	84	86.5	5.5	1-3/8	11.3	1-11/16	B65	2
	976	10	215T	86.5	89.5	6.3	1-3/8	11.3	1-11/16	B65	2
	1069	15	254T	85.7	89.5	6.9	1-3/8	11.3	1-11/16	B65	2
40 Ton	852	7.5	184T	84	86.5	5.5	1-3/8	11.3	1-11/16	B65	2
	976	10	215T	86.5	89.5	6.3	1-3/8	11.3	1-11/16	B65	2
	1069	15	254T	85.7	89.5	6.9	1-3/8	11.3	1-11/16	B65	2

TABLE 42: POWER EXHAUST - ONE FORWARD CURVED FAN 25 TON¹

AIRFLOW CFM	AVAILABLE EXTERNAL STATIC PRESSURE (IWG)									
	0.2		0.4		0.6		0.8		1.0	
	RPM	BHP ²	RPM	BHP ²	RPM	BHP ²	RPM	BHP ²	RPM	BHP ²
2000	---	---	---	---	524	0.3	609	0.4	685	0.6
3000	---	---	450	0.4	531	0.5	605	0.7	672	0.8
4000	442	0.7	496	0.8	562	0.9	626	1.1	687	1.2
5000	524	1.2	566	1.4	609	1.5	663	1.7	717	1.8
6000	612	1.9	646	2.2	679	2.4	717	2.6	762	2.7
7000	703	3.0	731	3.3	759	3.5	787	3.7	820	4.0
8000	791	3.8	821	4.3	844	4.8	868	5.2	892	5.5
9000	877	5.8	911	6.2	932	6.5	953	6.9	974	7.3
10000	967	8.4	1004	8.8	1022	9.1	1041	9.4	1059	9.8

AIRFLOW CFM	AVAILABLE EXTERNAL STATIC PRESSURE (IWG)									
	1.2		1.4		1.6		1.8		2.0	
	RPM	BHP ²	RPM	BHP ²	RPM	BHP ²	RPM	BHP ²	RPM	BHP ²
2000	754	0.7	819	0.8	878	0.9	933	1.1	986	1.2
3000	736	1.0	797	1.1	854	1.3	909	1.5	961	1.7
4000	743	1.4	799	1.5	850	1.7	900	1.9	948	2.1
5000	768	2.0	818	2.2	865	2.4	911	2.6	955	2.8
6000	806	2.9	850	3.1	895	3.3	937	3.6	978	3.8
7000	857	4.2	895	4.4	933	4.6	972	4.8	1010	5.0
8000	921	5.7	953	6.0	985	6.2	1018	6.5	1052	6.8
9000	995	7.6	1020	8.0	1048	8.3	1075	8.5	1103	8.8
10000	1077	10.1	1096	10.4	1119	10.8	1143	11.1	1167	11.4

1. Fan performance is based on system/cabinet effects and back draft damper effects at standard air density and 0 feet of elevation.
2. BHP includes 5% drive losses.

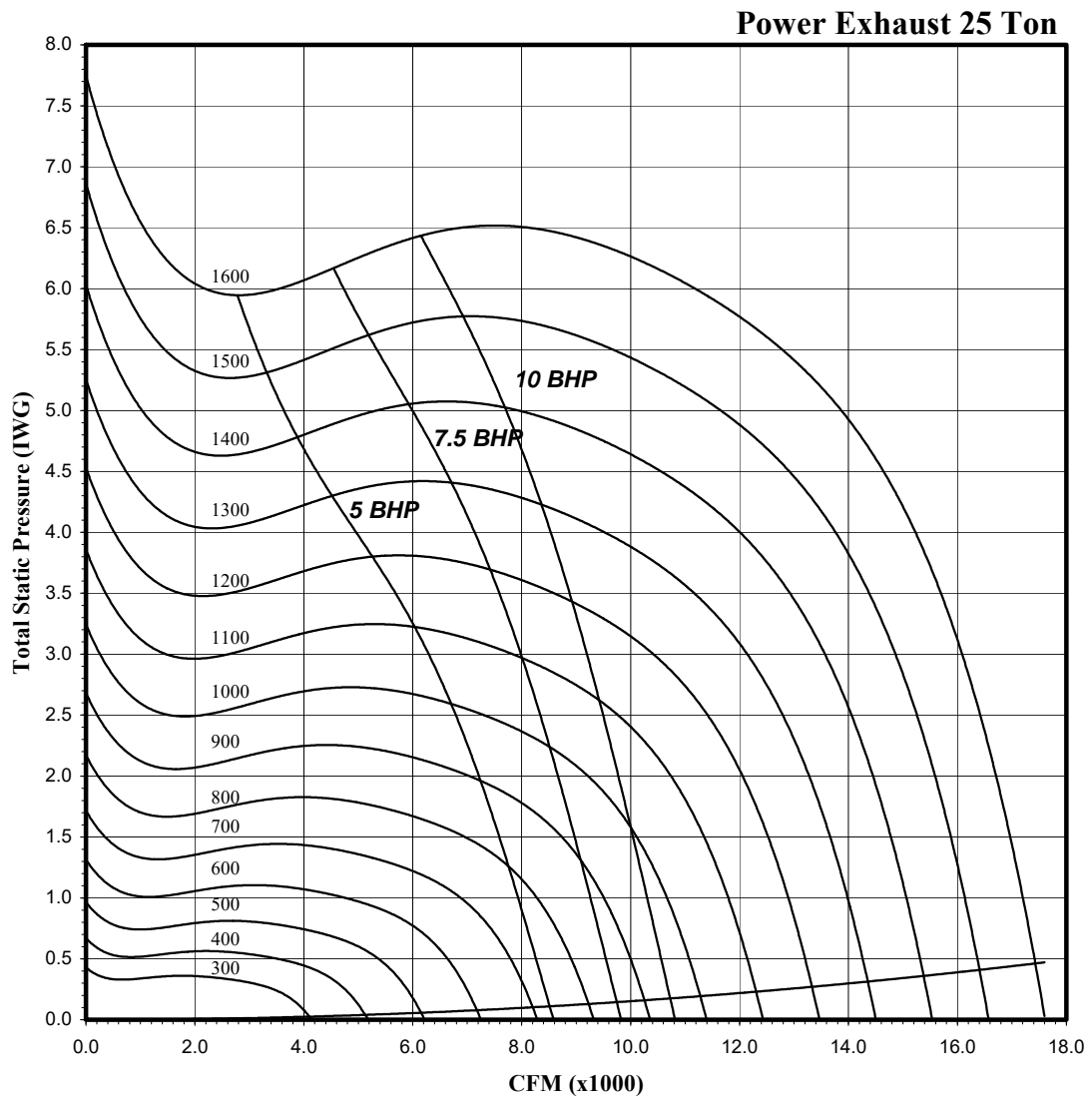

FIGURE 29 - POWER EXHAUST - ONE FORWARD CURVE FAN - 25 TONS

TABLE 43: POWER EXHAUST - TWO FORWARD CURVED FANS - 30 & 40 TON¹

AIRFLOW CFM	AVAILABLE EXTERNAL STATIC PRESSURE (IWG)									
	0.2		0.4		.06		0.8		1.0	
	RPM	BHP ^{2 3}	RPM	BHP ^{2 3}	RPM	BHP ^{2 3}	RPM	BHP ^{2 3}	RPM	BHP ^{2 3}
4000	363	0.32	468	0.53	560	0.74	641	0.95	716	1.16
5000	402	0.53	494	0.74	576	1.05	652	1.26	722	1.47
6000	445	0.84	527	1.05	602	1.37	670	1.68	735	2.00
7000	494	1.26	565	1.58	633	1.79	697	2.10	757	2.52
8000	544	1.79	609	2.10	670	2.42	729	2.73	784	3.15
9000	597	2.42	654	2.84	711	3.15	765	3.47	817	3.89
10000	651	3.26	703	3.68	754	3.99	805	4.41	853	4.83
11000	705	4.31	753	4.73	801	5.15	847	5.57	893	5.99
12000	761	5.46	805	5.88	849	6.30	893	6.83	934	7.25
13000	817	6.93	858	7.35	899	7.77	939	8.30	979	8.82
14000	874	8.51	912	9.03	950	9.56	988	9.98	1025	10.50
15000	932	10.40	967	10.92	1002	11.55	1037	12.08	1072	12.60
16000	989	12.60	1022	13.23	1055	13.76	1088	14.28	-	-

AIRFLOW CFM	AVAILABLE EXTERNAL STATIC PRESSURE (IWG)									
	1.2		1.4		1.6		1.8		2	
	RPM	BHP ^{2 3}	RPM	BHP ^{2 3}	RPM	BHP ^{2 3}	RPM	BHP ^{2 3}	RPM	BHP ^{2 3}
4000	783	1.47	844	1.68	903	1.89	956	2.21	1008	2.42
5000	788	1.79	848	2.10	906	2.42	959	2.63	1011	2.94
6000	798	2.21	855	2.63	911	2.94	963	3.26	1014	3.57
7000	814	2.84	869	3.15	922	3.47	972	3.89	1021	4.20
8000	837	3.47	889	3.89	938	4.20	987	4.62	1033	5.04
9000	866	4.31	915	4.73	961	5.15	1007	5.57	1050	5.99
10000	900	5.25	945	5.67	989	6.20	1032	6.62	1073	7.14
11000	936	6.41	979	6.93	1020	7.35	1061	7.88	1101	8.30
12000	976	7.77	1016	8.30	1055	8.72	1094	9.24	1131	9.77
13000	1018	9.35	1055	9.87	1093	10.40	1129	10.92	1165	11.55
14000	1061	11.13	1098	11.66	1133	12.29	1167	12.92	1202	13.44
15000	1107	13.23	1141	13.76	1175	14.39	1208	14.91	1240	15.54

1. Fan performance is based on system/cabinet effects and back draft damper effects at standard air density and 0 feet elevation.
2. BHP includes the sum of both exhaust fan motors.
3. BHP includes 5% drive losses.

Power Exhaust

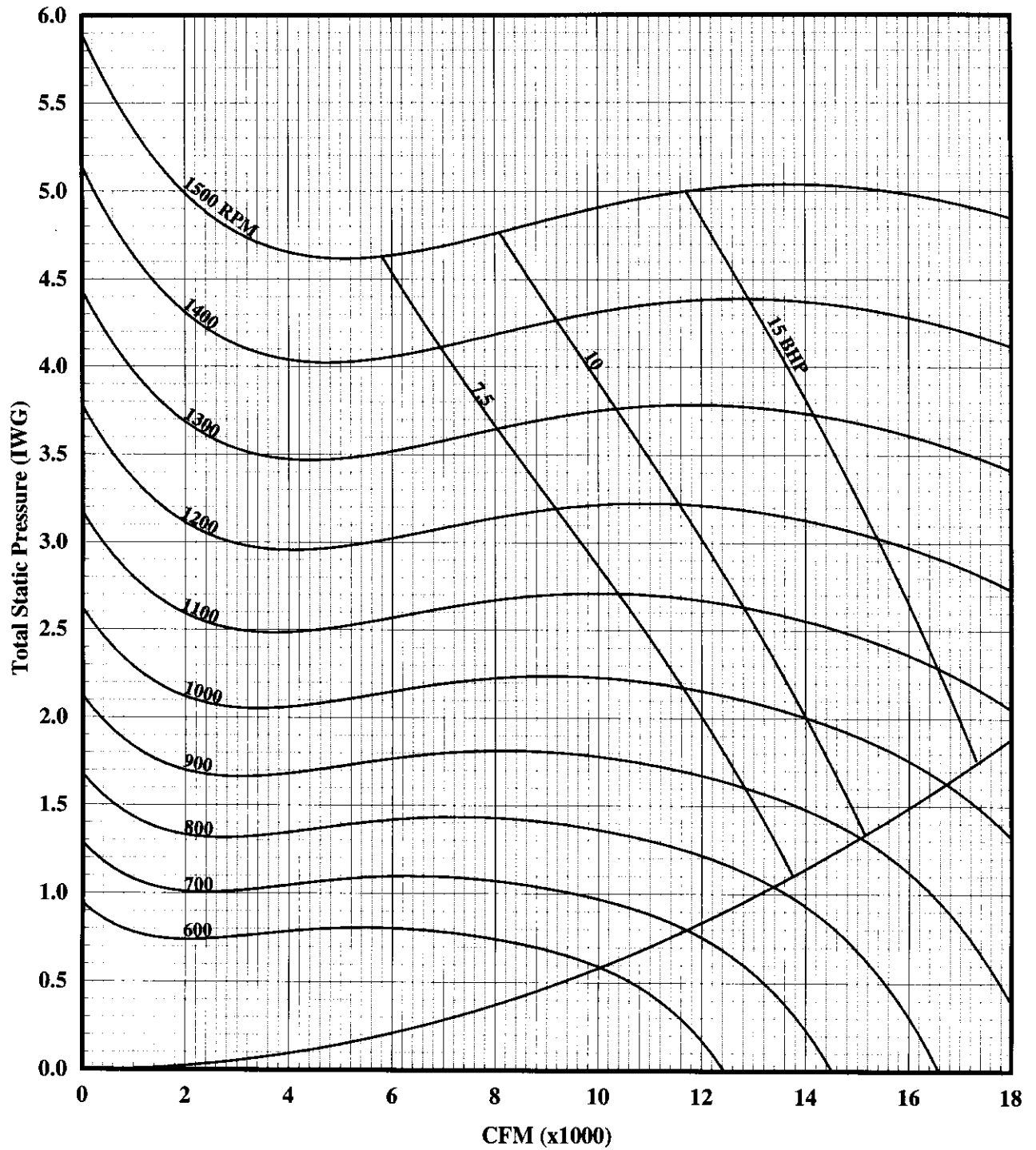

FIGURE 30 - POWER EXHAUST - TWO FORWARD CURVED FANS - 30 & 40 TONS

START-UP

COMPRESSOR ROTATION

Check for proper compressor rotation (See page 81 for symptoms of reverse compressor operations). Millennium units are properly phased at the factory. If the blower, condenser fan, or compressor, rotate in the wrong direction at start-up, the electrical connection to the unit is misphased. Change the incoming line connection phasing to obtain proper rotation.

CAUTION

Scroll compressors require proper rotation to operate correctly. Units are properly phased at the factory. DO NOT change the internal wiring to make the blower, condenser fans or compressor rotate correctly.

SUPPLY AIR FAN INSTRUCTIONS

CHECK BLOWER BEARING SET SCREWS

- The bearing set screws on the supply air blower are properly torqued before shipment. However, in transit they may loosen. Prior to start up they should be rechecked. The set screws are 3/8" and the torque range is 200 - 215 in.-lbs.

NOTE: If a unit is equipped with exhaust fans, those bearing set screws should also be rechecked. The set screws are 1/4 inch and the torque range is 70 - 87 in.-lbs.

CHECKING SUPPLY AIR CFM

The RPM of the supply air blower will depend on the required CFM, the static pressure resistances of the unit components (Tables 39, 57, 58, 66, and 67) and the static pressure resistances of both the supply and the return air duct systems. With this information, the RPM for the supply air blower can be determined from the blower performance data in Tables 36, 37, and 38. See Table 40 for pulley and drive information for the fixed pitch pulleys supplied on the unit.

The supply air CFM must be within the limitations shown in Table 2, and Class II fans must be specified where conditions exceed the rpm limitations of Class I.

NOTE: If unit is equipped with power exhaust fans or return air fan see Tables 42 and 43 for fan performance and for pulley and drive information see Table 41.

FAN ROTATION

Check for proper supply air blower rotation. If fans are rotating backwards the line voltage to unit point of power connection is misphased (see Compressor Rotation above.) If the condenser fans are rotating in the correct direction and the supply fan is not, it will be necessary to switch leads on the

output side of the VFD, since changing phase on the input side of a VFD does not change rotation on the output side. If the VFD is equipped with a bypass, verify that rotation is correct in the bypass mode.

NOTE: If unit is equipped with power exhaust fans or return air fan also check them for proper rotation.

VFD units with bypass must not have the bypass activated unless all individual space dampers are full open. It is the responsibility of the installer to interconnect the bypass mode to the signal to open all boxes on the circuit.

BELT TENSION

The tension on the belt should be adjusted as shown in Figure 31 and Table 44.

NOTE: If unit is equipped with power exhaust fans or return air fan check belt tension and adjust as necessary.

CAUTION

PROCEDURE FOR ADJUSTING BELT TENSION

- Loosen four bolts holding motor base to channels
- Adjust belt by turning nuts "A" (see detail "B").
- Using a belt tension checker, apply a perpendicular force to one belt at the midpoint of the span as shown. The deflection force should be applied until a specific deflection distance of 1/64" per inch of span length is obtained.
- To determine the deflection distance from normal position, use a straight edge from sheave to sheave as a reference line. Use the recommended deflection force per Belt Adjustment Table.

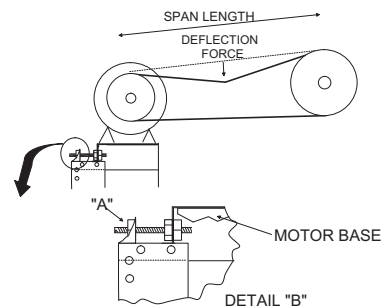

Tension new belts at the maximum deflection force recommended. Check the belt tension at least two times during the first 24 hrs. of operation. Any re-tensioning should fall between the min. and max. deflection force values.

- After adjusting, retighten bolts holding motor base to channel.

FIGURE 31 - BELT TENSION ADJUSTMENT

AIR BALANCE

Start the supply air blower motor. Adjust the resistances in both the supply and the return air duct systems to balance the air distribution throughout the conditioned space. The job specifications may require that this balancing be done by someone other than the equipment installer.

CHECKING AIR QUANTITY



 CAUTION
On VAV and VFD units be certain all IGV's on VAV unit are full open, VFD drive is set to maximum output, exhaust dampers are closed and individual space damper boxes are full open.
VFD units with bypass must not have the bypass activated unless all individual space dampers are full open.

TABLE 44: BELT ADJUSTMENT

FAN MOTOR HORSE POWER	5	7.5	10	15	20	25
30 TON FORWARD CURVED SUPPLY FAN	SIZE: 22 X 20					
Belt Deflection Force (lbs) new belts	-	-	10.5	12.6	15.2	22.1
Belt Deflection Force (lbs) old belts	-	-	7.1	8.5	10.2	14.8
40 TON FORWARD CURVED SUPPLY FAN	SIZE: 25 X 20					
Belt Deflection Force (lbs) new belts	-	-	10.5	12.6	15.2	15.2
Belt Deflection Force (lbs) old belts	-	-	7.1	8.5	10.2	10.2
30 & 40 TON POWER EXHAUST FAN	SIZE: (2) 15 X 15					
Belt Deflection Force (lbs) new belts	-	7.9	9.4	9.4	-	-
Belt Deflection Force (lbs) old belts	-	5.3	6.3	6.3	-	-
25 TON FORWARD CURVE SUPPLY FAN	SIZE: 22 X 20					
New Belt	-	10.5	10.5	12.6	15.2	-
Old Belt	-	7.1	7.1	8.5	10.2	-
25 TON POWER EXHAUST						
New Belt	10.5	10.5	12.6	-	-	-
Old Belt	7.1	7.1	8.5	-	-	-

1. Remove the dot plugs from the two 5/16 inch holes in the blower motor and the filter access doors.
2. Insert at least 8 inch of 1/4 inch metal tubing into each of these holes for sufficient penetration into the air flow on both sides of the indoor coil.
3. Using an inclined manometer or other high resolution pressure measurement device, determine the pressure drop across a dry evaporator coil. Since the moisture on an evaporator coil may vary greatly, measuring the pressure drop across a wet coil under field conditions would be inaccurate. To assure a dry coil, the compressors should be de-activated while the test is being run.
4. Knowing the pressure drop across a dry coil, the actual CFM through the unit with clean 2 inch filters, can be determined from the curve in Figure 60 and 61.

NOTE: De-energize the compressors before taking any test measurements to assure a dry evaporator coil.

 WARNING
Failure to properly adjust the total system air quantity can result in extensive blower or duct damage.

After readings have been obtained, remove the tubes and reinstall the two 5/16 inch dot plugs.

It is especially important to limit the rpm of the fan in VFD-bypass-equipped units; it may be tempting to set max rpm in the VFD to less than 60 Hz - but the bypass will go to 60 Hz immediately on activation.

SUPPLY AIR DRIVE ADJUSTMENT**CAUTION**

Before making any blower speed changes review the installation for any installation errors, leaks or undesirable systems effects that can result in loss of air flow.

Even small changes in blower speed can result in substantial changes in static pressure and BHP. BHP or AMP draw of the blower motor will increase (see Table 45) by the cube ratio of the blower speed. Static pressure will increase by the square ratio of the blower speed. Tables 46, 47 and 48 are for reference only. All blower speed changes must be made by qualified personnel with strict adherence to the fan laws.

At unit start-up the measured CFM based on Figures 60 and 61 may be higher or lower than the specified CFM. To achieve the specified CFM, the speed of the drive may have to be decreased or increased by changing the pitch diameter (PD) of the motor sheave as outlined below:

- $(\text{Specified CFM}/\text{Measured CFM}) \times \text{PD of standard sheave} = \text{PD of new sheave}$.

Use the following tables and the PD calculated per the above equation to select a new motor sheave.

EXAMPLE

- A 30 ton unit was selected to deliver 12,000 CFM with a 20 HP motor and a 856 RPM drive, but the unit is only delivering 11,000 CFM per Figure 25.
- Use the equation to determine the required PD for the new motor sheave $(12,000 \text{ CFM}/11,000 \text{ CFM} \times 6.7" = 7.3091 \text{ inch})$.
- Use the 30 ton table to select a Browning 2B5V74 which will increase the speed of the unit's drive and its supply air CFM to 111.9%. Thus select the 7.5" PD at 112% increase over standard.

- New drive speed = $1.1194 \times 856 = 958.2 \text{ RPM}$
- New supply air = $1.1194 \times 11,000 = 12,313 \text{ CFM}$
- Re-use the existing belts and blower sheave.

New motor BHP = $(\text{speed increase})^3 \times \text{estimated motor BHP at original start-up with 11,000 CFM and 856 RPM} = (1.119)^3 \times 11 \text{ BHP} = 1.4012 \times 11 \text{ BHP} = 15.41 \text{ BHP}$
New motor amps = $(\text{speed increase})^3 \times \text{measured motor amps at original start-up with 11,000 CFM and 856 RPM}$.

TABLE 45: BLOWER SPEED RATE OF CHANGE

CHANGE IN RPM	CHANGE IN		
	CFM	TSP	BHP AND MOTOR AMPS
.90	.90	.81	.73
.93	.93	.86	.79
.95	.95	.90	.86
.98	.98	.95	.93
1.00	1.00	1.00	1.00
1.03	1.03	1.05	1.08
1.05	1.05	1.10	1.16
1.08	1.08	1.16	1.24
1.10	1.10	1.21	1.33
1.13	1.13	1.27	1.42
1.15	1.15	1.32	1.52
1.18	1.18	1.38	1.62
1.20	1.20	1.44	1.73

SYSTEM SETPOINTS**Constant Volume and Variable Air Volume:**

Thermostat and space sensor offsets must be made external to the unit. For internal settings, refer to the Settable Parameters in the Unit Control document. All parameters affecting the unit with that specific set of options and for that specific application must be reviewed. In many cases, the default settings will be fine - but verify and fine tune where necessary.

TABLE 46: 25 TON DRIVE ADJUSTMENT FOR CONSTANT VOLUME & VAV UNITS CLASS 1 & 2 FC FAN

7.5 HP MOTOR & 567 RPM DRIVE			10 HP MOTOR & 692 RPM DRIVE			15 HP MOTOR & 793 RPM DRIVE			20 HP MOTOR & 894 RPM DRIVE		
%RPM & CFM	REQ'D PD	BROWNING 2B5V__	%RPM & CFM	REQ'D PD	BROWNING 2B5V__	%RPM & CFM	REQ'D PD	BROWNING 2B5V__	%RPM & CFM	REQ'D PD	BROWNING 2B5V__
-	-	-	82	4.5	42	84	5.3	50	86	6.1	58
-	-	-	86	4.7	44	87	5.5	52	89	6.3	60
100	(Std.) 4.5 ¹	42	89	4.9	46	90	5.7	54	91	6.5	62
104	4.7	44	93	5.1	48	94	5.9	56	94	6.7	64
109	4.9	46	96	5.3	50	97	6.1	58	97	6.9	66
113	5.1	48	100	(Std.) 5.5 ¹	52	100	(Std.) 6.3 ¹	60	100	(Std.) 7.1 ¹	68
118	5.3	50	104	5.7	54	103	6.5	62	103	7.3	70
122	5.5	52	107	5.9	56	106	6.7	64	108	7.7	74
126	5.7	54	111	6.1	58	110	6.9	66	117	8.3	80
-	-	-	115	6.3	60	113	7.1	68	125	8.9	86
-	-	-	118	6.5	62	116	7.3	70	-	-	-
-	-	-	122	6.7	64	122	7.7	74	-	-	-

1. (Std), Standard Factory Supplied Drive. All other drive combinations must be purchased and field installed.

TABLE 47: 30 TON DRIVE ADJUSTMENT FOR CONSTANT VOLUME & VAV UNITS CLASS 1 & 2 FC FAN

10 HP MOTOR & 617 RPM DRIVE			15 HP MOTOR & 743 RPM DRIVE			20 HP MOTOR & 856 RPM DRIVE			25 HP MOTOR & 907 RPM DRIVE		
%RPM & CFM	REQ'D PD	BROWNING 2B5V__	%RPM & CFM	REQ'D PD	BROWNING 2B5V__	%RPM & CFM	REQ'D PD	BROWNING 2B5V__	%RPM & CFM	REQ'D PD	BROWNING 2B5V__
91.8	4.5	42	86.4	5.1	48	82.1	5.5	54	86.3	6.1	60
95.9	4.7	44	89.8	5.3	50	85.1	5.7	56	89.0	6.3	62
100.0	(Std.) 4.9 ¹	46	93.2	5.5	52	88.1	5.9	58	91.8	6.5	64
104.1	5.1	48	96.6	5.7	54	91.0	6.1	60	94.5	6.7	66
108.2	5.3	50	100.0	(Std.) 5.9 ¹	56	94.0	6.3	62	97.3	6.9	68
112.2	5.5	52	103.4	6.1	58	97.0	6.5	64	100.0	(Std.) 7.1 ¹	70
116.3	5.7	54	106.8	6.3	60	100.0	(Std.) 6.7 ¹	66	105.5	7.5	74
120.4	5.9	56	110.2	6.5	62	103.0	6.9	68	113.7	8.1	80
124.5	6.1	58	113.6	6.7	64	106.0	7.1	70	121.9	8.7	86
-	-	-	116.9	6.9	66	112.0	7.5	74	-	-	-
-	-	-	120.3	7.1	68	120.9	8.1	80	-	-	-
-	-	-	123.7	7.3	70	129.9	8.7	86	-	-	-

1. (Std), Standard Factory Supplied Drive. All other drive combinations must be purchased and field installed.

TABLE 48: 40 TON DRIVE ADJUSTMENT FOR CONSTANT VOLUME & VAV UNITS CLASS 1 & 2 FC FAN

10 HP MOTOR & 617 RPM DRIVE			15 HP MOTOR & 652 RPM DRIVE			20 HP MOTOR & 728 RPM DRIVE			25 HP MOTOR & 780 RPM DRIVE		
%RPM & CFM	REQ'D PD	BROWNING 2B5V__	% RPM & CFM	REQ'D PD	BROWNING 2B5V__	%RPM & CFM	REQ'D PD	BROWNING 2B5V__	%RPM & CFM	REQ'D PD	BROWNING 2B5V__
91.8	4.5	42	88.2	4.5	44	82.5	4.7	46	83.7	5.1	50
95.9	4.7	44	92.1	4.7	46	86.0	4.9	48	86.9	5.3	52
100.0	(Std.) 4.9 ¹	46	96.0	4.9	48	89.5	5.1	50	90.2	5.5	54
104.1	5.1	48	100.0	(Std.) 5.1 ¹	50	93.0	5.3	52	93.4	5.7	56
108.2	5.3	50	103.9	5.3	52	96.5	5.5	54	96.7	5.9	58
112.2	5.5	52	107.8	5.5	54	100.0	(Std.) 5.7 ¹	56	100.0	(Std.) 6.1 ¹	60
116.3	5.7	54	111.7	5.7	56	103.5	5.9	58	103.3	6.3	62
-	-	-	115.6	5.9	58	107.0	6.1	60	106.6	6.5	64
-	-	-	119.5	6.1	60	110.5	6.3	62	109.8	6.7	66
-	-	-	123.4	6.3	62	114.0	6.5	64	113.1	6.9	68
-	-	-	127.4	6.5	64	117.5	6.7	66	116.4	7.1	70
-	-	-	-	-	66	121.1	6.9	68	119.7	7.5	74

1. (Std), Standard Factory Supplied Drive. All other drive combinations must be purchased and field installed.

TABLE 49: 25 TON DRIVE ADJUSTMENT FOR INTELLISPEED (DISCRETE FAN CONTROL)

Drive, Fan	7.5 HP MOTOR					10 HP MOTOR					15 HP MOTOR					20 HP MOTOR				
	RPM Drive	Blower Sheave 2B5V ¹	Req'd PD	Motor Sheave 2B5V ¹	Req'd PD	RPM Drive	Blower Sheave 2B5V ¹	Req'd PD	Motor Sheave 2B5V ¹	Req'd PD	RPM Drive	Blower Sheave 2B5V ¹	Req'd PD	Motor Sheave 2B5V ¹	Req'd PD	RPM Drive	Blower Sheave 2B5V ¹	Req'd PD	Motor Sheave 2B5V ¹	Req'd PD
FC CL1	555	136	13.6	42	4.2	555	136	13.6	42	4.2	538	154	15.4	46	4.6	538	154	15.4	46	4.6
FC CL2	555	136	13.6	42	4.2	555	136	13.6	42	4.2	538	154	15.4	46	4.6	538	154	15.4	46	4.6
AF	1187	94	9.4	62	6.2	1187	94	9.4	62	6.2	1187	94	9.4	62	6.2	1187	94	9.4	62	6.2

1. All blowers and sheaves are Browning.

TABLE 50: 30 TON DRIVE ADJUSTMENT FOR INTELLISPEED (DISCRETE FAN CONTROL)

Drive, Fan	10 HP MOTOR					15 HP MOTOR					20 HP MOTOR					25 HP MOTOR				
	RPM Drive	Blower Sheave 2B5V ¹	Req'd PD	Motor Sheave ¹	Req'd PD	RPM Drive	Blower Sheave 2B5V ¹	Req'd PD	Motor Sheave ¹	Req'd PD	RPM Drive	Blower Sheave 2B5V ¹	Req'd PD	Motor Sheave ¹	Req'd PD	RPM Drive	Blower Sheave 2B5V ¹	Req'd PD	Motor Sheave 2B5V ¹	Req'd PD
FC CL1	502	136	13.6	2TB38	3.8	502	136	13.6	2TB38	3.8	No option					No option				
FC CL2	502	136	13.6	2TB38	3.8	502	136	13.6	2TB38	3.8	502	136	13.6	2TB38	3.8	538	154	15.4	46	4.6
AF	1240	90	9.0	2B5V62	6.2	1240	90	9.0	2B5V62	6.2	1240	90	9.0	2B5V62	6.2	1240	94	9.0	62	6.2

1. All blowers and sheaves are Browning.

TABLE 51: 40 TON DRIVE ADJUSTMENT FOR INTELLISPEED (DISCRETE FAN CONTROL)

Drive, Fan	10 HP MOTOR					15 HP MOTOR					20 HP MOTOR					25 HP MOTOR				
	RPM Drive	Blower Sheave 2B5V ¹	Req'd PD	Motor Sheave ¹	Req'd PD	RPM Drive	Blower Sheave 2B5V ¹	Req'd PD	Motor Sheave ¹	Req'd PD	RPM Drive	Blower Sheave 2B5V ¹	Req'd PD	Motor Sheave ¹	Req'd PD	RPM Drive	Blower Sheave 2B5V ¹	Req'd PD	Motor Sheave 2B5V ¹	Req'd PD
FC CL1	502	136	13.6	2TB38	3.8	502	136	13.6	2TB38	3.8	502	136	13.6	2TB38	3.8	No option				
FC CL2	502	136	13.6	2TB38	3.8	502	136	13.6	2TB38	3.8	502	136	13.6	2TB38	3.8	538	154	15.4	46	4.6
AF	1187	94	9.4	2B5V62	6.2	1187	94	9.4	2B5V62	6.2	1187	94	9.4	2B5V62	6.2	1187	94	9.4	62	6.2

1. All blowers and sheaves are Browning.

TABLE 52: DRIVE ADJUSTMENT FOR POWER EXHAUST - 25 TON

5 HP Motor & 758 RPM Drive			7.5 HP Motor & 852 RPM Drive			10 HP Motor & 976 RPM Drive		
%RPM & CFM	Req'd PD	Browning 2b5v__	%RPM & CFM	Req'd PD	Browning 2b5v__	%RPM & CFM	Req'd PD	Browning 2b5v__
100	4.9 (Std.) ¹	46	92	5.1	48	93	5.9	56
104	5.1	48	96	5.3	50	97	6.1	58
109	5.3	50	100	5.5 (Std.) ¹	52	100	6.3 (Std.) ¹	60
113	5.5	52	104	5.7	54	103	6.5	62
117	5.7	54	108	5.9	56	107	6.7	64
122	5.9	56	112	6.1	58	110	6.9	66

¹: (Std), Standard Factory Supplied Drive. All other drive combinations must be purchased and field installed.

TABLE 53: DRIVE ADJUSTMENT FOR POWER EXHAUST - 30 & 40 TON

7.5 HP MOTOR & 852 RPM DRIVE			10 HP MOTOR & 976 RPM DRIVE			15 HP MOTOR & 1069 RPM DRIVE		
% RPM & CFM	REQ'D PD (IN)	BROWNING 2B5V__	% RPM & CFM	REQ'D PD (IN)	BROWNING 2B5V__	% RPM & CFM	REQ'D PD (IN)	BROWNING 2B5V__
96.4	5.3	52	93.7	5.9	58	94.2	6.5	64
100.0	(Std.) 5.5 ¹	54	96.8	6.1	60	97.1	6.7	66
103.6	5.7	56	100.0	(Std.) 6.3 ¹	62	100.0	(Std.) 6.9 ¹	68
107.3	5.9	58	103.2	6.5	64	102.9	7.1	70
110.9	6.1	60	106.3	6.7	66	108.7	7.5	74
114.5	6.3	62	109.5	6.9	68	117.4	8.1	80

¹: (Std), Standard Factory Supplied Drive. All other drive combinations must be purchased and field installed.

GAS FURNACE OPERATING INSTRUCTIONS



Each furnace module is equipped with an automatic re-ignition system. DO NOT attempt to manually light the burners.

TO LIGHT THE MAIN BURNERS

1. Turn off electric power to unit.
2. Turn space temperature sensor to lowest setting.
3. Turn gas valve knobs to on position (Refer to Figure 32).
4. Turn on electric power to unit.
5. On Constant Volume units, set space setpoint to warmer or cooler as desired. (If sensor set point temperature is above room temperature, the main burners will ignite). If a second stage of heat is called for, the main burners for second stage heat will ignite for the second stage heat. For VAV units set morning warm-up thermostat far above

the return air temperature and cycle the time clock OFF, then ON.

TO SHUT DOWN

1. Turn off electric power to unit.
2. Depress knob of gas valve while turning to off position or move switch to off position. (Refer to Figure 32).

POST-START CHECKLIST (GAS)

After the entire control circuit has been energized and the heating section is operating, make the following checks:

1. Check for gas leaks in the unit piping as well as the supply piping.
2. Check for correct manifold gas pressures. See Checking Gas Input.
3. Check the supply gas pressure. It must be within the limits shown on rating nameplate. Supply pressure should be checked with all gas appliances in the building at full fire. At no time should the standby gas pressure exceed 13 inches, nor the operating pressure drop below 6 inches. If gas pressure is outside these limits, contact the local gas utility for corrective action.

MANIFOLD GAS PRESSURE ADJUSTMENT

Small adjustments to the gas flow may be made by turning the pressure regulator adjusting screw on the automatic gas valve. Refer to Figure 32.

Adjust as follows:

1. Remove the cap on the regulator. It's located next to the push-on electrical terminals.
2. To decrease the gas pressure, turn the adjusting screw counterclockwise.
3. To increase the gas pressure, turn the adjusting screw clockwise.

NOTE: The factory manifold pressure for each furnace module is 3.50 IWG.

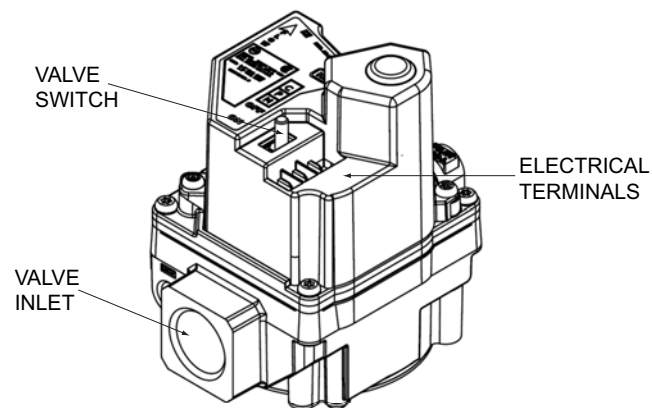

STANDARD GAS VALVE

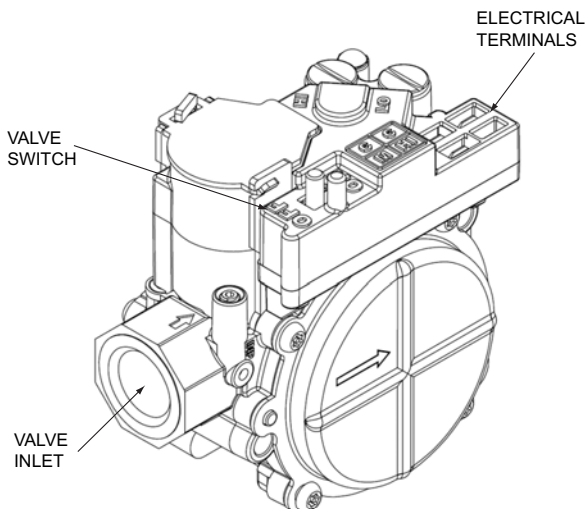

2 STAGE GAS VALVE USED
ON MODULATING GAS HEAT

FIGURE 32 - TYPICAL GAS VALVES

BURNER INSTRUCTIONS

To check or change burners, pilot or orifices, CLOSE MAIN MANUAL SHUT-OFF VALVE AND SHUT OFF ALL POWER TO THE UNIT.

1. Remove the screws holding either end of the manifold to the burner supports.
2. Open the union fitting in the gas supply line just upstream of the unit gas valves and downstream from the main manual shut-off valve.
3. Disconnect wiring to the gas valves and spark ignitors. Remove the manifold-burner gas valve assemblies by pulling back.
4. Remove the heat shield on top of the manifold support.

Burners are now accessible for service.

Reverse the above procedure to replace the assemblies. Make sure that burners are level and seat at the rear of the gas orifice.

ADJUSTMENT OF TEMPERATURE RISE

The temperature rise (or temperature difference between the return air and the heated air from the furnace) must lie within the range shown on the CGA/ETL rating plate and the data in Table 3.

After the temperature rise has been determined, the CFM can be calculated as follows:

$$CFM = \frac{Btuh \times 0.8}{1.08 \times F \text{ Degrees Temp Rise}}$$

After about 20 minutes of operation, determine the furnace temperature rise. Take readings of both the return air and the heated air in the ducts (about six feet from the furnace) where they will not be affected by radiant heat. Increase the blower CFM to decrease the temperature rise; decrease the blower CFM to increase the rise. Refer to Table 40 for supply air blower motor and drive data. Minimum allowable CFM is 6,000 CFM. Limit will open below this rating.

CHECKING GAS INPUT

NATURAL GAS

1. Turn off all other gas appliances connected to the gas meter.
2. With the furnace turned on, measure the time needed for one revolution of the hand on the smallest dial on the meter. A typical gas meter usually has a 1/2 or a 1 cubic foot test dial.

- Using the number of seconds for each revolution and the size of the test dial increment, find the cubic feet of gas consumed per hour from Table 54.

If the actual input is not within 5% of the furnace rating (with allowance being made for the permissible range of the regulator setting), replace the orifice spuds with spuds of the proper size.

NOTE: To find the Btu input, multiply the number of cubic feet of gas consumed per hour by the Btu content of the gas in your particular locality (contact your gas company for this information - it varies widely from city to city).

TABLE 54: GAS RATE - CUBIC FEET PER HOUR

Seconds for One Rev.	Size of Test Dial	
	1/2 cu. Ft.	1 cu. Ft.
2	900	1800
4	450	900
6	300	600
8	225	450
10	180	360

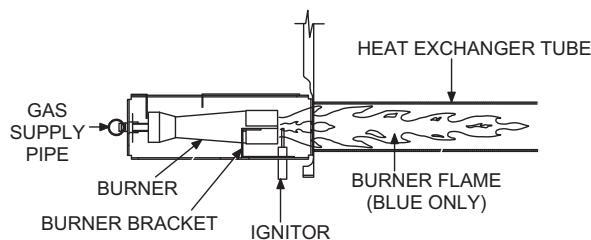

FIGURE 33 - TYPICAL FLAME APPEARANCE

Example: By actual measurement, it takes 7 seconds for the hand on the one cubic foot dial to make a revolution with just a 570,000 Btuh furnace running. Read across to the column in Table 24, headed 1 Cubic Foot where you will determine that 525 cubic feet of gas per hour are consumed by the furnace at that rate. Multiply 525 x 1050 (the Btu rating of the gas obtained from the local gas company). The result of 551,000 Btuh is within 5% of the 570,000 Btuh rating of the furnace.

ELECTRIC HEATING

The electric furnace is operational as shipped from the factory and does not receive any field adjustments.

COOLING OPERATING INSTRUCTIONS

COMPRESSOR

Compressors are factory mounted ready for operation (See page 74 Compressor Rotation).

INTERNAL WIRING

Check all electrical connections in the unit control box; tighten as required.

CONDENSER FANS

Check for proper condenser fan rotation; clockwise facing the air discharge. If condenser fans are rotating backwards, line voltage to unit single point power connection is misphased (See page 74 Compressor Rotation).

SERVICE

REFRIGERATION SYSTEM

CHARGE: Each system is fully factory charged with R-410A. The correct charge appears on the unit nameplate.

Thermal Expansion Valves: The 30 ton unit has 3 and the 40 ton unit has 4 independent refrigeration systems. These TXVs are set to maintain 15°F superheat leaving the evaporator coil. The superheat on each valve is adjustable, however, adjustments should only be made if absolutely necessary.

FILTER DRIER: Each system is equipped with a filter drier. The drier should be replaced whenever moisture is indicated in the system.

COMPRESSORS

Each compressor is inherently protected from over current and over temperature. High and low pressure switches are installed on the discharge and suction lines respectively for high and low pressure protection. Scroll compressors operate in only one direction. If the compressor is experiencing low amperage draw, similar discharge and suction pressure or increased noise level, it is operating in reverse. Switch two line voltage connections to correct (See Compressor Rotation page 74).

MOTORS

INDOOR BLOWER MOTORS

All indoor blower motors are non-inherently protected three phase motors. Overcurrent protection is provided by a manual reset starter/overload relay and short circuit protection is provided by fuses. Where there is a supply fan VFD, an auxiliary contact provides the over-current indication to the Smart Equipment control.

POWER EXHAUST OR RETURN AIR FAN MOTORS

All motors are non-inherently protected three phase motors. Overcurrent protection is provided by a manual reset starter/overload relay and short circuit protection is provided by fuses.

CONDENSER FAN MOTORS

All condenser fan motors are inherently protected three phase motors. Short circuit protection is provided by fuses.

DRAFT MOTOR (GAS FURNACE)

All draft motors are line voltage, inherently protected, single phase PSC motors. Short circuit protection is provided by fuses.

TABLE 55: STEAM COIL (1 ROW, 25 & 30 TON)¹

CFM	Capacity (MBH) at Steam Pressure (PSI)			
	2	6	10	15
6000	194.1	207.9	219.8	232.6
8000	221.1	236.9	250.4	265.0
10000	243.2	260.5	275.4	291.4
12000	261.9	280.6	296.6	313.9
15000	285.6	306.0	323.5	342.4

¹. Based on 60°F entering air temperature, 2.00" maximum air pressure drop across the coil.

TABLE 56: STEAM COIL (1 ROW, 40 TON)¹

CFM	Capacity (MBH) at Steam Pressure (PSI)			
	2	6	10	15
8000	221.1	236.9	250.4	265.0
11000	252.9	271.0	286.4	303.1
14000	278.2	298.0	315.0	333.4
17000	299.4	320.7	339.0	358.8
20000	317.6	340.2	359.6	380.6

¹. Based on 60°F entering air temperature, 2.00" maximum air pressure drop across the coil.

TABLE 57: STATIC RESISTANCE STEAM COIL (25 & 30 TON)

CFM	6000	8000	10000	12000	15000
Air Pressure Drop	0.11	0.18	0.26	0.36	0.54

TABLE 58: STATIC RESISTANCE STEAM COIL (40 TON)

CFM	8000	11000	14000	17000	20000
Air Pressure Drop	0.18	0.31	0.48	0.67	0.88

TABLE 59: HOT WATER COIL (1 ROW 25 & 30 TON)¹

GPM	CFM	Capacity (MBH) at Entering Water Temperature			
		140 °F	160 °F	180 °F	200 °F
10	6000	91.4	115.3	139.3	163.6
	8000	102	128.8	155.8	182.9
	10000	110.4	139.5	168.8	198.4
	12000	117.3	148.4	179.6	211.2
	15000	125.9	159.2	192.9	226.9
20	6000	103	129.4	156	182.7
	8000	116.8	147	177.2	207.7
	10000	128.2	161.3	194.7	228.2
	12000	137.8	173.6	209.5	245.6
	15000	150	189	228.2	267.8
30	6000	107.6	135	162.5	190.1
	8000	122.8	154.3	185.8	217.5
	10000	135.5	170.3	205.1	240.2
	12000	146.4	184	221.8	259.7
	15000	160.3	201.6	243	284.8
40	6000	110.1	138	166	194.1
	8000	126.1	158.2	190.5	222.8
	10000	139.6	175.2	210.9	246.8
	12000	151.2	189.8	228.5	267.5
	15000	166.1	208.6	251.3	294.1

¹. Based on 60°F entering air temperature, 2.00" maximum pressure drop across the hot water coil.

TABLE 60: HOT WATER COIL (1 ROW, 40 TON)¹

GPM	CFM	Capacity (MBH) at Entering Water Temperature			
		140 °F	160 °F	180 °F	200 °F
10	8000	102	128.8	155.8	182.9
	11000	114	144.1	174.4	205.1
	14000	123.2	155.9	188.8	222.1
	17000	130.6	165.4	200.4	235.8
	20000	136.8	173.3	210.1	247.3
20	8000	116.8	147	177.2	207.7
	11000	133.2	167.7	202.3	237.2
	14000	146.2	184.2	222.4	260.8
	17000	157	197.9	239	280.5
	20000	166.2	209.6	253.2	297.3
30	8000	122.8	154.3	185.8	217.5
	11000	141.2	177.4	213.8	250.3
	14000	155.9	196.1	236.4	276.9
	17000	168.3	211.8	255.4	299.3
	20000	179.1	225.3	271.8	318.6
40	8000	126.1	158.2	190.5	222.8
	11000	145.6	182.7	220	257.5
	14000	161.4	202.6	244.1	285.8
	17000	174.7	219.5	264.5	309.7
	20000	186.3	234.2	282.3	330.6

¹. Based on 60°F entering air temperature, 2.00" maximum pressure drop across the hot water coil.

TABLE 61: WATER PRESSURE DROP (1 ROW, 25 & 30 TON)

GPM	10	20	30	40
Water Pressure Drop	0.9	3.0	6.0	10.0

TABLE 62: WATER PRESSURE DROP (1 ROW, 40 TONS)

GPM	10	20	30	40
Water Pressure Drop	0.9	3.0	6.0	10.0

TABLE 63: HOT WATER COIL (2 ROW, 25 & 30 TON)¹

GPM	CFM	Capacity (MBH) at Entering Water Temperature			
		140 °F	160 °F	180 °F	200 °F
20	6000	177.5	223.8	270.4	317.3
	8000	203.8	257.2	311.1	365.5
	10000	224.8	284.1	343.9	404.2
	12000	242.2	306.4	371.1	436.4
	15000	263.6	333.8	404.6	476.1
40	6000	198.1	248.9	300.0	351.3
	8000	232.2	292.0	352.2	412.7
	10000	260.7	328.1	395.9	464.1
	12000	285.0	359.0	433.4	508.3
	15000	316.0	398.4	481.3	564.8
60	6000	206.1	258.7	311.4	364.2
	8000	243.6	305.9	368.4	431.1
	10000	275.3	345.9	416.8	488.0
	12000	302.9	380.7	458.9	537.6
	15000	338.4	425.7	513.4	601.7
80	6000	210.5	263.9	317.4	371.1
	8000	249.8	313.3	377.1	441.1
	10000	283.3	355.6	428.2	501.0
	12000	312.7	392.7	473.0	553.6
	15000	351.0	440.9	531.3	622.1

¹. Based on 60°F entering air temperature, 2.00" maximum pressure drop across the hot water coil.

TABLE 64: WATER PRESSURE DROP (2 ROW, 25 & 30 TON)

GPM	20	40	60	80
Water Pressure Drop	0.9	3.0	6.0	10.0

TABLE 65: WATER PRESSURE DROP (2 ROW, 40 TON)

GPM	20	40	60	80
Water Pressure Drop	0.9	3.0	6.0	10.0

TABLE 66: STATIC RESISTANCE HOT WATER COIL (25 & 30 TON)

CFM	6000	8000	10000	15000
Air Pressure Drop 1 Row	0.07	0.11	0.16	0.32
Air Pressure Drop 2 Row	0.14	0.23	0.33	0.65

TABLE 67: STATIC RESISTANCE HOT WATER COIL (40 TON)

CFM	8000	11000	14000	20000
Air Pressure Drop 1 Row	0.11	0.19	0.29	0.52
Air Pressure Drop 2 Row	0.23	0.39	0.58	1.06

NOTE: Water pressure drop numbers are based on 60°F entering air temperature, 2.00" maximum air pressure drop across the hot water coil(s). AHRI certified ratings at covering other conditions are available upon request. Hot water coils are approved for use with glycol (rates available upon request).

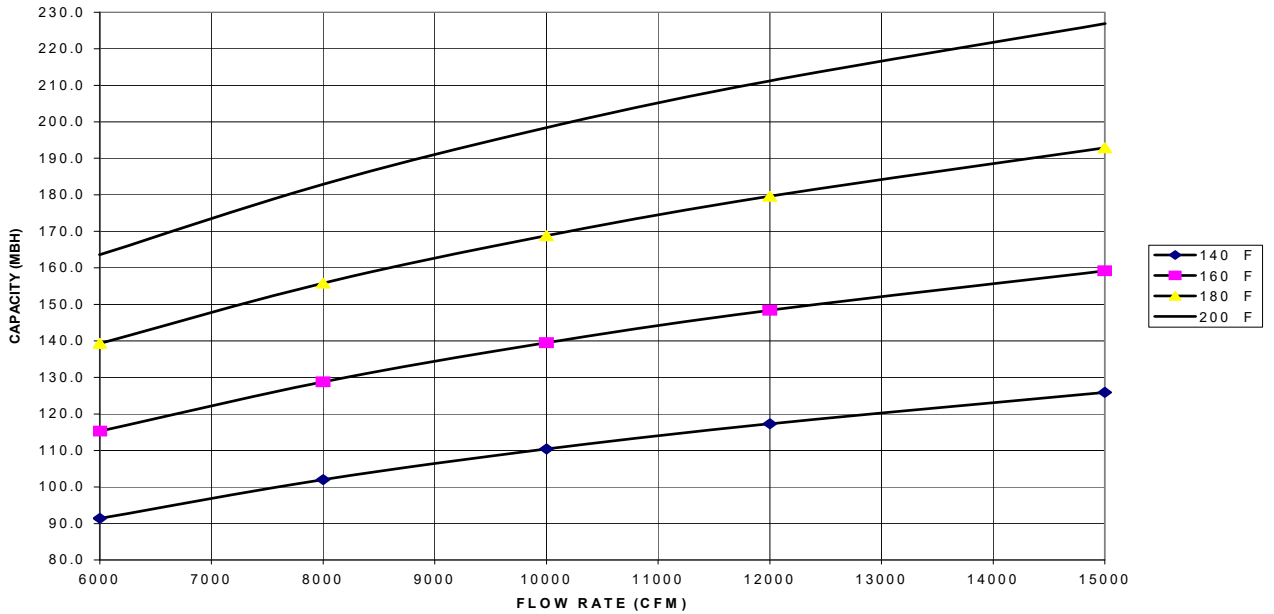

FIGURE 34 - HOT WATER COIL - 25 & 30 TON, 1 ROW, AT 10 GPM

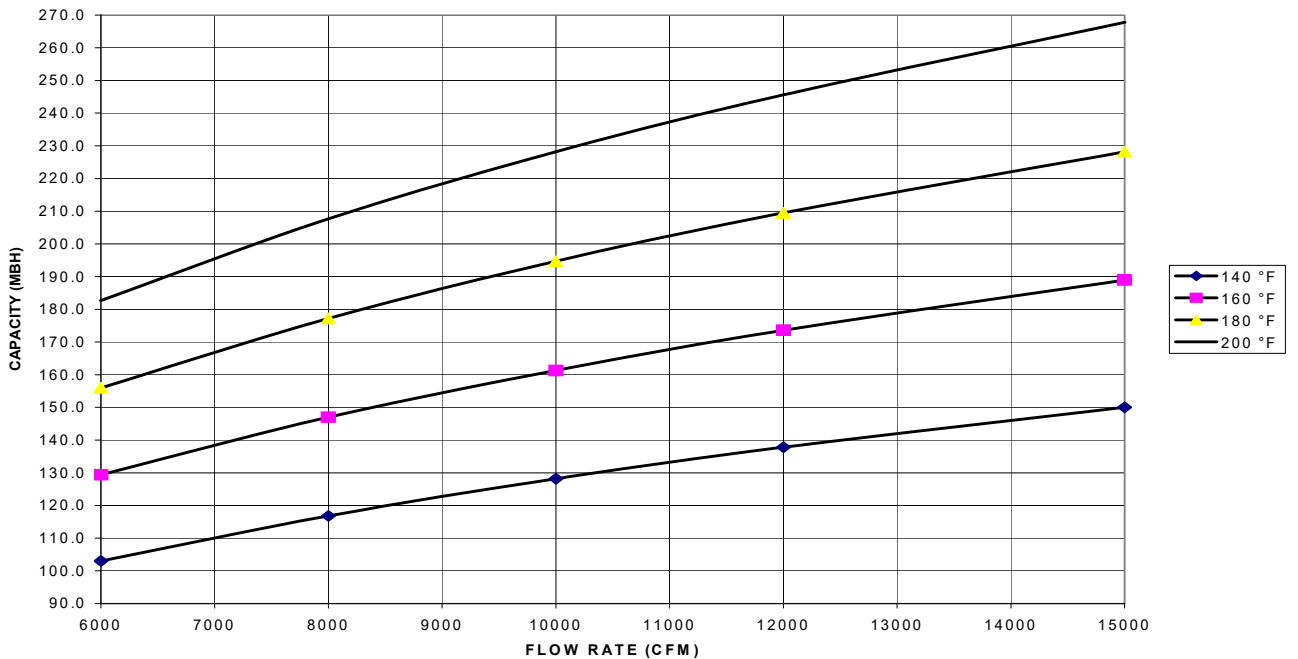

FIGURE 35 - HOT WATER COIL - 25 & 30 TON, 1 ROW, AT 20 GPM

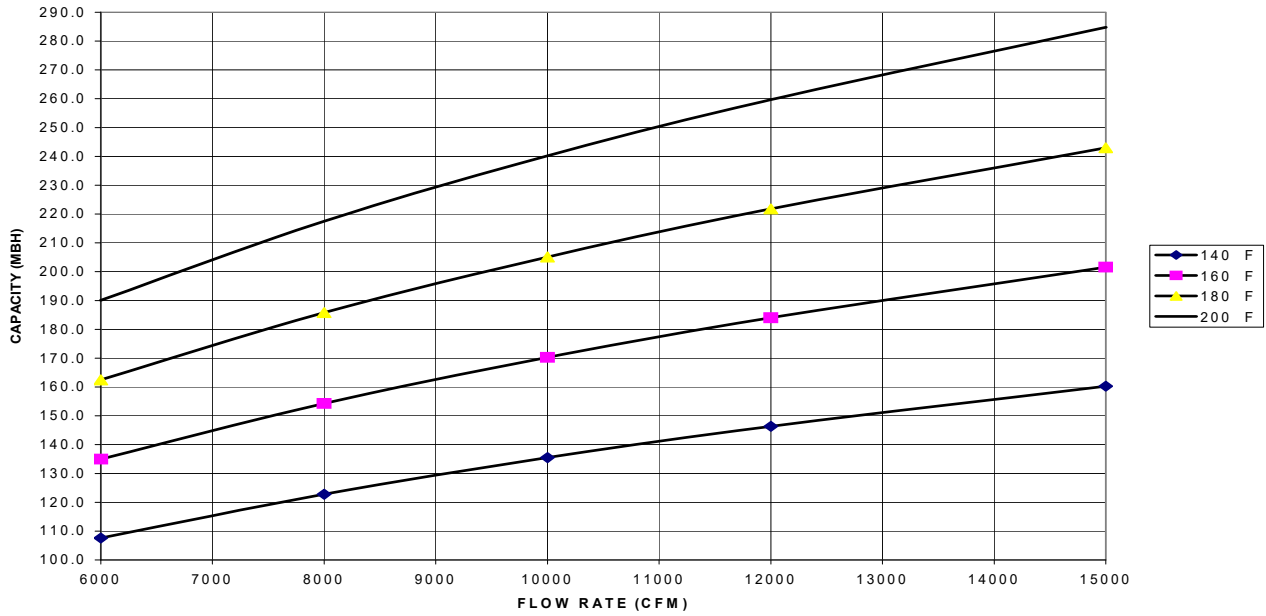

FIGURE 36 - HOT WATER COIL - 25 & 30 TON, 1 ROW, AT 30 GPM

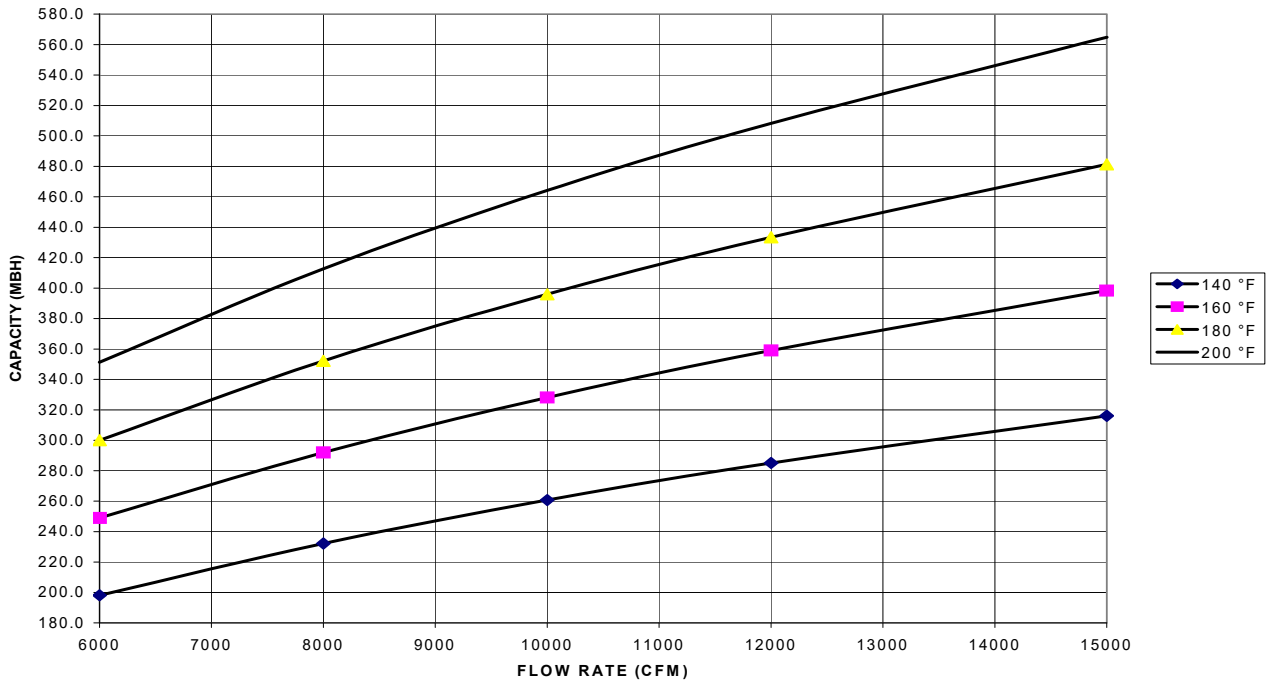

FIGURE 37 - HOT WATER COIL - 25 & 30 TON, 1 ROW, AT 40 GPM

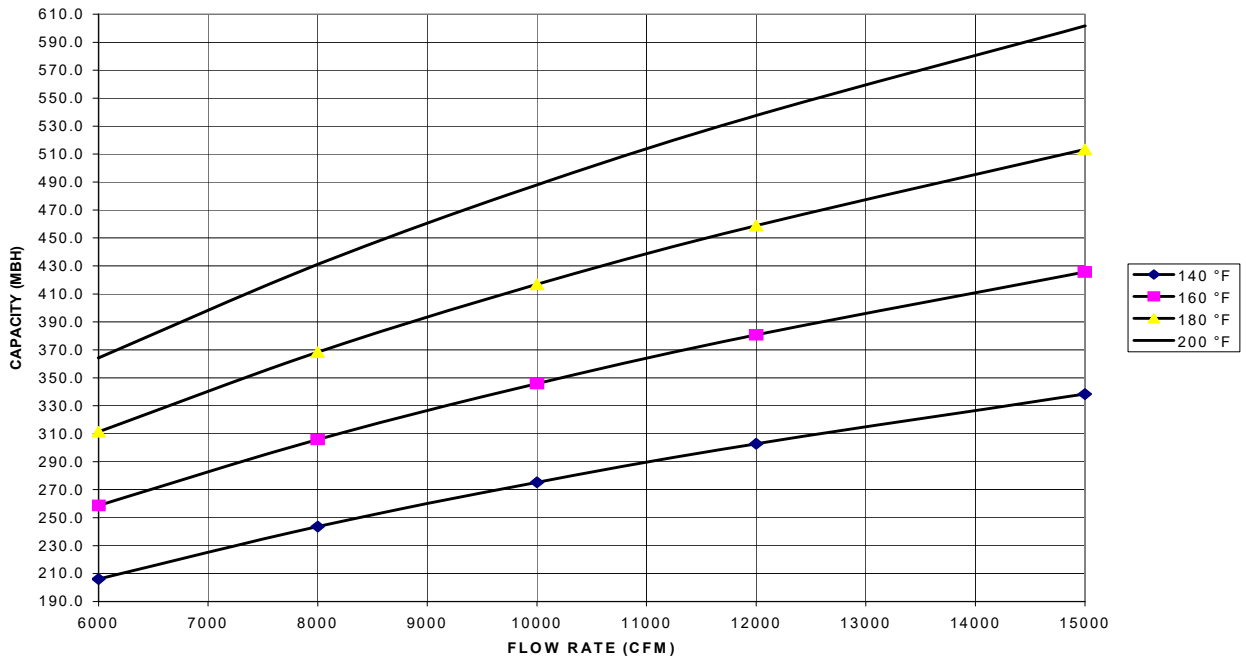

FIGURE 38 - HOT WATER COIL - 25 & 30 TON, 2 ROW, AT 60 GPM

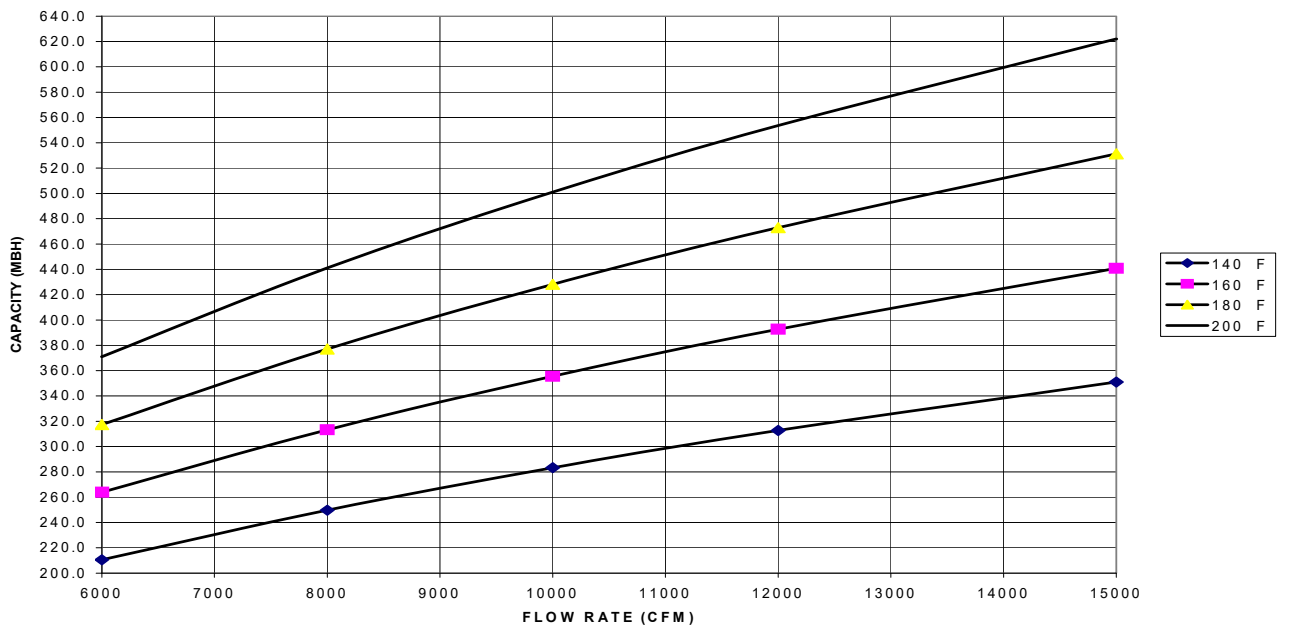

FIGURE 39 - HOT WATER COIL - 25 & 30 TON, 2 ROW, AT 80 GPM

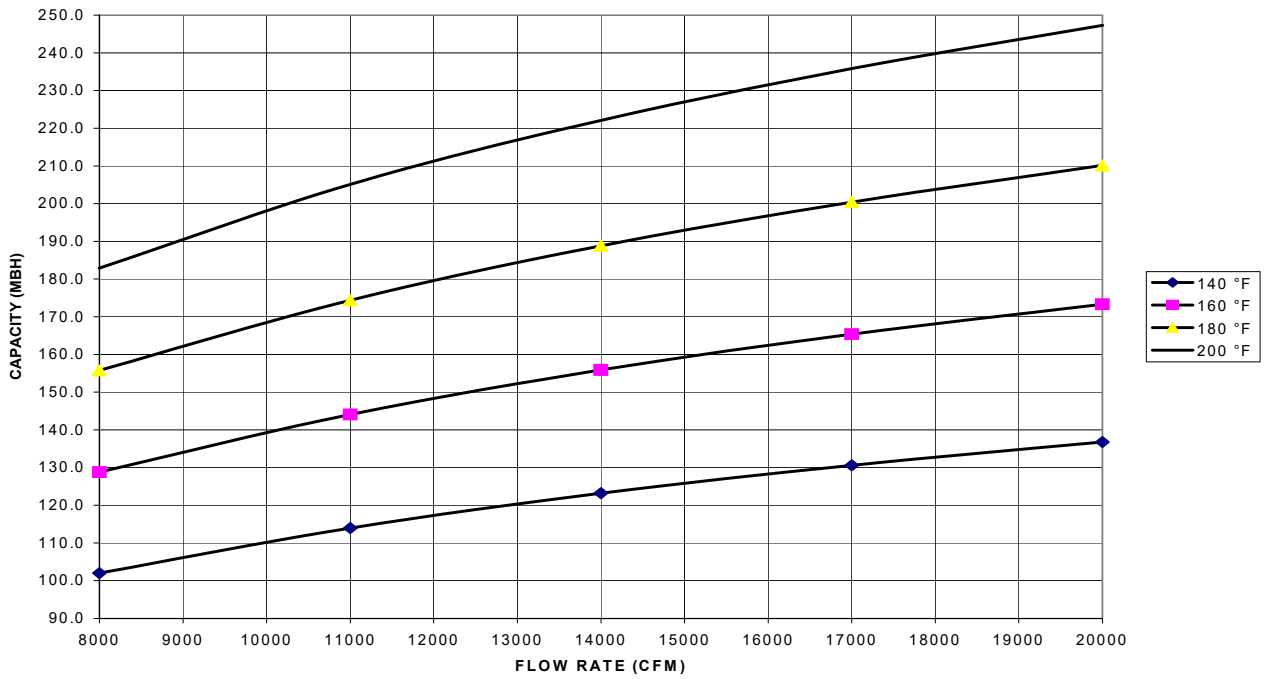

FIGURE 40 - HOT WATER COIL - 40 TON, 1 ROW, AT 10 GPM

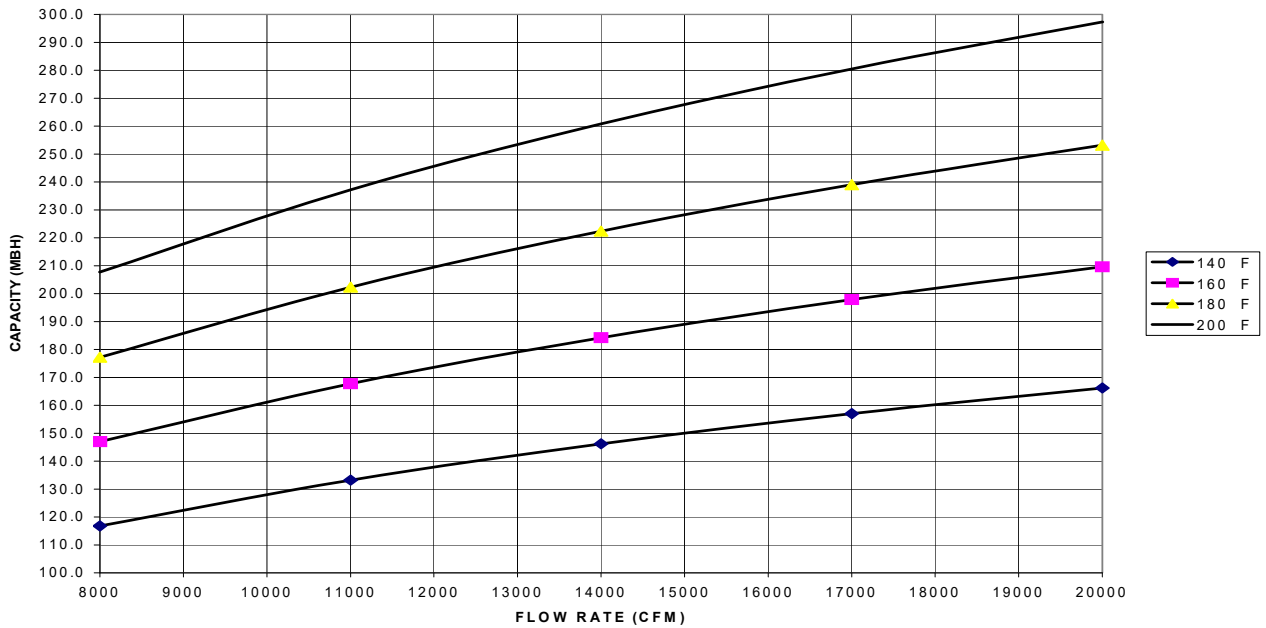

FIGURE 41 - HOT WATER COIL - 40 TON, 1 ROW, AT 20 GPM

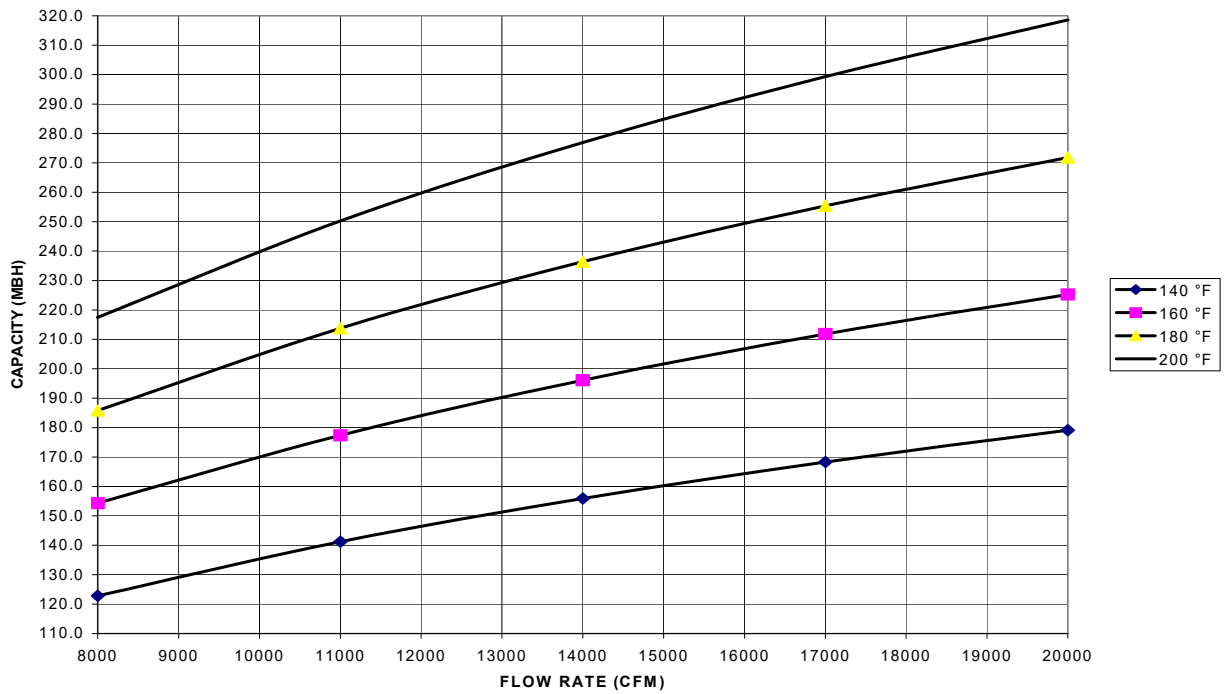

FIGURE 42 - HOT WATER COIL - 40 TON, 1 ROW, AT 30 GPM

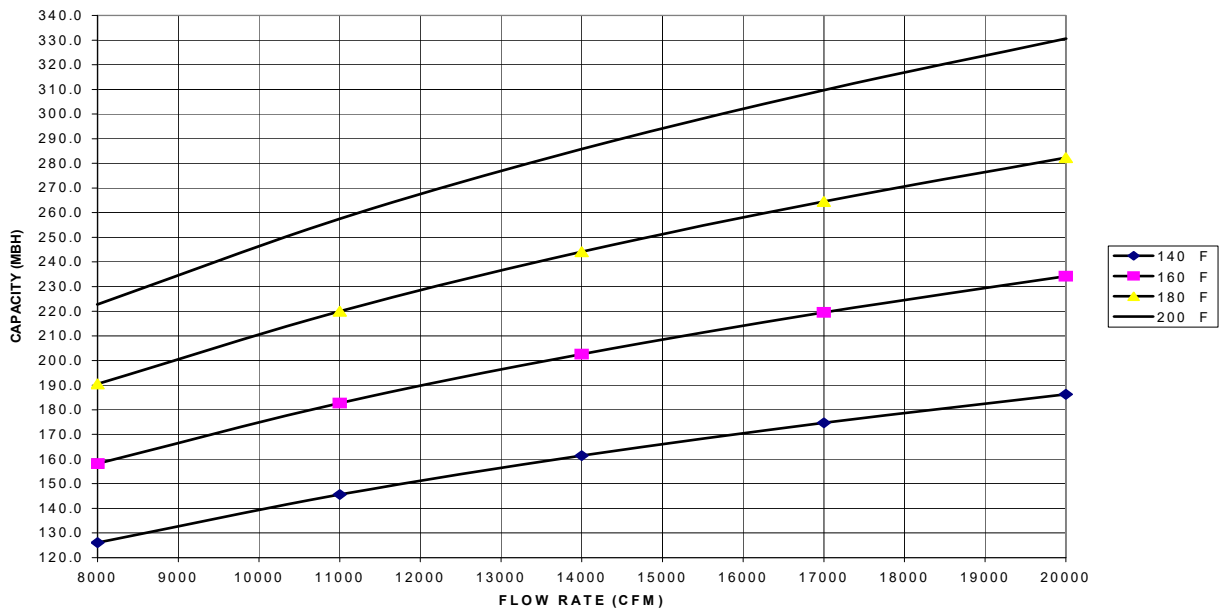

FIGURE 43 - HOT WATER COIL - 40 TON, 1 ROW, AT 40 GPM

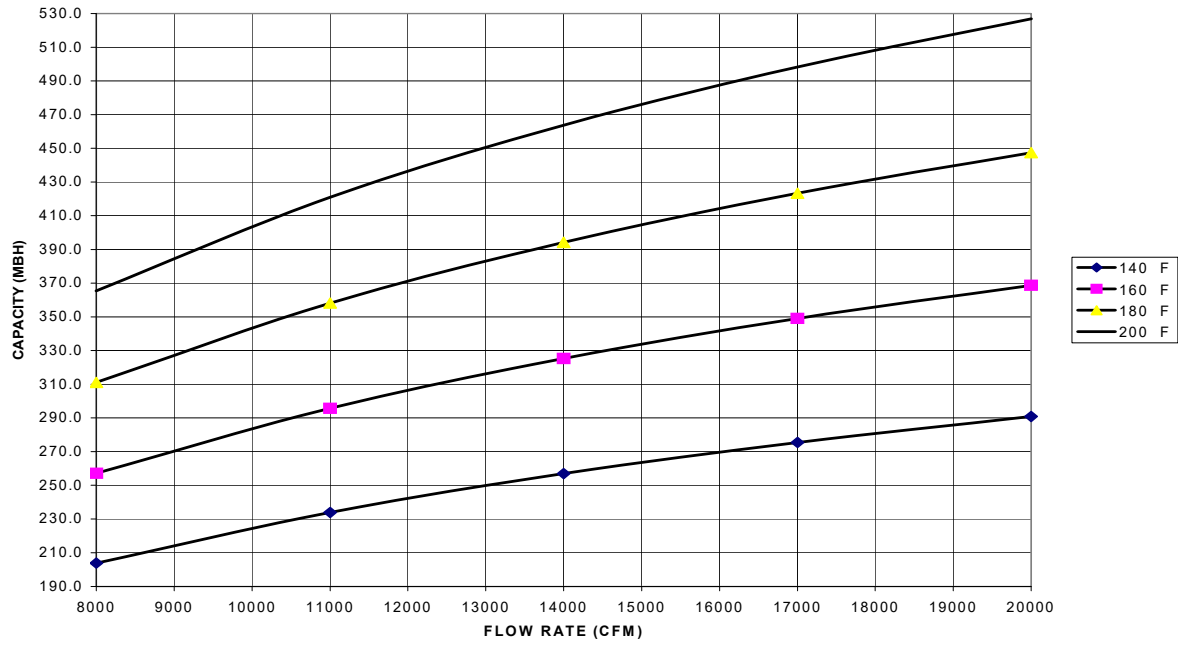

FIGURE 44 - HOT WATER COIL - 40 TON, 2 ROW, AT 20 GPM

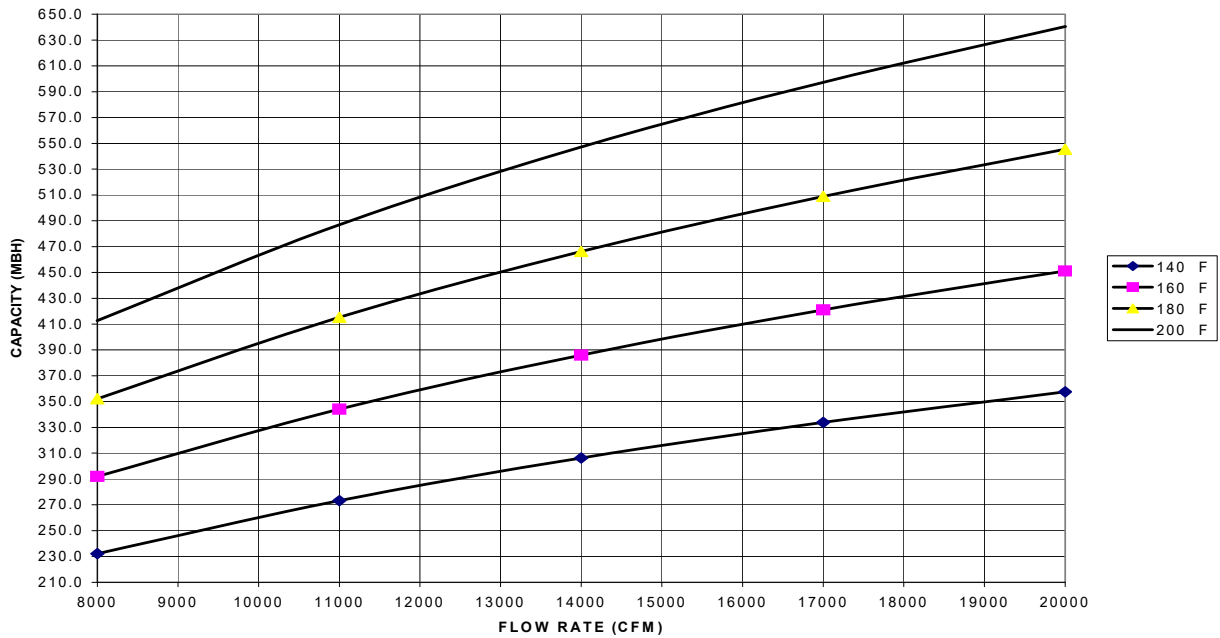

FIGURE 45 - HOT WATER COIL - 40 TON, 2 ROW, AT 40 GPM

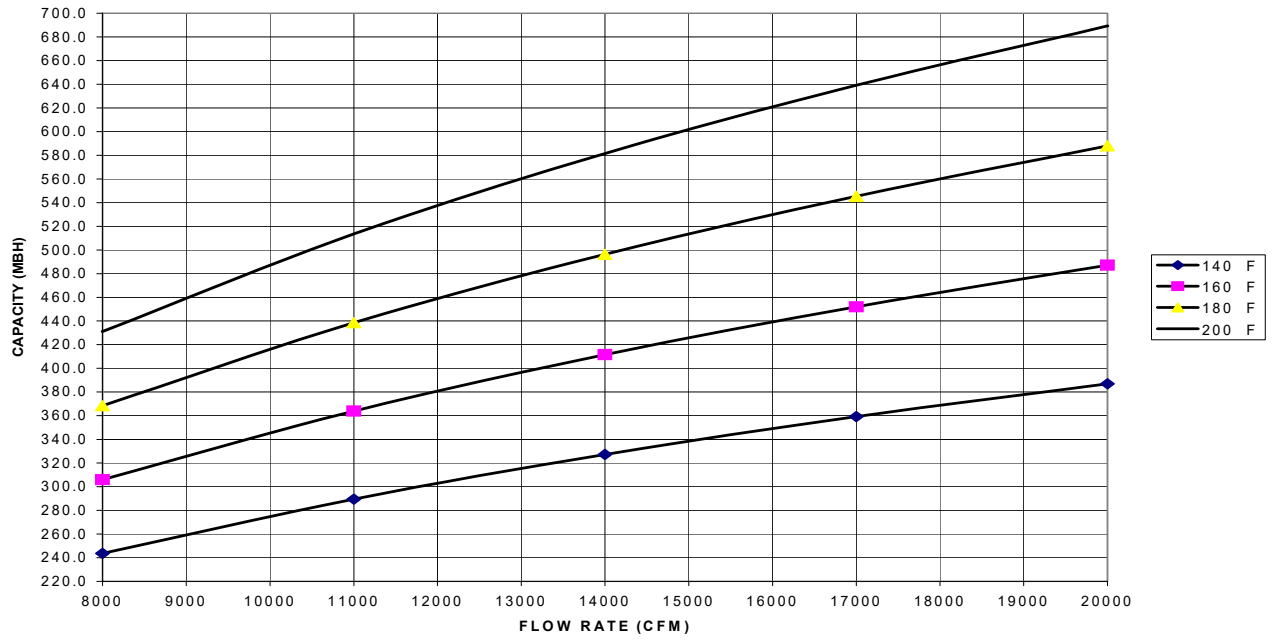

FIGURE 46 - HOT WATER COIL - 40 TON, 2 ROW, AT 60 GPM

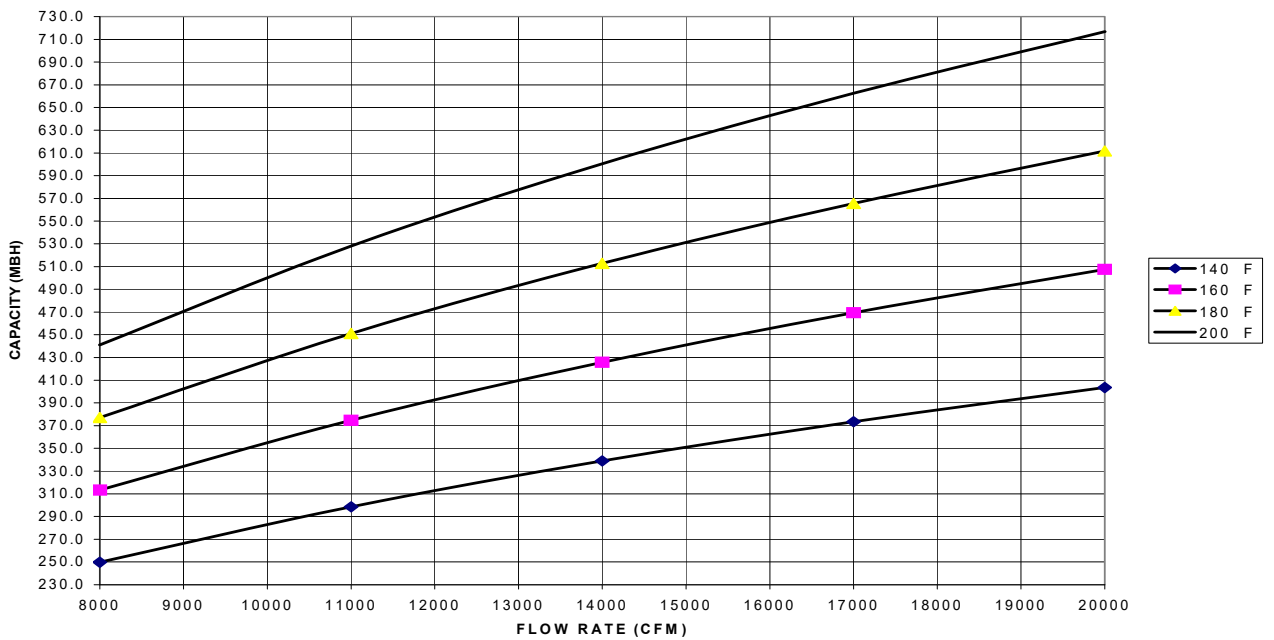

FIGURE 47 - HOT WATER COIL - 40 TON, 2 ROW, AT 80 GPM

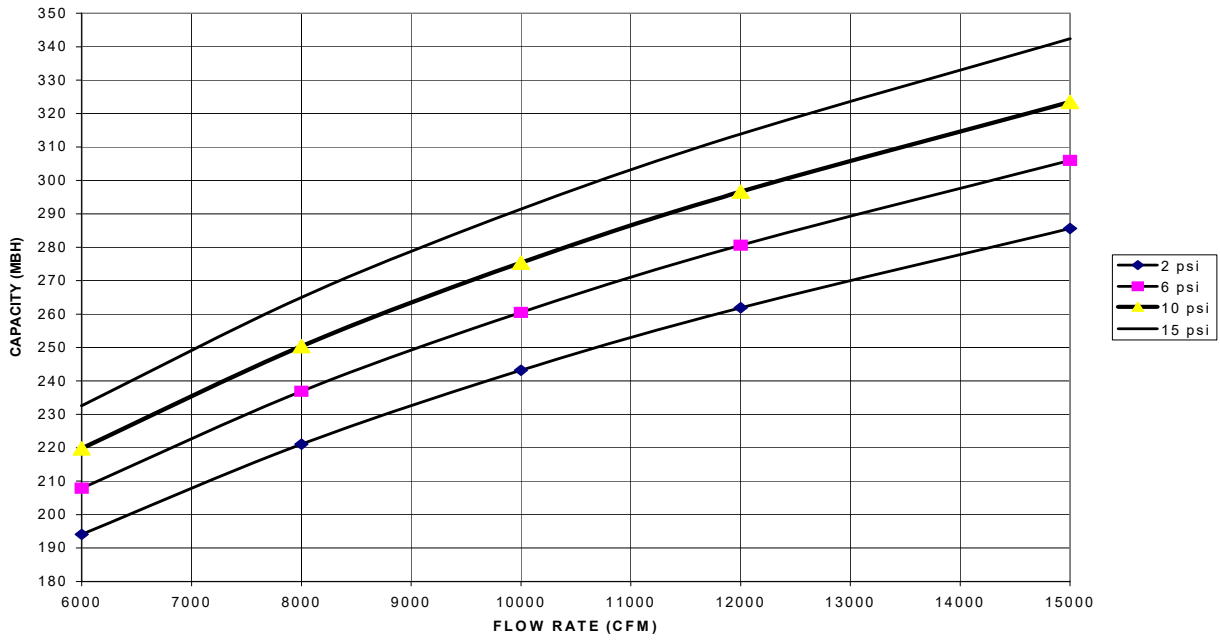

FIGURE 48 - STEAM COIL - 25 & 30 TON (1 ROW)

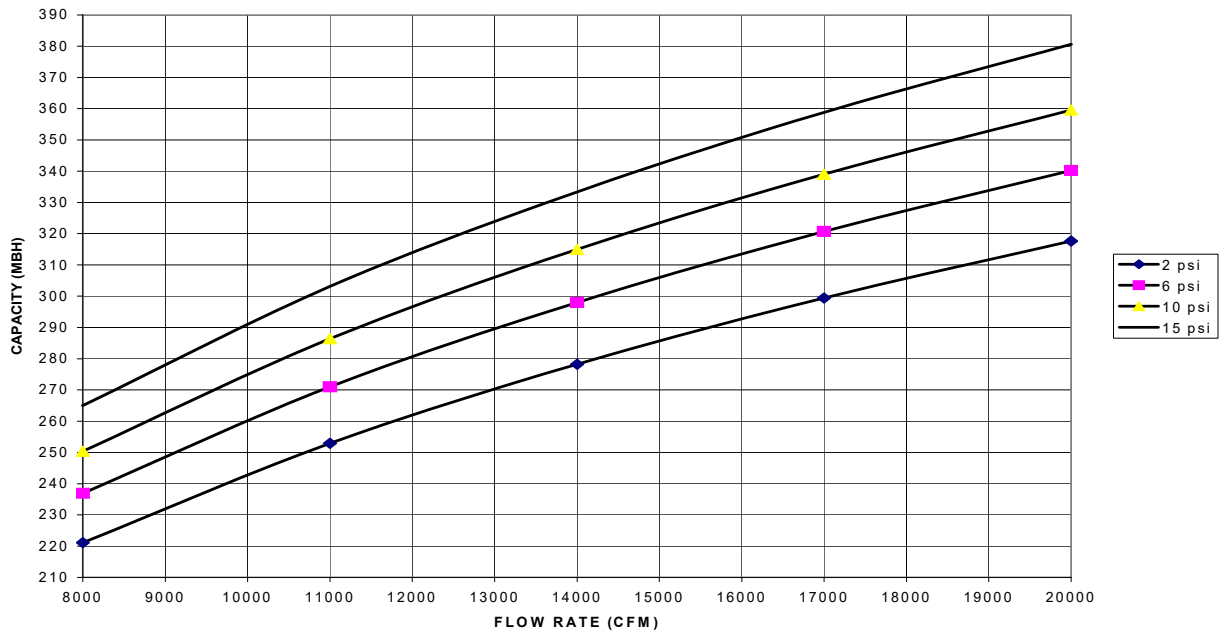

FIGURE 49 - STEAM COIL - 40 TON (1 ROW)

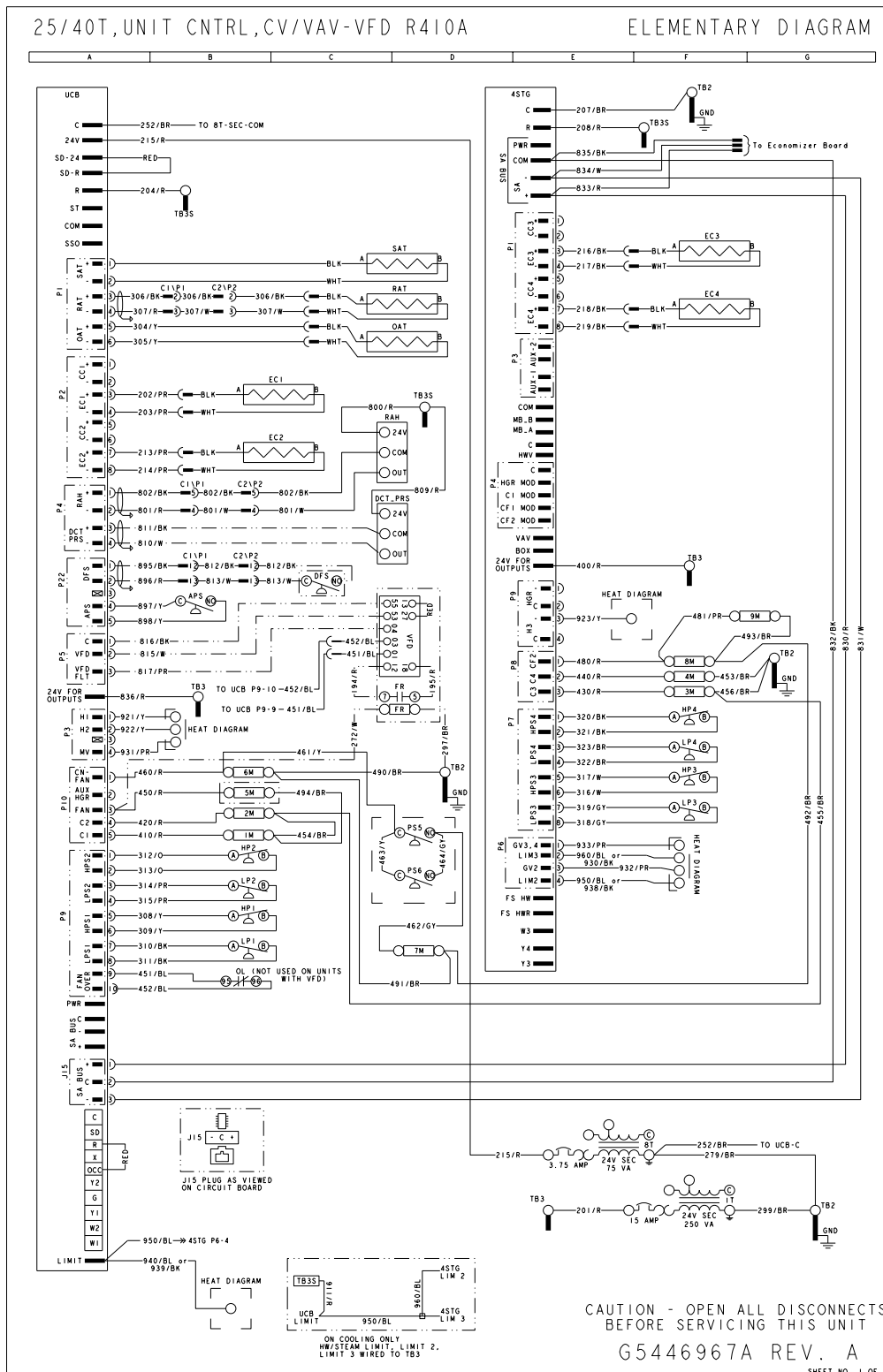

FIGURE 50 - TYPICAL CONTROL WIRING

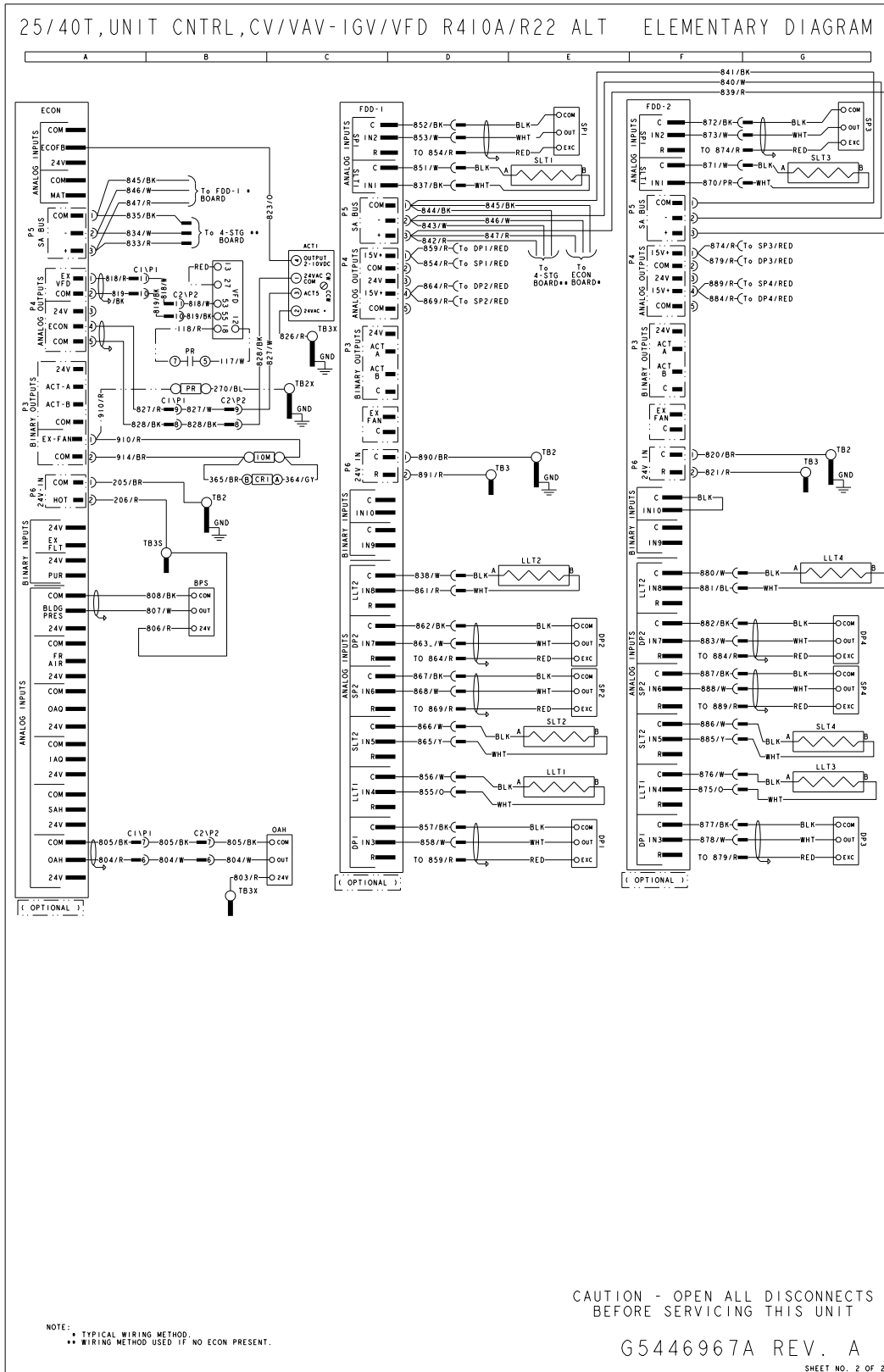

FIGURE 51 - TYPICAL CONTROL WIRING CONTINUED

LEGEND

UNIT CONTROLS, R410A

- I-33FU FUSES (SEE CHART FOR AMP.)
- IM CONTACTOR, COMPRESSOR No.1
- IM-AUX AUXILIARY SWITCH 1
- IT TRANSFORMER, 250 VA, 24V SEC.
- 2CB BREAKER, CIRCUIT 20.0 AMP
- 2M CONTACTOR, COMPRESSOR No.2
- 2M-AUX AUXILIARY SWITCH 2
- 3M CONTACTOR, COMPRESSOR No.3
- 3M-AUX AUXILIARY SWITCH 3
- 4M CONTACTOR, COMPRESSOR No.4
- 4M-AUX AUXILIARY SWITCH 4
- 45TG FOUR STAGE ADD ON BOARD
- 4T TRANSFORMER, 120V OUTLET
- 5M CONTACTOR, INDOOR BLOWER
- 6M CONTACTOR, CONDENSER FAN No.1
- 7M CONTACTOR, CONDENSER FAN No.2
- 8M CONTACTOR, CONDENSER FAN No.3
- 9M TRANSFORMER, 175VA, 24V SEC.
- 9M CONTACTOR, CONDENSER FAN No.4
- 9-12T TRANSFORMER, 175VA, (GAS HEAT, NOT USED ON 230V)
- 10M CONTACTOR, POWER EXHAUST FAN
- ACT1 ACTUATOR, ECONOMIZER
- ACT2 ACTUATOR, POWER EXHAUST DAMPERS / VFD
- APS SWITCH, AIR PROVING
- BPS BUILDING PRESSURE SENSOR
- CI-C10 CAP, MATE-N-LOCK FEMALE CONNECTOR
- CCH1-4 CRANKCASE HEATER
- DTS SWITCH, DIRTY FILTER
- DCT-PRS DUCT PRESSURE SENSOR
- DMI-4 MOTOR, DRAFT FAN (GAS HEAT)
- DPI-4 TRANSDUCER, DISCHARGE PRESSURE
- DS SWITCH, POWER DISCONNECT
- ECI-4 SENSOR, EVAPORATOR COIL
- ECON ECONOMIZER CONTROLLER
- FC MODULATING FURNACE CONTROL BOARD (GAS HEAT)
- FDD-1 FAULT DETECTION DIAGNOSTIC BOARD, SYSTEM 1&2
- FDD-2 FAULT DETECTION DIAGNOSTIC BOARD, SYSTEM 3&4
- FR RELAY, SUPPLY FAN RUN PERMIT RELAY (VFD ONLY)
- FS FLAME SENSOR (GAS HEAT)
- GVI-4 GAS VALVE (GAS HEAT)
- HPI-4 SWITCH, HIGH PRESSURE
- HPC CONTROL, HEAD PRESSURE, VARIABLE FREQUENCY DRIVE
- ICI-4 MODULE, IGNITION CONTROL (GAS HEAT)
- ID-FAN MOTOR, INDOOR BLOWER
- LLTI-4 SENSOR, LIQUID LINE TEMPERATURE
- LP1-4 SWITCH, LOW PRESSURE
- LS1-4 SWITCH, LIMIT (GAS HEAT)
- MAT MIXED AIR TEMPERATURE (GAS HEAT)
- OAH OUTSIDE AIR HUMIDITY
- OAT OUTDOOR AIR TEMPERATURE
- OD-FANI-4 MOTOR, OUTDOOR FAN
- OL OVERLOAD (SEE CHART FOR SETTINGS)
- P1-P10 PLUG, MATE-N-LOCK, MALE CONNECTOR
- PEVFD VARIABLE FREQUENCY DRIVE, POWER EXHAUST
- PR RELAY, POWER EXHAUST RUN PERMIT (VFD ONLY)
- PS1-4 SWITCH, PRESSURE - MAKES Ø 0.33 IWC (GH)
- PS5 SWITCH, HEAD PRESSURE (FAN CYCLING/SYS.1)
- PS6 SWITCH, HEAD PRESSURE (FAN CYCLING/SYS.2)
- RAH RETURN AIR HUMIDITY
- RAT RETURN AIR TEMPERATURE
- RS1-4 SWITCH, ROLLOUT (GAS HEAT)
- SAT SUPPLY AIR TEMPERATURE
- SAT-2 SUPPLY AIR TEMPERATURE (GAS HEAT)
- SLTI-4 SENSOR, SUCTION LINE TEMPERATURE
- SP1-4 TRANSDUCER, SUCTION PRESSURE
- TB1 TERMINAL BLOCK, MAIN POWER
- TB2 TERMINAL BLOCK, 24V COMMON
- TB2H TERMINAL BLOCK, HEAT OPTION
- TB3 TERMINAL BLOCK, 24V
- TB3-6 TERMINAL BLOCK
- TB3B TERMINAL BLOCK
- TB3H TERMINAL BLOCK, HEAT OPTION
- TB3L TERMINAL BLOCK
- TB3S TERMINAL BLOCK, 24V
- TB7 TERMINAL GROUNDING
- TB9 TERMINAL GROUNDING
- UCB UNIT CONTROL BOARD
- VFD VARIABLE FREQUENCY DRIVE

_____ FACTORY WIRING AND DEVICES
 - - - - - OPTIONAL WIRING AND DEVICES
 _____ FIELD WIRING AND DEVICES

NOTES:

1. ALL FIELD WIRING TO BE ACCOMPLISHED FOLLOWING CITY, LOCAL AND/OR NATIONAL CODES IN EFFECT AT TIME OF INSTALLATION OF THIS UNIT.
2. CAUTION: LABEL ALL WIRES PRIOR TO DISCONNECTION WHEN SERVICING CONTROLS. WIRING ERRORS CAN CAUSE IMPROPER AND DANGEROUS OPERATION. IF ANY OF THE WIRE AS SUPPLIED WITH THIS UNIT MUST BE REMOVED, IT MUST BE REPLACED WITH THE 16S DESIGN. 16S WIRE OR EQUIVALENT CLEARLY RENUMBERED FOR IDENTIFICATION. VERIFY PROPER OPERATION AFTER SERVICING.
3. ALL MOTORS ARE PROTECTED UNDER PRIMARY, SINGLE PHASE CONDITION. ALL CONDENSER FAN MOTORS ARE INTERNALLY PROTECTED. COMPRESSORS ARE PROTECTED BY A SOLID STATE DEVICE MOUNTED IN THE COMPRESSOR TERMINAL BOX. THE POWER EXHAUST AND SUPPLY FAN MOTORS ARE PROTECTED THROUGH THE 3M 10M STARTERS. SEE THE CHART BELOW FOR THE MANUFACTURER AND PART NUMBER OF THE OVERLOAD HEATERS.
4. SEE UNIT NAMEPLATE FOR MAXIMUM OVERCURRENT PROTECTIVE DEVICE SIZE AND MINIMUM CIRCUIT AMPACITY.
5. 208/230V UNIT TRANSFORMERS ARE FACTORY WIRED FOR 230V. SEE BELOW FOR 208V 380V/415-50HZ UNIT TRANSFORMERS ARE FACTORY WIRED FOR 380V FOR A 208V SUPPLY, MOVE WIRE 132/R TO TERMINAL H2 ON T1. FOR A 208V SUPPLY, MOVE WIRE 710/R TO TERMINAL H2 ON AT. FOR A 380V SUPPLY, MOVE WIRE 132/R TO TERMINAL H2 ON T1. FOR A 380V SUPPLY, MOVE WIRE 710/R TO TERMINAL H2 ON AT.
6. SET THE A/B SWITCH ON ACT3 TO THE "B" POSITION. WHEN ECONOMIZER IS INSTALLED, SET THE L/R SWITCH ON ACT1 TO THE "R" POSITION.
7. WHEN USING THE DEMAND VENTILATION CO2 OVERRIDE, THE CO2 SENSOR MUST BE POWERED BY AN ISOLATED TRANSFORMER.

PRESSURE CONTROLS			
DEVICE	OPERATING	PRESSURE (PSIG)	
HP	4	825	5 500 25
LP1	4	50	5 71 5
PS5	6	300	5 360 10

TEMPERATURE CONTROLS			
DEVICE	CONTROL	SETPOINT (DEG F)	
RS1	4	180	12 --- --
CLO1	40	5	50 6
CLO2	0	5	10 6

OVERLOAD RELAY SETTINGS/NO HEATER REQ'D					
MOTOR H.P.	208/230V	460V	575V	380/415 50HZ	380/415 60HZ
5 HP	14/14	7	5	8	12
7.5 HP	21/20	10	8	10	12
10 HP	29/27	13	10	10	16
15 HP	41/38	21	16	16	20
20 HP	50/47	24	19	19	25
25 HP	63/60	30	25	25	30

FURNAS - OVERLOAD HEATER ELEMENT PART No. 3					
MOTOR H.P.	208/230V	460V	575V	380/415 50HZ	380/415 60HZ
5 HP	K57	K43	K39	K50	K50
7.5 HP	K67	K53	K50	K56	K54
10 HP	K70	K57	K54	K60	K58
15 HP	K74	K63	K61	K67	K64
20 HP	K77	K69	K63	K70	K70
25 HP	K83	K72	K69	K73	K73

(3 REQUIRED PER 5M OR 10M STARTER)

FUSE SIZE (AMPS)•SEE NOTE 4**							
FUSE	HP	208/230V	460V	575V	380V	380/415 50HZ	CLASS
1-12FU (25T)	--	35	20	20	25	20	RR-5
1-12FU (30T)	--	50	25	20	30	25	RR-5
1-12FU (40T)	--	60	30	25	40	30	RR-5
13-15FU	7.5	35	15	12	20	20	RR-5
"	"	10	50	25	20	25	RR-5
"	"	15	70	35	25	40	RR-5
"	"	20	100	40	35	50	RR-5
"	"	25	110	50	40	60	RR-5
16-18FU (25T)	--	30	15	12	20	15	RR-5
16-18FU (30-40T)	--	40	20	15	25	20	RR-5
16-18FU (40-50T)	--	8	4	---	---	---	RR-5
16-18FU (4 units 30-40T)	--	10	5	---	---	---	CC
19-21FU	5	25	12	10	12	12	RR-5
"	"	7.5	35	15	12	20	RR-5
"	"	10	50	25	20	25	RR-5
"	"	15	70	35	25	40	RR-5
22-23FU	--	3	1.5	1.5	1.5	1.5	CC-600V
24-25FU	--	4	3	2.5	3	3	CC-600V
26-29FU	--	30	15	15	15	15	CC-600V
26-27FU	--	3	(250V)	---	---	---	*SPL1
30FU	--	10	(250V)	---	---	---	*SPL2
31-33FU	--	3	1.5	1.5	---	---	CC-600V
50FU (25T HPC)	--	35	15	20	25	25	RR-5

ALL CLASS RR-5 FUSES ARE RATED AT 250V FOR 208/230V UNITS AND AT 600VAC FOR ALL OTHER VOLTAGES.
 ALL CLASS CC FUSES ARE RATED AT 600VAC.
 *SPL1- REPLACE 30FU (10A, 250V) WITH BUSSMAN MDL10, GOULD SHANNUT 6DL10
 *SPL2- REPLACE 26-27FU (3A, 250V) WITH BUSSMAN MDL3, GOULD SHANNUT 6DL3, LITTLEFUSE 313003
 ** - VALUES REFLECT FUSE SIZES FOR UNITS WITH (16V/VFD)

CAUTION: OPEN ALL DISCONNECTS BEFORE SERVICING THIS UNIT

G5446964A REV. A

FIGURE 52 - LEGEND

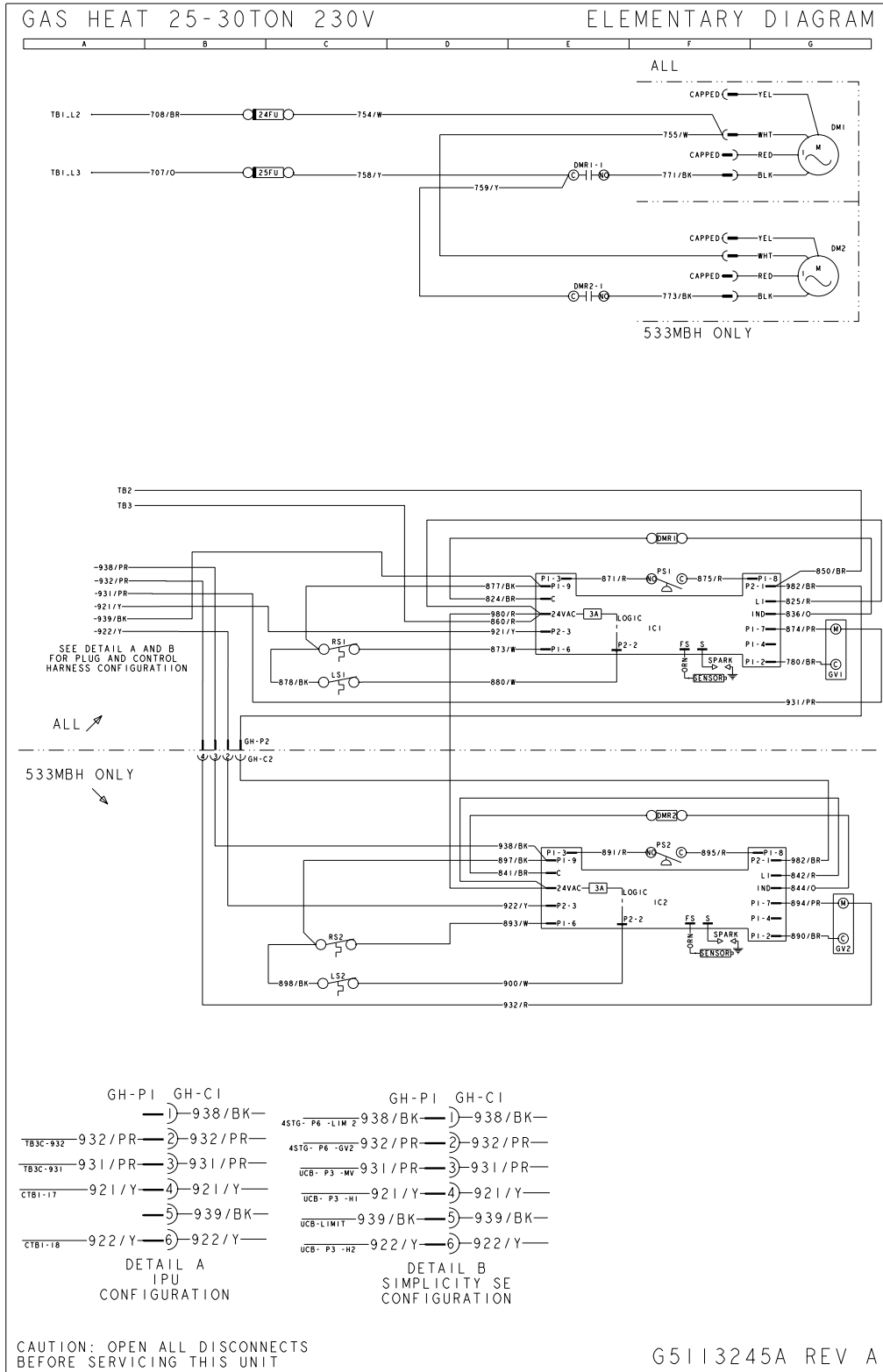

FIGURE 53 - TYPICAL 25 TON POWER WIRING

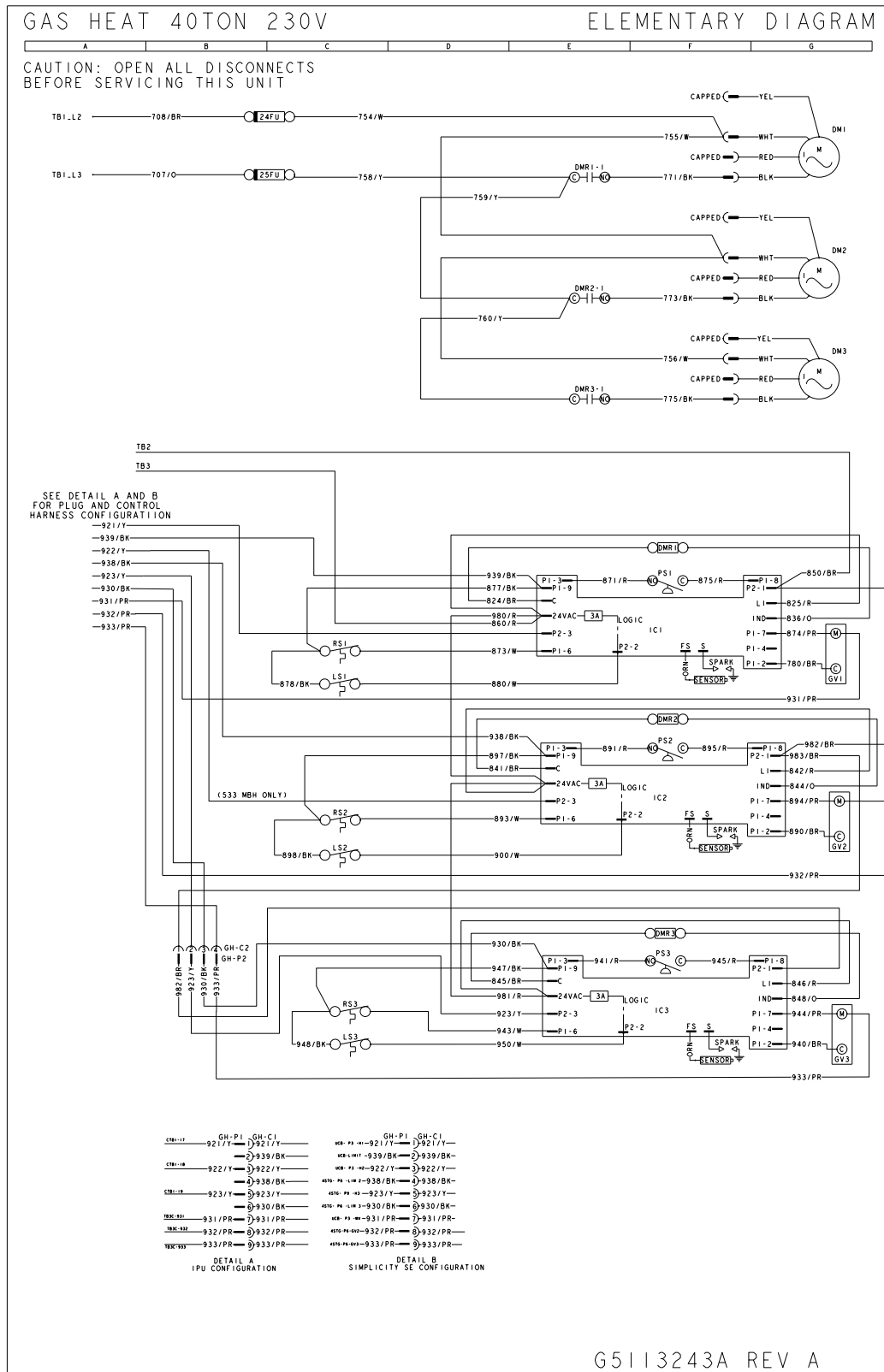

FIGURE 54 - TYPICAL STANDARD GAS HEAT WIRING

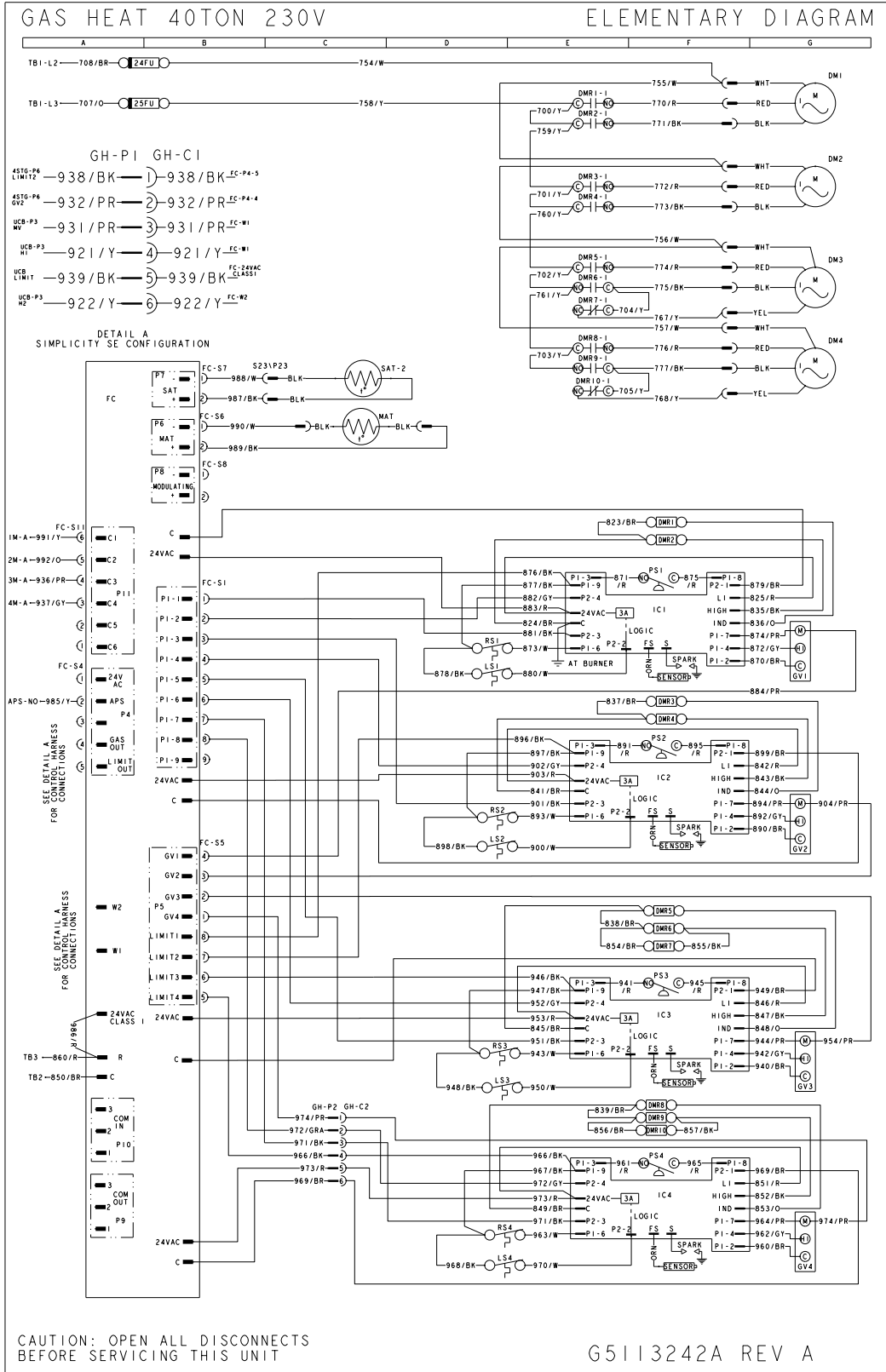

FIGURE 55 - TYPICAL MODULATING GAS HEAT WIRING

GAS FURNACE SAFETY FEATURES

COMBUSTION AIR PROVING

Combustion air proving is provided by a pressure switch. As the motor approaches full speed, this switch closes before any other circuit or gas component can be energized.

ROLLOUT

Rollout protection is provided by a switch mounted on the heat shield of each furnace module. The switch senses any flame or excessive heat in the burner compartment. When the switch opens, the furnace module is immediately locked out until there is a break in power to the specific furnace module and the manual reset is reset. Note that only the module with the open rollout switch will be locked out, the remaining modules will continue to operate although all should be inspected.

A trip of the rollout switch likely indicates a flue restriction, an opening in the flue passageway, defective pressure switch or a loose combustion blower wheel. Corrective action should be taken accordingly.

MAINTENANCE

NORMAL MAINTENANCE

CAUTION

Prior to any of the following maintenance procedures, shut off all power to the unit. Failure to do so could cause personal injury.

Label all wires prior to disconnection when servicing controls. Wiring errors can cause improper and dangerous operation. Verify proper operation after servicing.

Periodic maintenance normally consists of changing or cleaning filters and (under some conditions) cleaning the main burners.

FILTERS

Inspect once a month. Replace disposable or clean permanent type as necessary. The dimensional size of the replacement filter must be the same as the replaced filter (Refer to Table 15).

MOTORS

Outdoor fan motors are permanently lubricated and require no maintenance. Lubrication, if desired, is to be performed by a qualified service agency.

Ventor motors are factory lubricated for an estimated 10-year life.

Indoor Fan Motors - The indoor blower motor features ball-bearings that do not require periodic lubrication. Periodic lubrication of the motor bearings can extend the life but is optional.

CAUTION

Damage can occur if the bearings are over lubricated. Use grease sparingly.

To go to bypass mode, the bypass VFD as installed in this unit must be switched by hand on the front of the bypass enclosure in the fan cabinet of the rooftop unit. It does not automatically go to bypass mode if the drive fails.

The switches on the front of the bypass box control its run mode. For normal running:

- The ON/OFF rotary power switch must be in the ON position.
- The BYPASS/OFF/DRIVE switch S1 should be in the DRIVE position.
- The HAND/STOP/AUTO switch S2 should be in the AUTO position, so that the unit control will properly run the fan and control the speed.
- The TEST/NORMAL switch S3 should be in the NORMAL position.

CAUTION

If the unit is operated with the manual bypass switch in the LINE (BYPASS) position and there are VAV boxes present, the boxes must be driven to the full-open position using a customer-supplied power source to prevent over-pressuring the ductwork.

WARNING

Perform all maintenance operations on the blower motor with power disconnected from the unit. Do not attempt to lubricate bearings with the unit in operation.

TABLE 68: INDOOR BLOWER BEARING LUBRICATION SCHEDULE

Shaft Size (Inches)	Operating Speed (RPM)			
	500	1000	1500	2000
	Relubrication Cycle (Months)			
1-1/16 - 1-7/16	6	6	6	6
1-1/2 - 1-3/4	6	6	6	4
1-7/8 - 2-3/16	6	6	4	4
2 -1/4 - 3	6	4	4	2

On an annual basis, check the motor for accumulations of dust, etc. That may block the cooling slots in the motor shell. Check for loose, damaged or misaligned drive components. Check that all mounting bolts are tight. Replace defective parts as required.

If desired, every three years remove both pipe plugs at each end shell and clean out any hardened grease or foreign matter. Replace one plug on each end with a clean grease fitting. Using a low pressure grease gun, pump grease (Chevron SRI-2 or equivalent) into the bearing cavity until new grease shows at the open port. Do not over-lubricate. Run the motor for ten minutes until excess grease is purged from the cavity. Replace the plugs.

FAN DRIVES

Units are supplied with fan shaft bearings that do not require maintenance but may be relubricated per Table 68.

Lubricate with a premium quality NLGI 2 grade multi-purpose roller bearing grease having corrosion inhibitors, anti-oxidant additives and mechanical stability for high speed operation. The grease should also have a minimum base oil viscosity of 500 SUS at 100°F. Do not use a heavy, long fibered grease.

The presents of dirt, moisture or chemical fumes around the bearings requires more frequent lubrication.

Fill bearings with lubricant prior to extended shutdown or storage. Rotate the shaft monthly during idle periods.

Avoid excessive grease purging from seals during lubrication, this reduces the life of the bearing.

OUTDOOR COIL

Dirt should not be allowed to accumulate on the outdoor coil surface or other parts in the air circuit. Cleaning should be as often as necessary to keep coil clean. Use a brush, vacuum cleaner attachment, or other suitable means. If water is used to clean coil, be sure power to the unit is shut off prior to cleaning.

NOTE: Exercise care when cleaning the coil so that the coil fins are not damaged.

Do not permit the hot condenser air discharge to be obstructed by overhanging structures or shrubs.

GAS BURNER

Periodically (at least annually at the beginning of each heating season) make a visual check of the main burner flame.

TO CLEAN BURNERS

Remove them from the furnace as explained in BURNER INSTRUCTIONS. Clean burners with hot water applied along top of the burner.

COMBUSTION AIR DISCHARGE

Visually inspect discharge outlet periodically to make sure that the buildup of soot and dirt is not excessive. If necessary, clean to maintain adequate combustion air discharge.

CLEANING FLUE PASSAGES AND HEATING ELEMENTS

With proper combustion adjustment, the heating element of a gas fired furnace will seldom need cleaning. If the element should become sooted, it can be cleaned as follows:

1. Remove the burner assembly as outlined in BURNER INSTRUCTIONS.
2. Remove the screws holding the top of the flue collector box. Carefully remove the top of the flue collector box. The draft wheel, housing, and draft motor can remain assembled to the flue box top, if cleaning of these components is not required.
3. This will provide access to flue baffles, then remove the flue baffles from the tube interiors. To remove, the flue baffles, remove the stainless steel screws from the vest panel. Refer to Figure 56.
4. Using a wire brush on a flexible wand, brush out the inside of each heat exchanger from the burner inlet and flue outlet ends.
5. Brush out the inside of the flue collector box, and the flue baffles.
6. Run the wire brush down the vent hoods from the flue collector end.
7. If soot build-up is particularly bad, remove the vent motor and clean the wheels and housings. Run the wire brush down the flue extension at the outlet of the vent housings.
8. After brushing is complete, blow all brushed areas with air or nitrogen. Vacuum as needed.
9. Replace parts in the order they were moved in steps 1 to 4.
10. Assure that all seams on the vent side of the combustion systems are air tight. Apply a high temperature (+500°F) sealing compound where needed (Dow Corning, Silastic 736, Loctite Superflex 596 or equivalent).

NOTE: One end of each flue baffle is provided with a sharper bend than the other end - this sharper bend must be positioned at the tube and attached with a stainless steel screw.

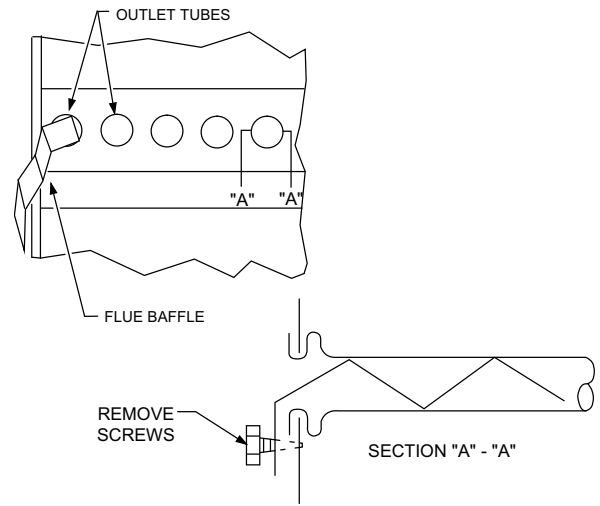

FIGURE 56 - TYPICAL FLUE BAFFLE

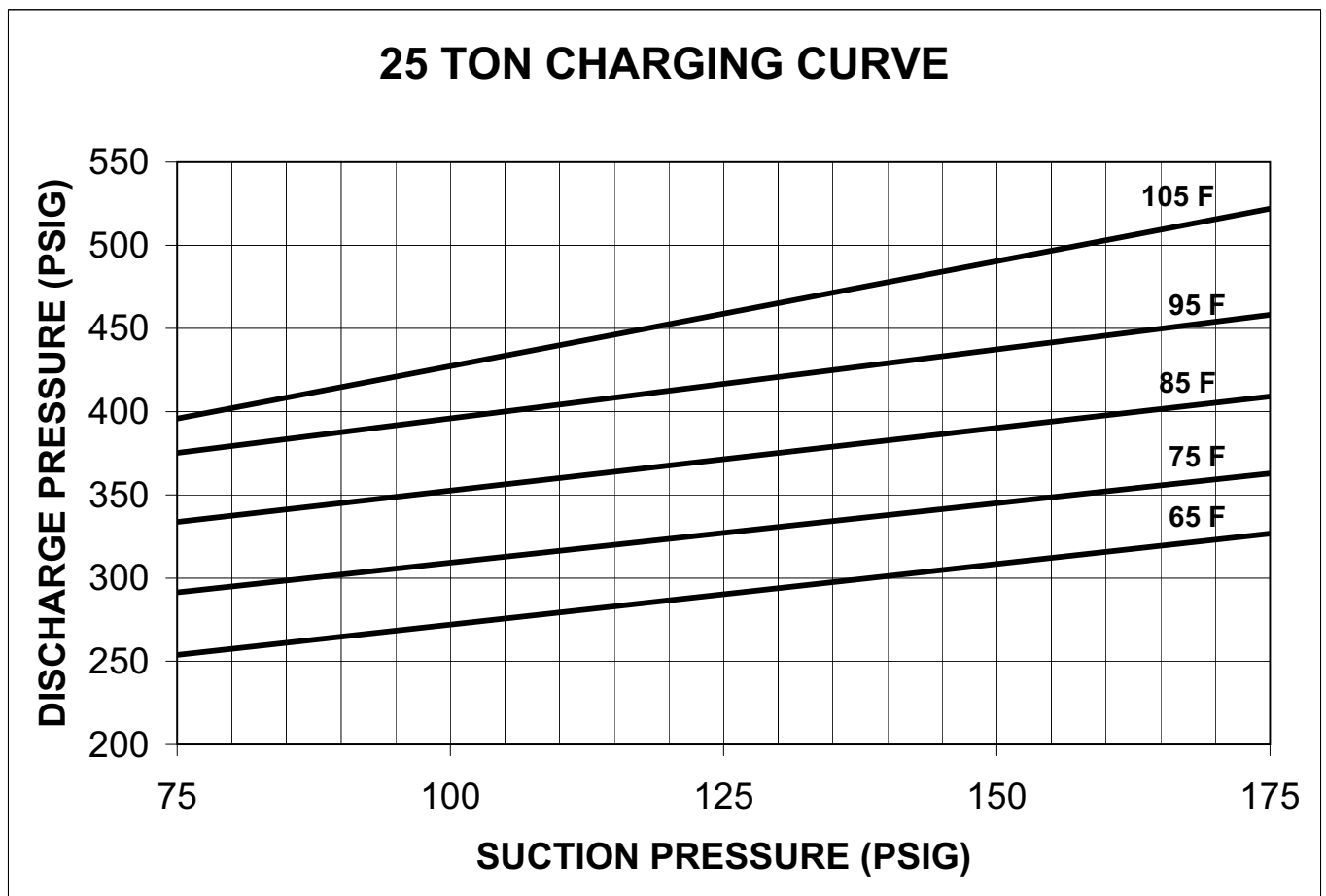

FIGURE 57 - 25 TON CHARGING CURVE

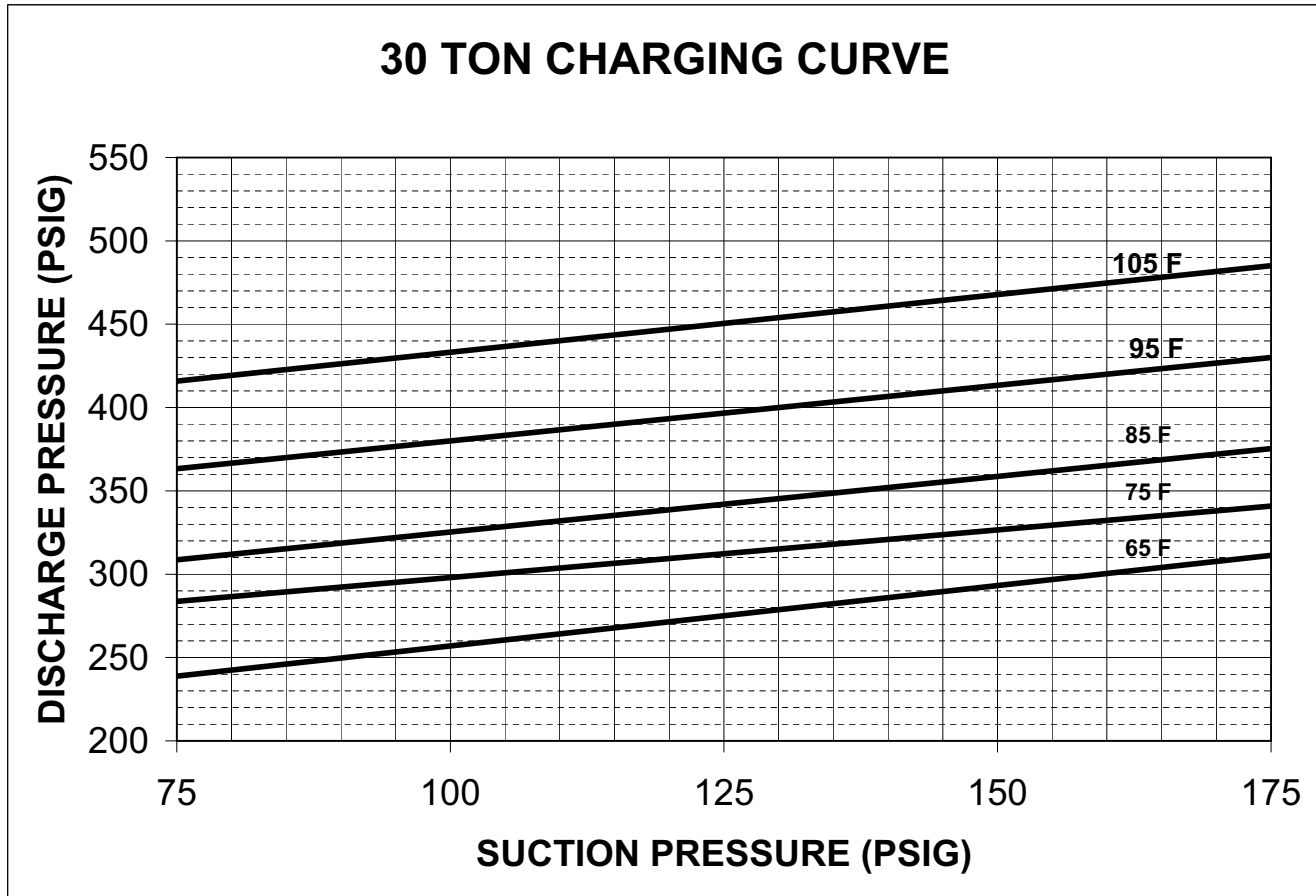

FIGURE 58 - 30 TON CHARGING CURVE

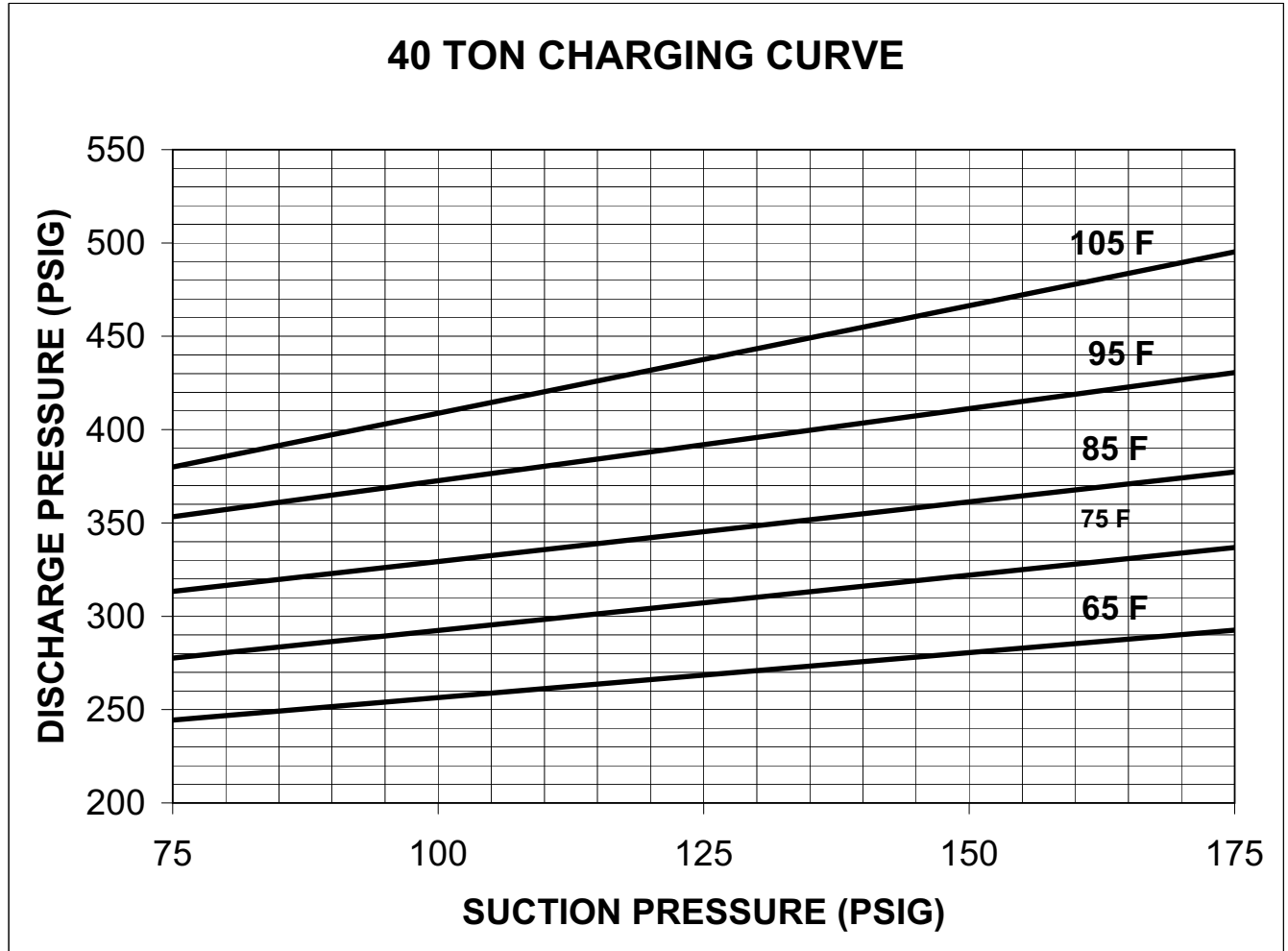

FIGURE 59 - 40 TON CHARGING CURVE

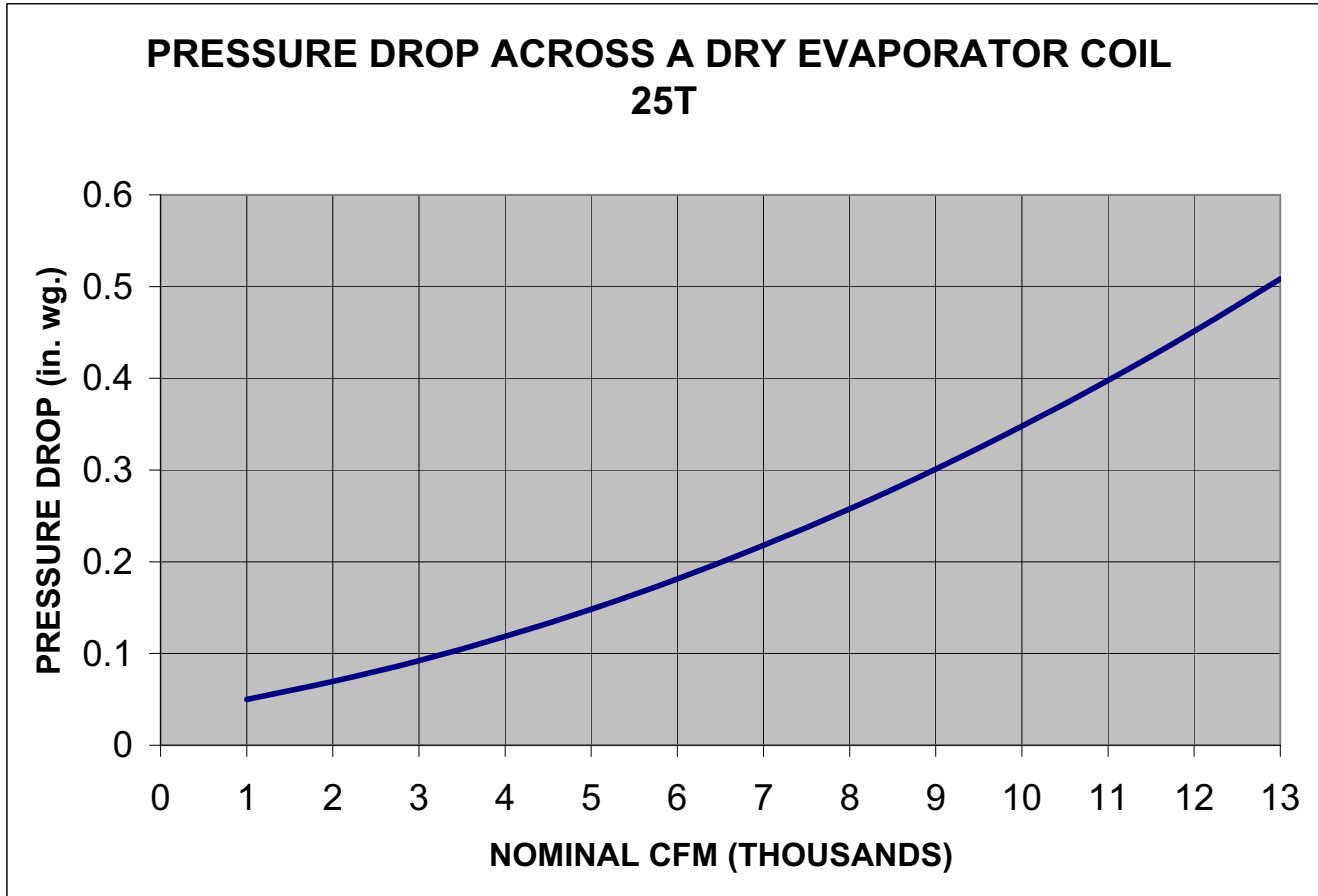

FIGURE 60 - PRESSURE DROP DRY EVAPORATOR COIL VS SUPPLY AIR CFM - 25 TON

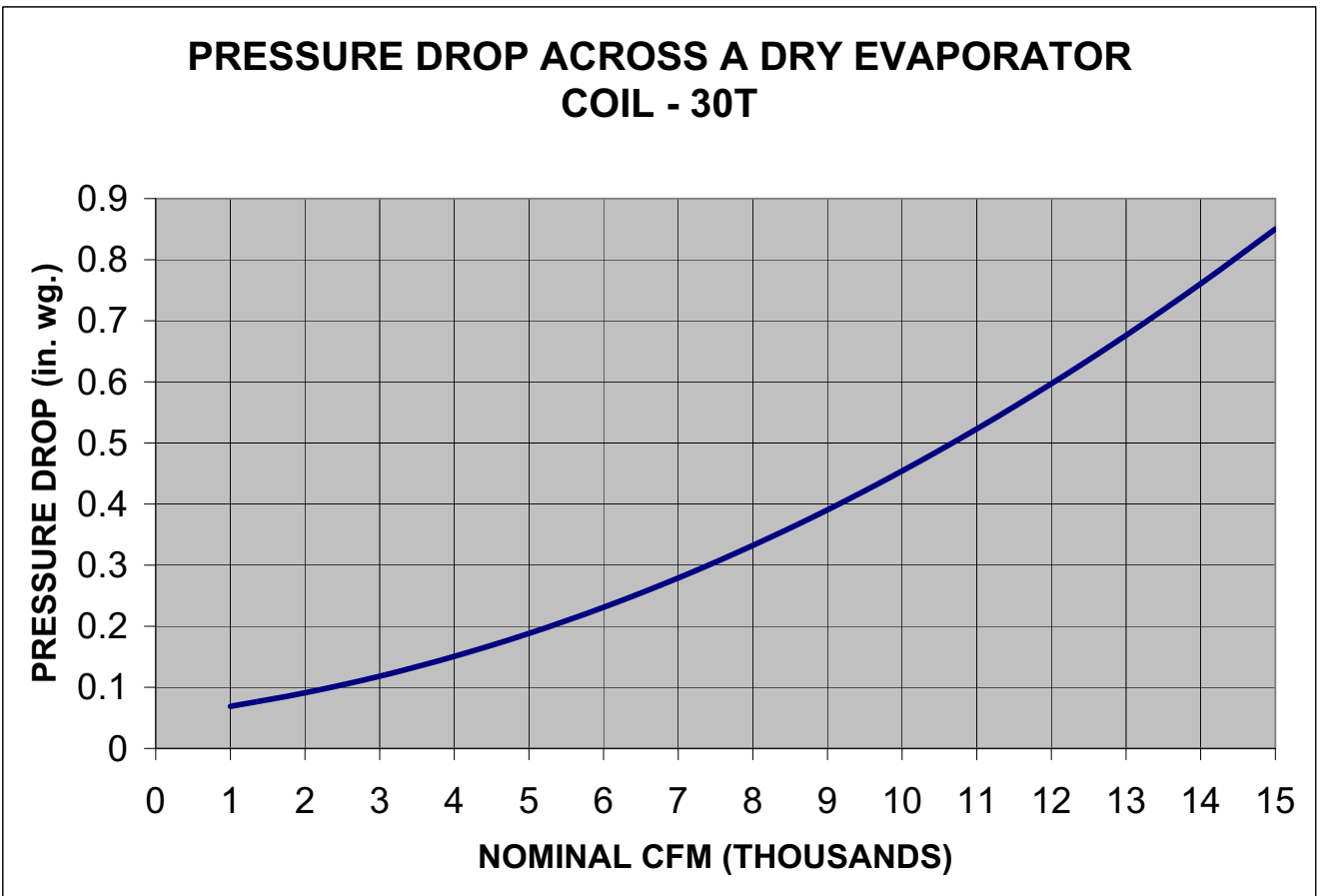

FIGURE 61 - PRESSURE DROP DRY EVAPORATOR COIL VS SUPPLY AIR CFM - 30 TON

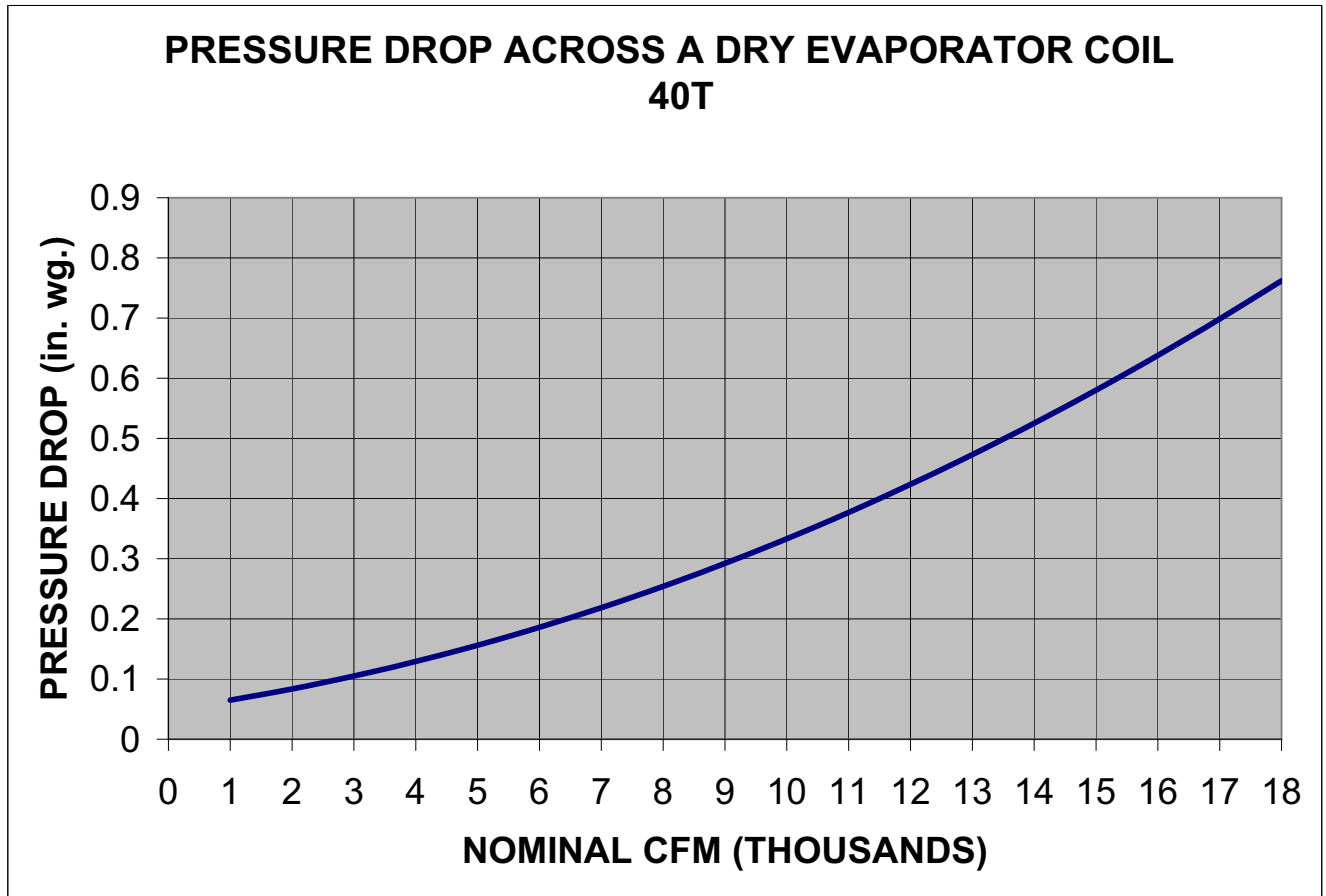

FIGURE 62 - PRESSURE DROP DRY EVAPORATOR COIL VS SUPPLY AIR CFM - 40 TON

START-UP SHEET**START-UP & SERVICE DATA INSTRUCTION****COMMERCIAL PACKAGE UNITS****3.0 To 40.0 TONS****START-UP CHECKLIST**

Date: _____

Job Name: _____

Customer Name: _____

Address: _____

City: _____ State: _____ Zip: _____

Model Number: _____ Serial Number: _____

Qualified Start up Technician: _____ Signature: _____

HVAC Contractor: _____ Phone: _____

Address: _____

Contractor's E mail Address: _____

Electrical Contractor: _____ Phone: _____

Distributor Name: _____ Phone: _____

WARRANTY STATEMENT

Johnson Controls/UPG is confident that this equipment will operate to the owner's satisfaction if the proper procedures are followed and checks are made at initial start up. This confidence is supported by the 30 day dealer protection coverage portion of our standard warranty policy which states that Johnson Controls/UPG will cover parts and labor on new equipment start up failures that are caused by a defect in factory workmanship or material, for a period of 30 days from installation. Refer to current standard warranty policy and warranty manual found on UPGnet for details.

In the event that communication with Johnson Controls/UPG is required regarding technical and/or warranty concerns, all parties to the discussion should have a copy of the equipment start up sheet for reference. A copy of the original start up sheet should be filed with the Technical Services Department.

The packaged unit is available in constant or variable air volume versions with a large variety of custom options and accessories available. Therefore, some variation in the startup procedure will exist depending upon the products capacity, control system, options and accessories installed.

This start up sheet covers all startup check points common to all package equipment. In addition it covers essential startup check points for a number of common installation options. Depending upon the particular unit being started not all sections of this startup sheet will apply. Complete those sections applicable and use the notes section to record any additional information pertinent to your particular installation.

Warranty claims are to be made through the distributor from whom the equipment was purchased.

EQUIPMENT STARTUP

Use the local LCD or Mobile Access Portal (MAP) Gateway to complete the start-up.

A copy of the completed start-up sheet should be kept on file by the distributor providing the equipment and a copy sent to:

Johnson Controls/UPG
 Technical Services Department
 5005 York Drive
 Norman, OK 73069

1034349-UCL-E-0817

SAFETY WARNINGS

The inspections and recording of data outlined in this procedure are required for start up of Johnson Controls/UPG's packaged products. Industry recognized safety standards and practices must be observed at all times. General industry knowledge and experience are required to assure technician safety. It is the responsibility of the technician to assess all potential dangers and take all steps warranted to perform the work in a safe manner. By addressing those potential dangers, prior to beginning any work, the technician can perform the work in a safe manner with minimal risk of injury.

 WARNING
Lethal voltages are present during some start up checks. Extreme caution must be used at all times.

 WARNING
Moving parts may be exposed during some startup checks. Extreme caution must be used at all times.

NOTE: Read and review this entire document before beginning any of the startup procedures.

DESIGN APPLICATION INFORMATION

This information will be available from the specifying engineer who selected the equipment. If the system is a VAV system the CFM will be the airflow when the remote VAV boxes are in the

full open position and the frequency drive is operating at 60 HZ. **Do not proceed with the equipment start-up without the design CFM information.**

Design Supply Air CFM: _____ Design Return Air CFM: _____

Design Outdoor Air CFM At Minimum Position: _____

Total External Static Pressure: _____

Supply Static Pressure: _____

Return Static Pressure: _____

Design Building Static Pressure: _____

Outside Air Dilution: Economizer Position Percentage: _____ CFM: _____

Supply Gas Pressure After Regulator W/o Heat Active _____ Inches _____

ADDITIONAL APPLICATION NOTES FROM SPECIFYING ENGINEER:

1034349 UCL E 0817

REFERENCE

General Inspection	Completed	See Notes
Unit inspected for shipping, storage, or rigging damage	<input type="checkbox"/>	<input type="checkbox"/>
Unit installed with proper clearances	<input type="checkbox"/>	<input type="checkbox"/>
Unit installed within slope limitations	<input type="checkbox"/>	<input type="checkbox"/>
Refrigeration system checked for gross leaks (presence of oil)	<input type="checkbox"/>	<input type="checkbox"/>
Terminal screws and wiring connections checked for tightness	<input type="checkbox"/>	<input type="checkbox"/>
Filters installed correctly and clean	<input type="checkbox"/>	<input type="checkbox"/>
Economizer hoods installed in operating position	<input type="checkbox"/>	<input type="checkbox"/>
Condensate drain trapped properly, refer to Installation Manual	<input type="checkbox"/>	<input type="checkbox"/>
Economizer damper linkage tight	<input type="checkbox"/>	<input type="checkbox"/>
Gas Heat vent hood installed	<input type="checkbox"/>	<input type="checkbox"/>
All field wiring (power and control) complete	<input type="checkbox"/>	<input type="checkbox"/>

Air Moving Inspection	Completed	See Notes
Alignment of drive components	<input type="checkbox"/>	<input type="checkbox"/>
Belt tension adjusted properly	<input type="checkbox"/>	<input type="checkbox"/>
Blower pulleys tight on shaft, bearing set screws tight, wheel tight to shaft	<input type="checkbox"/>	<input type="checkbox"/>
Pressure switch or transducer tubing installed properly	<input type="checkbox"/>	<input type="checkbox"/>

Exhaust Inspection Powered <input type="checkbox"/> Barometric Relief <input type="checkbox"/>	Completed	See Notes
Check hub for tightness	<input type="checkbox"/>	<input type="checkbox"/>
Check fan blade for clearance	<input type="checkbox"/>	<input type="checkbox"/>
Check for proper rotation	<input type="checkbox"/>	<input type="checkbox"/>
Check for proper mounting (screen faces towards unit)	<input type="checkbox"/>	<input type="checkbox"/>
Prove operation by increasing minimum setting on economizer	<input type="checkbox"/>	<input type="checkbox"/>

Economizer Inspection Standard <input type="checkbox"/> BAS <input type="checkbox"/>	Completed	See Notes
CO ₂ sensor installed Yes <input type="checkbox"/> No <input type="checkbox"/>	<input type="checkbox"/>	<input type="checkbox"/>
Check economizer setting (Reference Smart Equipment™ Control Board LCD menu location)	<input type="checkbox"/>	<input type="checkbox"/>
Prove economizer open/close through Smart Equipment™ Board Setting	<input type="checkbox"/>	<input type="checkbox"/>

Reheat Mode Normal <input type="checkbox"/> or Alternate <input type="checkbox"/> Not Applicable <input type="checkbox"/>
Humidity Sensor (2SH0401) _____

Operating Measurements - Air Flow

Fan operates with proper rotation (All VFD equipped units with the optional Manual Bypass must be phased for correct blower rotation with the Bypass switch set in the LINE position)		ID Fans <input type="checkbox"/>	Exh. Fans <input type="checkbox"/>	Cond. Fans <input type="checkbox"/>
Pressure drop across dry evaporator coil (At maximum design CFM) ¹				IWC
External Static Pressure				IWC
Return Static Pressure				IWC
Supply Static Pressure				IWC
Supply Air CFM Using Dry Coil Chart				CFM
Final Adjusted Supply Air CFM ²				CFM

- Consult the proper airflow to pressure drop table to obtain the actual airflow at the measured pressure differential.
- Was a motor pulley adjustment or change required to obtain the correct airflow?
Was it necessary to increase or decrease the airflow to meet the design conditions?
If the motor pulley size was changed, measure the outside diameters of the motor and blower pulleys and record those diameters here;

Blower Motor HP _____ FLA _____ RPM _____

Pulley Pitch Diameter _____ Turns Out _____ Final Turns Out _____

Blower Pulley Pitch Diameter _____ Fixed Sheave _____

ELECTRICAL DATA

T1 T2 _____ Volts T2 T3 _____ Volts
Control Voltage _____ Volts T1 T3 _____ Volts

Device	Nameplate	Measured List All Three Amperages
Supply Fan Motor ^{1, 2}	AMPS	AMPS
Exhaust Motor (Dampers 100%)	AMPS	AMPS
Condenser Fan #1	AMPS	AMPS
Condenser Fan #2 (if equipped)	AMPS	AMPS
Condenser Fan #3 (if equipped)	AMPS	AMPS
Condenser Fan #4 (if equipped)	AMPS	AMPS
Compressor #1	AMPS	AMPS
Compressor #2 (if equipped)	AMPS	AMPS
Compressor #3 (if equipped)	AMPS	AMPS
Compressor #4 (if equipped)	AMPS	AMPS

- VAV units with heat section - simulate heat call to drive VAV boxes and VFD/IGV to maximum design airflow position.
- VAV units without heat section - VAV boxes must be set to maximum design airflow position.

1034349 UCL E 0817

OPERATING MEASUREMENTS - COOLING

Stage	Discharge Pressure	Discharge Temp.	Liquid Line Temp. ¹	Subcooling ²	Suction Pressure	Suction Temp.	Superheat
First	#	°	°	°	#	°	°
Second (if equipped)	#	°	°	°	#	°	°
Third (if equipped)	#	°	°	°	#	°	°
Fourth (if equipped)	#	°	°	°	#	°	°
Reheat 1st Stage	#	°	°	°	#	°	°

1. Liquid temperature should be taken before filter/drier.

2. Subtract 10 psi from discharge pressure for estimated liquid line pressure

Outside air temperature _____ °F db _____ °F wb _____ %RH
 Return Air Temperature _____ °F db _____ °F wb _____ %RH
 Mixed Air Temperature _____ °F db _____ °F wb _____ %RH
 Supply Air Temperature _____ °F db _____ °F wb _____ %RH

REFRIGERANT SAFETIES

Action	Completed	See Notes
Prove Compressor Rotation (3 phase only) by gauge pressure	<input type="checkbox"/>	<input type="checkbox"/>
Prove High Pressure Safety, All Systems	<input type="checkbox"/>	<input type="checkbox"/>
Prove Low Pressure Safety, All Systems	<input type="checkbox"/>	<input type="checkbox"/>

OPERATING MEASUREMENTS - GAS HEATINGFuel Type: Natural Gas LP Gas

Action	Completed	See Notes
Check for gas leaks	<input type="checkbox"/>	<input type="checkbox"/>
Prove Ventor Motor Operation	<input type="checkbox"/>	<input type="checkbox"/>
Prove Primary Safety Operation	<input type="checkbox"/>	<input type="checkbox"/>
Prove Auxiliary Safety Operation	<input type="checkbox"/>	<input type="checkbox"/>
Prove Rollout Switch Operation	<input type="checkbox"/>	<input type="checkbox"/>
Prove Smoke Detector Operation	<input type="checkbox"/>	<input type="checkbox"/>
Manifold Pressure	Stage 1	IWC <input type="checkbox"/>
	Stage 2 (If Equipped)	IWC <input type="checkbox"/>
	Stage 3 (If Equipped)	IWC <input type="checkbox"/>
Supply gas pressure at full fire	IWC	<input type="checkbox"/>
Check temperature rise ¹	<input type="checkbox"/> measured at full fire	°F <input type="checkbox"/>

1. Input X Eff. (BTU output)
 1.08 X Temp. Rise

OPERATIONAL MEASUREMENTS - STAGING CONTROLS

Verify Proper Operation of Heating/Cooling Staging Controls	
Create a cooling demand at the Thermostat, BAS System or Smart Equipment™ Verify that cooling/economizer stages are energized.	<input type="checkbox"/>
Create a heating demand at the Thermostat, BAS System or Smart Equipment™ Verify that heating stages are energized.	<input type="checkbox"/>
Verify Proper Operation of the Variable Frequency Drive (If Required)	
Verify that motor speed modulates with duct pressure change.	<input type="checkbox"/>

FINAL - INSPECTION

Verify that all operational control set points have been set to desired value Scroll through all setpoints and change as may be necessary to suit the occupant requirements.	<input type="checkbox"/>
Verify that all option parameters are correct Scroll through all option parameters and ensure that all installed options are enabled in the software and all others are disabled in the software. (Factory software settings should match the installed options)	<input type="checkbox"/>
Verify that all access panels have been closed and secured	<input type="checkbox"/>
Save a backup file from the unit control board onto a USB flash drive.	<input type="checkbox"/>

OBSERVED PRODUCT DEFICIENCIES & CONCERNS:

R-410A QUICK REFERENCE GUIDE

Refer to Installation Instructions for specific installation requirements.

- R-410A Refrigerant operates at 50 - 70 percent higher pressures than R-22. Be sure that servicing equipment and replacement components are designed to operate with R-410A.
- R-410A Refrigerant cylinders are rose colored.
- Recovery cylinder service pressure rating must be 400 psig, DOT 4BA400, or DOT BW400.
- Recovery equipment must be rated for R-410A.
- **Do Not** use R-410A service equipment on R-22 systems. All hoses, gages, recovery cylinders, charging cylinders and recovery equipment must be dedicated for use on R-410A systems only.
- Manifold sets must be at least 700 psig high side, and 180 psig low side, with 550 psig retard.
- All hoses must have a service pressure rating of 800 psig.
- Leak detectors must be designed to detect HFC refrigerants.
- Systems must be charged with liquid refrigerant. Use a commercial type metering device in the manifold hose.
- R-410A can only be used with POE type oils.
- POE type oils rapidly absorb moisture from the atmosphere.
- Vacuum pumps will **not** remove moisture from POE type oils.
- **Do not** use liquid line driers with a rated working pressure rating less than 600 psig.
- **Do not** install suction line driers in the liquid line.
- A liquid line drier is required on every unit.
- **Do not** use a R-22 TXV. If a TXV is to be used, it must be a R-410A TXV.
- Never open system to atmosphere when under a vacuum.
- If system must be opened for service, evacuate system then break the vacuum with dry nitrogen and replace all filter driers.

FIGURE 63 - R-410A QUICK REFERENCE GUIDE